



Chipsmall Limited consists of a professional team with an average of over 10 year of expertise in the distribution of electronic components. Based in Hongkong, we have already established firm and mutual-benefit business relationships with customers from,Europe,America and south Asia,supplying obsolete and hard-to-find components to meet their specific needs.

With the principle of "Quality Parts,Customers Priority,Honest Operation,and Considerate Service",our business mainly focus on the distribution of electronic components. Line cards we deal with include Microchip,ALPS,ROHM,Xilinx,Pulse,ON,Everlight and Freescale. Main products comprise IC,Modules,Potentiometer,IC Socket,Relay,Connector.Our parts cover such applications as commercial,industrial, and automotives areas.

We are looking forward to setting up business relationship with you and hope to provide you with the best service and solution. Let us make a better world for our industry!



## Contact us

Tel: +86-755-8981 8866 Fax: +86-755-8427 6832

Email & Skype: info@chipsmall.com Web: www.chipsmall.com

Address: A1208, Overseas Decoration Building, #122 Zhenhua RD., Futian, Shenzhen, China



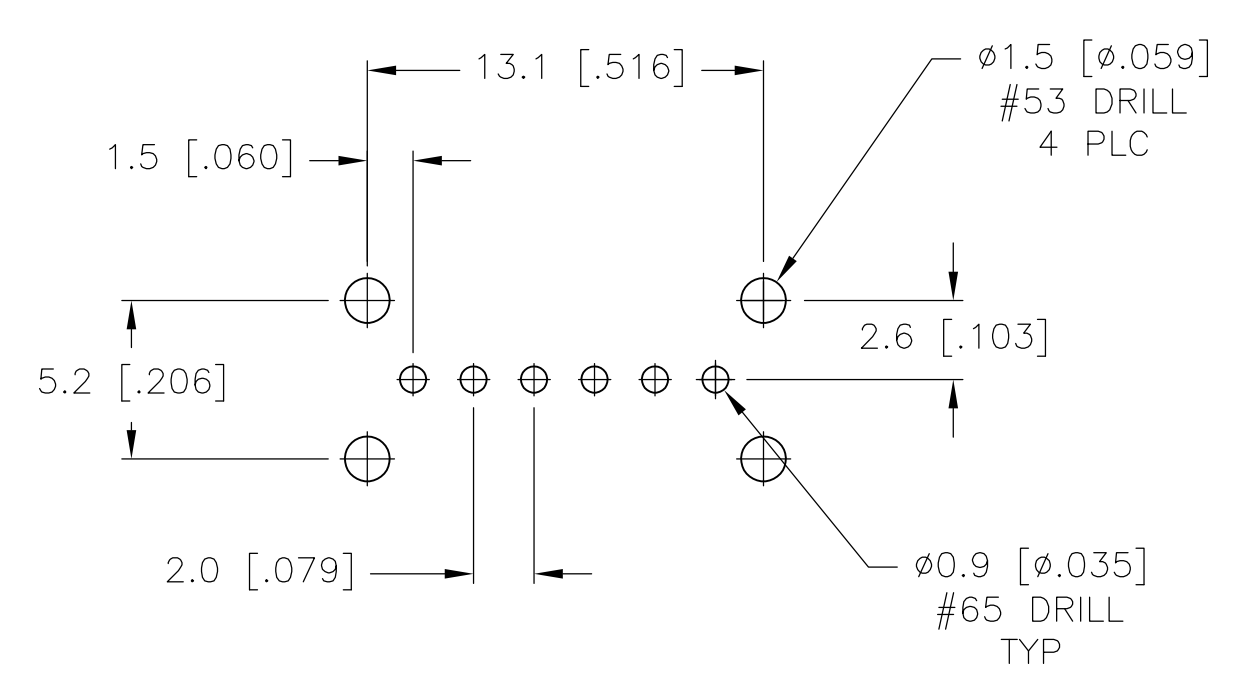
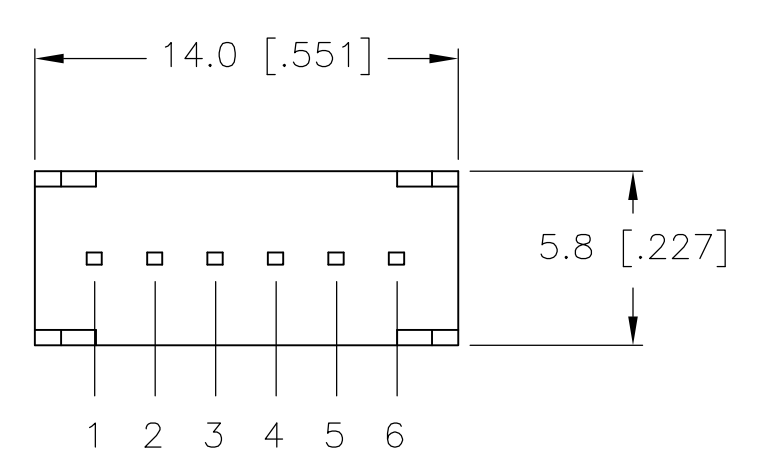
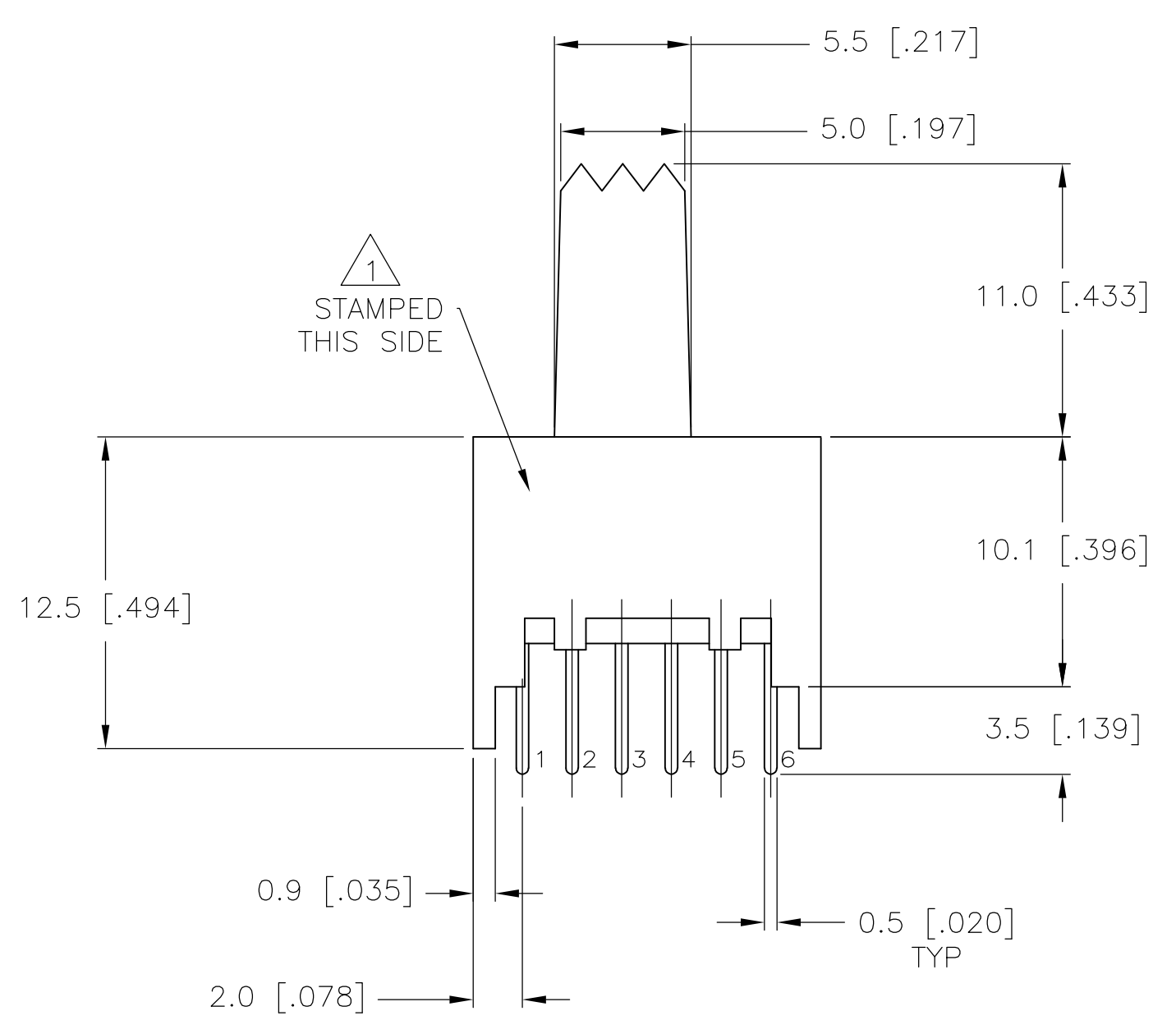
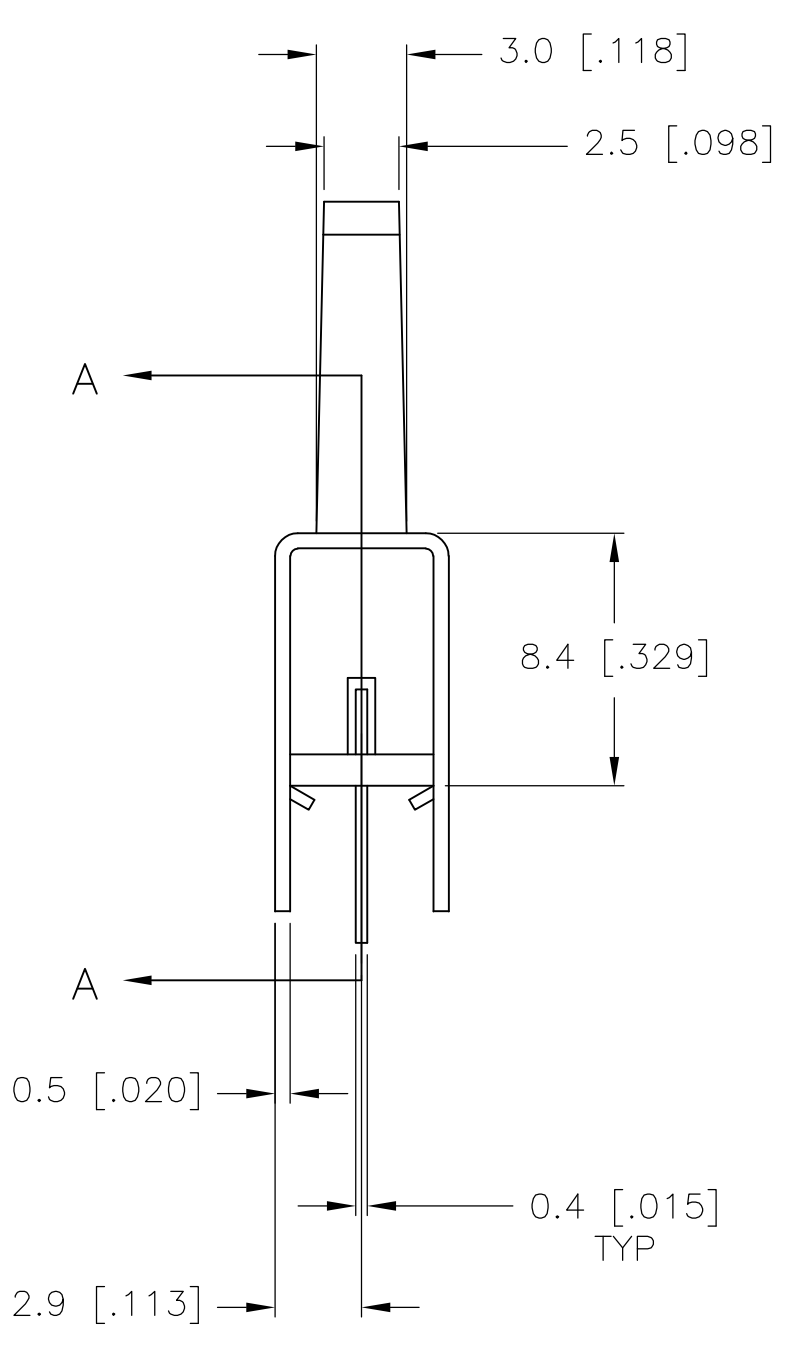
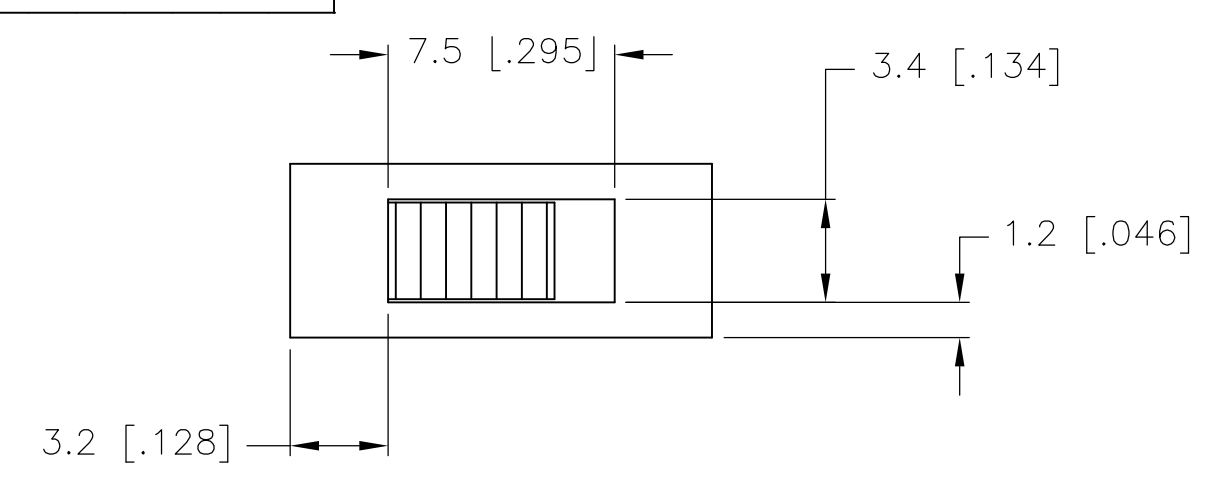

RECOMMENDED BOARD LAYOUT

**SPECIFICATIONS**  
MAKE-BEFORE-BREAK

**MATERIALS:**  
 ACTUATOR- POM, UL94HB BLACK  
 TERMINAL BOARD- PHENOLIC LAMINATED SHEET, UL94HB, NATURAL  
 FRAME- STEEL, NICKEL PLATE  
 TERMINAL/FIXED CONTACT- COPPER ALLOY, GOLD OR SILVER OVER NICKEL PLATE  
 MOVING CONTACT- COPPER ALLOY, GOLD OR SILVER OVER NICKEL PLATE  
 DETENT BALL- STEEL  
 COIL SPRING- GALVANIZED SPRING WIRE  
 SEAL- EPOXY

**ELECTRICAL:**  
 CONTACT RATING- .4VA@20VDC OR PEAK AC (GOLD); 300mA@125V AC (SILVER)  
 INITIAL CONTACT RESISTANCE- 30 milliohm max.  
 FINAL CONTACT RESISTANCE- 100 milliohm max. (AFTER TEST)  
 INSULATION RESISTANCE- 1,000 Megohms min.  
 DIELECTRIC STRENGTH- 500V RMS@SEA LEVEL  
 LIFE EXPECTANCY- 15,000 CYCLES MIN.

**MECHANICAL:**  
 ACTUATION FORCE- 600+/-300 GRAMS  
 TRAVEL- 2.0 +/- .50 (.079 +/- .020)

**ENVIRONMENTAL:**  
 OPERATING TEMPERATURE- -20 TO +85 DEGREES C  
 STORAGE TEMPERATURE- -40 TO +100 DEGREES C  
 RESISTANCE TO SOLDER HEAT PER 109-202, CONDITION B  
 SOLDERABILITY PER EIA-364-52, CLASS 2, CATEGORY 1, 95% MIN COVERAGE

**NOTES:**

- 1 COUNTRY OF ORIGIN AND TE CONNECTIVITY LOGO LOCATED APPROXIMATELY AS SHOWN
2. ALL MATERIALS AND FINISHES SHALL COMPLY WITH EU DIRECTIVE 2002/95/EC OF 27JAN2003 (ROHS)
- 3 ANTI SOLDER WICK SEAL AT TERMINAL TO BOARD INTERFACE
4. ALL PERFORMANCE TESTING WAS DONE IN ACCORDANCE TO TE CONNECTIVITY SPECIFICATION 102-2469

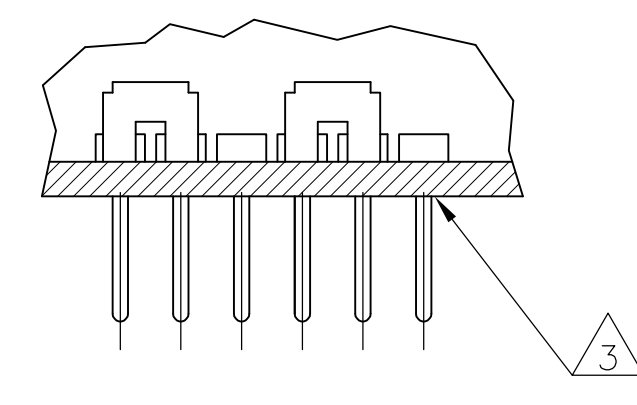

SECTION A-A

1825263-2	MSS2250G04	GOLD	2 TO 1 5 TO 4	2 TO 3 5 TO 6
1825263-1	MSS225004	SILVER	2 TO 1 5 TO 4	2 TO 3 5 TO 6
PART NO.	T&B PART NO.	PLATING		

TERMINALS CONNECTED WHEN SLIDE IS IN POSITION SHOWN.

THIS DRAWING IS A CONTROLLED DOCUMENT.		DIN R BROWN 21DEC05	TE Connectivity	
DIMENSIONS: mm		CHK M SARVER 21DEC05		
TOLERANCES UNLESS OTHERWISE SPECIFIED:		APVD M SARVER 21DEC05	NAME SLIDE SWITCH, MSS 2250 SERIES, DP-DT, VERTICAL	
0 PLC ± -		PRODUCT SPEC	APPLICATION SPEC	
1 PLC ± 0.3 [.012]		SIZE		RESTRICTED TO
2 PLC ± -		A1 00779C=1825263		
3 PLC ± -		WEIGHT		
4 PLC ± -		CUSTOMER DRAWING		
ANGLES ± ±		SCALE 4:1		SHEET 1 OF 1
FINISH		REV A2		