



Chipsmall Limited consists of a professional team with an average of over 10 year of expertise in the distribution of electronic components. Based in Hongkong, we have already established firm and mutual-benefit business relationships with customers from,Europe,America and south Asia,supplying obsolete and hard-to-find components to meet their specific needs.

With the principle of “Quality Parts,Customers Priority,Honest Operation,and Considerate Service”,our business mainly focus on the distribution of electronic components. Line cards we deal with include Microchip,ALPS,ROHM,Xilinx,Pulse,ON,Everlight and Freescale. Main products comprise IC,Modules,Potentiometer,IC Socket,Relay,Connector.Our parts cover such applications as commercial,industrial, and automotives areas.

We are looking forward to setting up business relationship with you and hope to provide you with the best service and solution. Let us make a better world for our industry!



## Contact us

Tel: +86-755-8981 8866 Fax: +86-755-8427 6832

Email & Skype: info@chipsmall.com Web: www.chipsmall.com

Address: A1208, Overseas Decoration Building, #122 Zhenhua RD., Futian, Shenzhen, China



LOC		DIST		REVISIONS			
AD	00	REV	DATE	BY	APPV		
A1		REVISED PER ECO-10-008611	24APR10	HMR	NE		

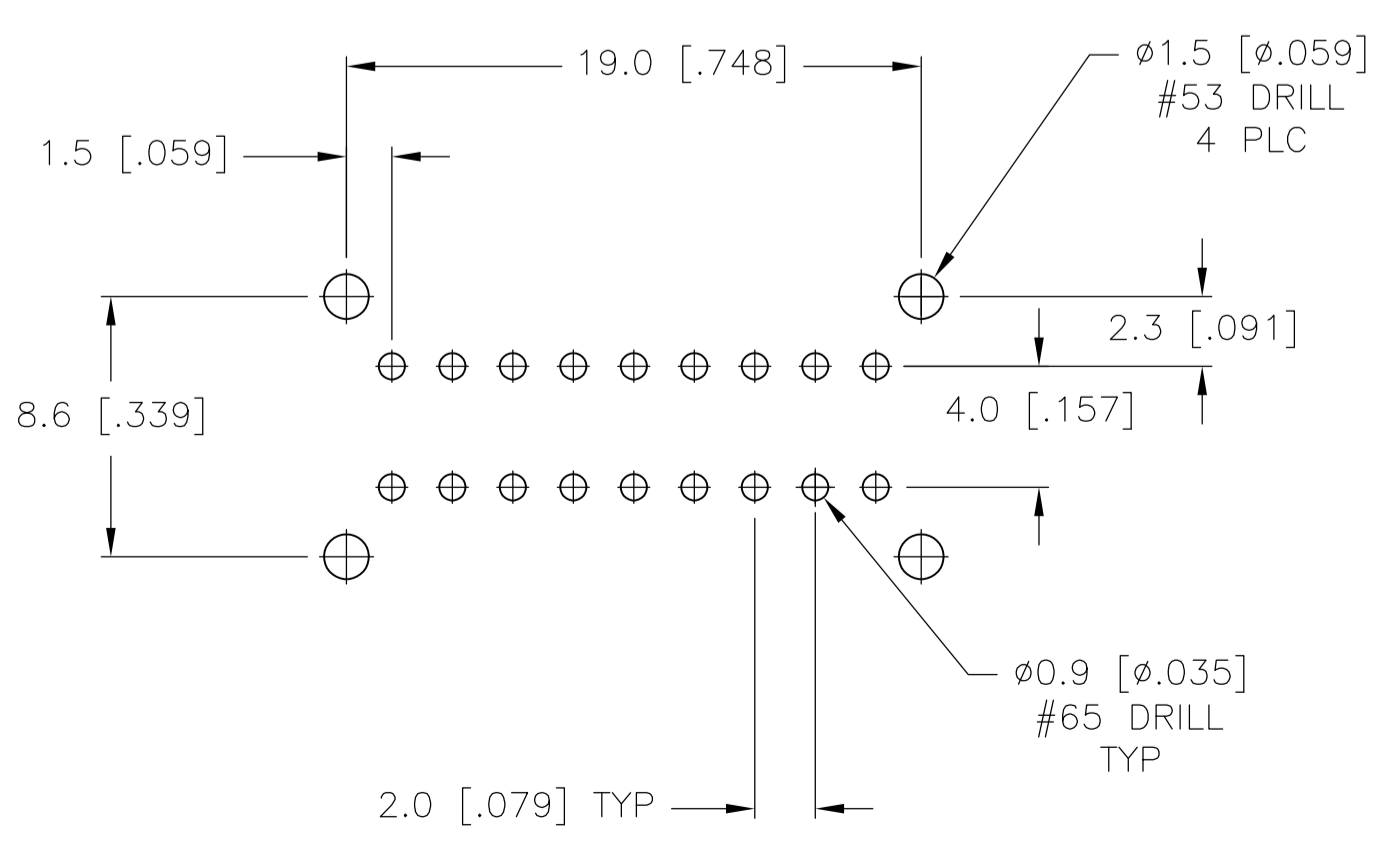
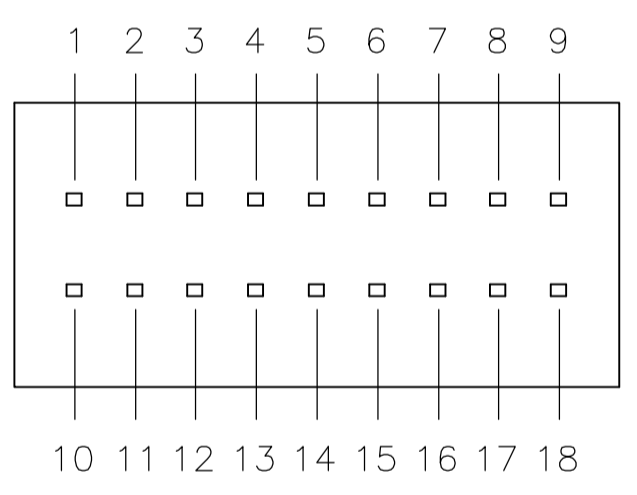
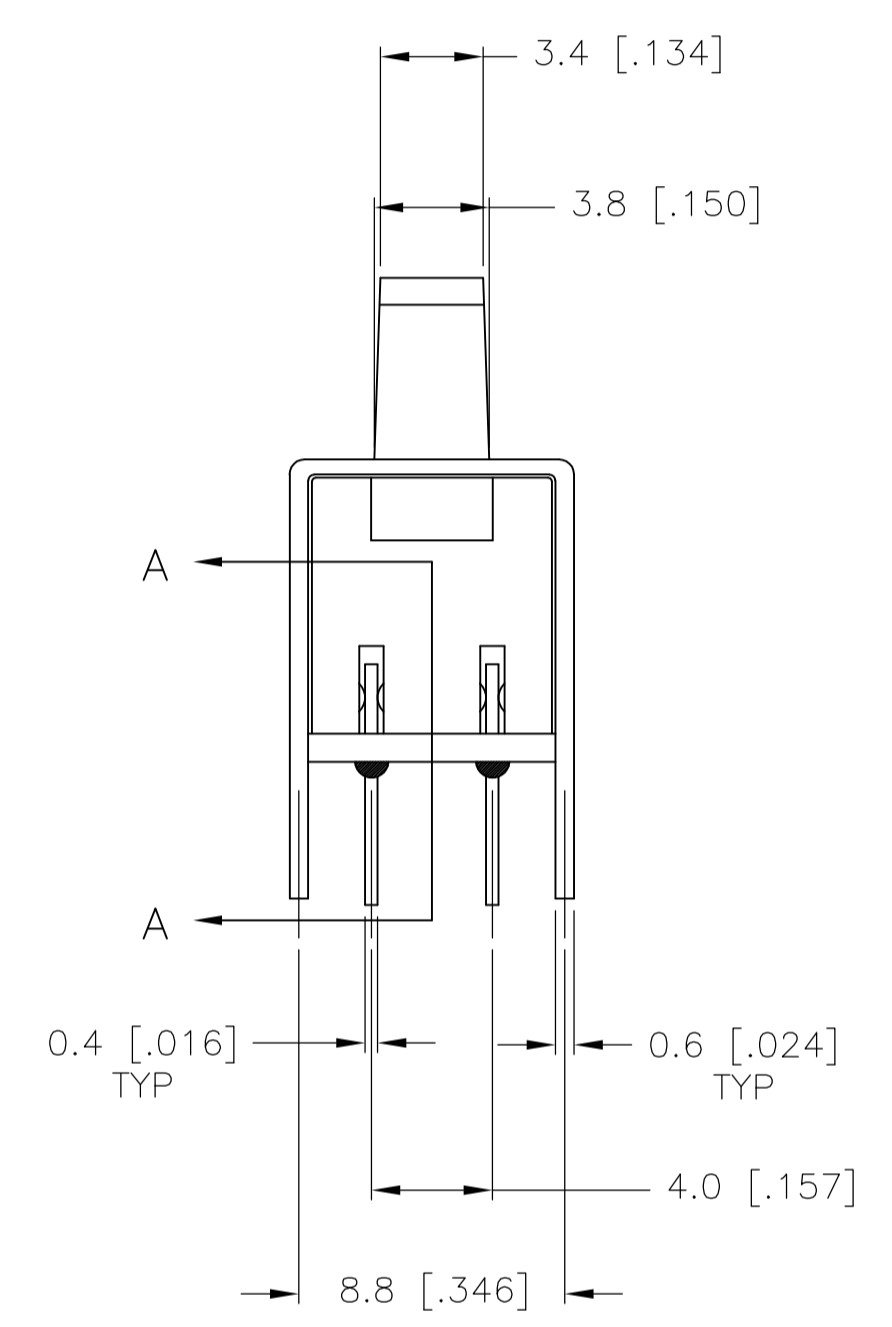
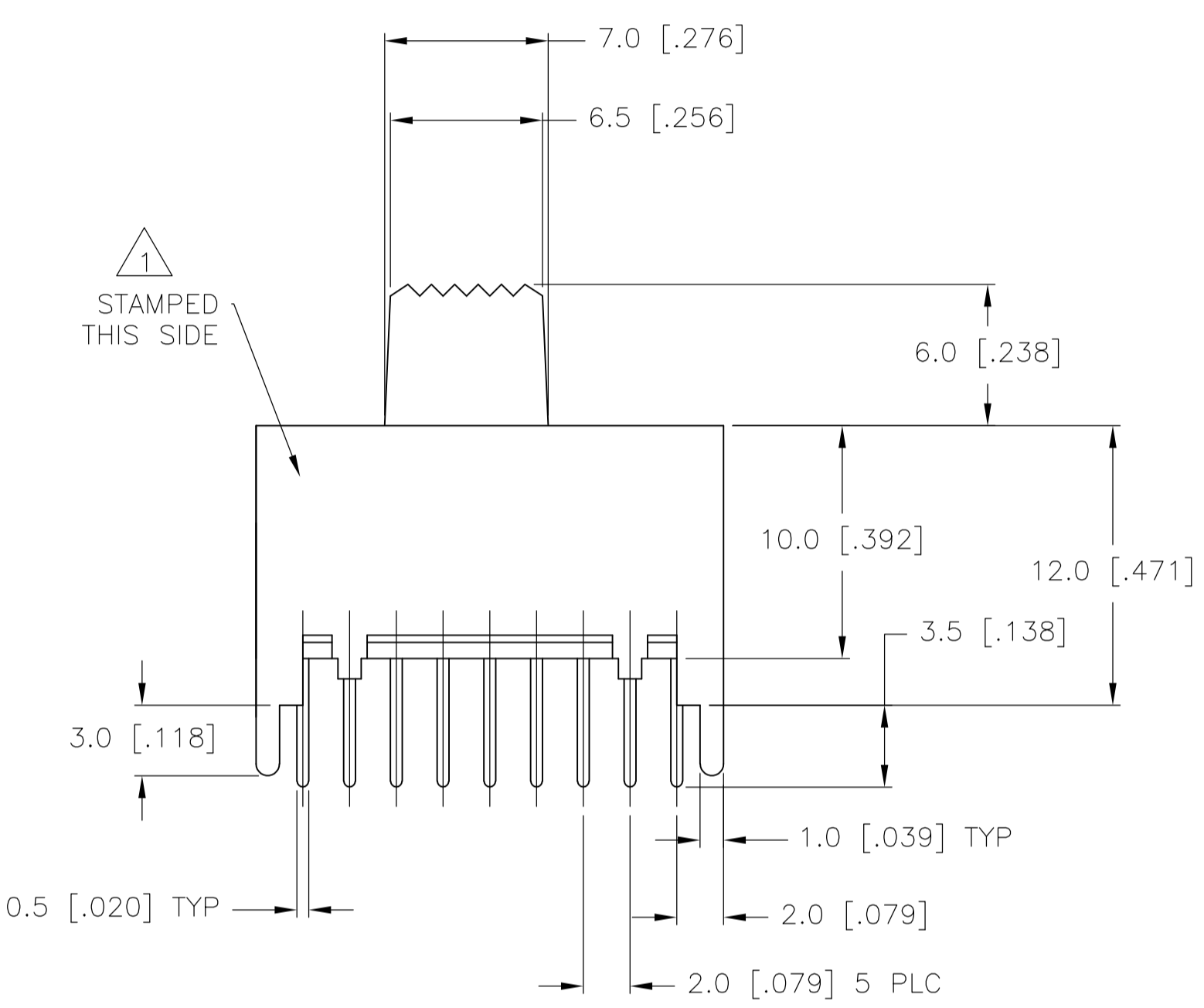
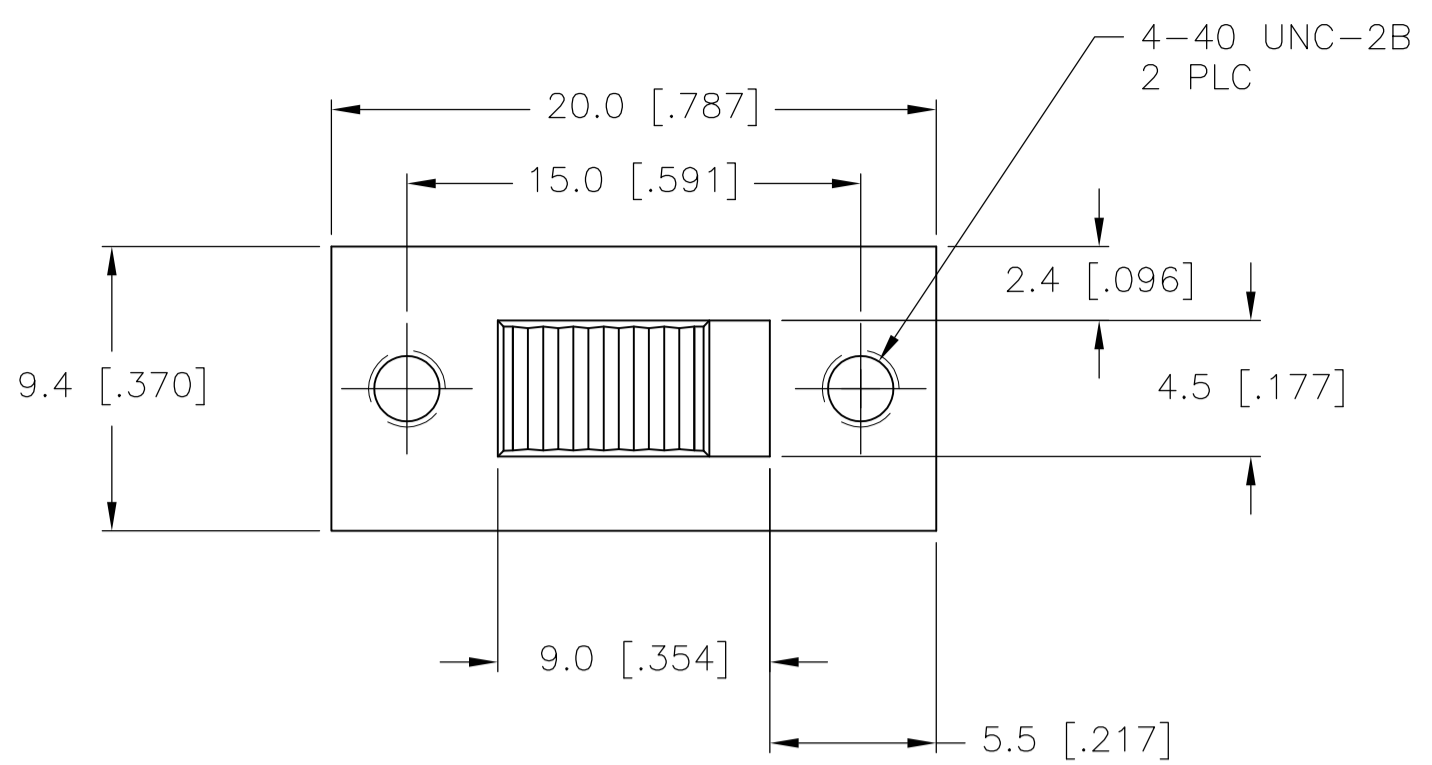

RECOMMENDED BOARD LAYOUT

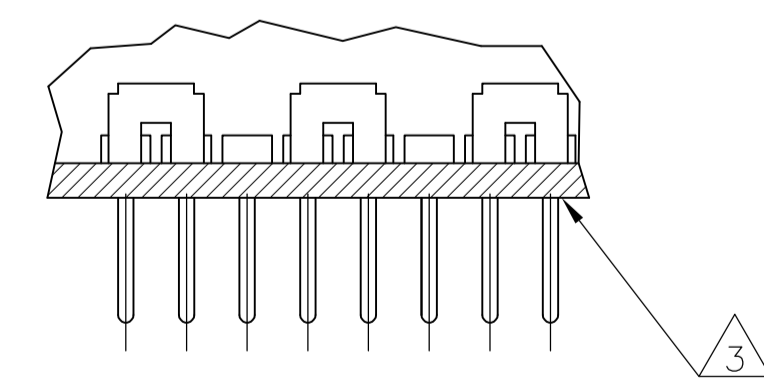

SECTION A-A

SPECIFICATIONS  
 MAKE-BEFORE-BREAK

MATERIALS:  
 ACTUATOR- POM, UL94HB BLACK  
 TERMINAL BOARD- PHENOLIC LAMINATED SHEET, UL94HB, NATURAL  
 FRAME- STEEL, NICKEL PLATE  
 TERMINAL/FIXED CONTACT- COPPER ALLOY, GOLD OR SILVER OVER NICKEL PLATE  
 MOVING CONTACT- COPPER ALLOY, GOLD OR SILVER OVER NICKEL PLATE  
 DETENT BALL- STEEL  
 COIL SPRING- GALVANIZED SPRING WIRE  
 SEAL- EPOXY

ELECTRICAL:  
 CONTACT RATING- .4VA@20VDC OR PEAK AC (GOLD); 300mA@125V AC (SILVER)  
 INITIAL CONTACT RESISTANCE- 30 milliohm max.  
 FINAL CONTACT RESISTANCE- 100 milliohm max. (AFTER TEST)  
 INSULATION RESISTANCE- 1,000 Megohms min.  
 DIELECTRIC STRENGTH- 500V RMS@SEA LEVEL  
 LIFE EXPECTANCY- 15,000 CYCLES MIN.

MECHANICAL:  
 ACTUATION FORCE- 600+/-300 GRAMS  
 TRAVEL- 2.0 +/- .50 (.079 +/- .020)

ENVIRONMENTAL:  
 OPERATING TEMPERATURE- -20 TO +85 DEGREES C  
 STORAGE TEMPERATURE- -40 TO +100 DEGREES C  
 RESISTANCE TO SOLDER HEAT PER 109-202, CONDITION B  
 SOLDERABILITY PER EIA-364-52, CLASS 2, CATEGORY 1, 95% MIN COVERAGE

NOTES:

- COUNTRY OF ORIGIN AND TE LOGO LOCATED APPROXIMATELY AS SHOWN
- ALL MATERIALS AND FINISHES SHALL COMPLY WITH EU DIRECTIVE 2002/95/EC OF 27JAN2003 (ROHS)
- ANTI SOLDER WICK SEAL AT TERMINAL TO BOARD INTERFACE
- ALL PERFORMANCE TESTING WAS DONE IN ACCORDANCE TO TYCO SPECIFICATION 102-2469

1825271-2	MSS6200G04	GOLD	2 - 1 11 - 10 5 - 4 14 - 13 8 - 7 17 - 16	2 - 3 11 - 12 5 - 6 14 - 15 8 - 9 17 - 18
1825271-1	MSS620004	SILVER	2 - 1 11 - 10 5 - 4 14 - 13 8 - 7 17 - 16	2 - 3 11 - 12 5 - 6 14 - 15 8 - 9 17 - 18
TYCO PART NO.	T&B PART NO.	PLATING		

THIS DRAWING IS A CONTROLLED DOCUMENT.		DIN R BROWN 21DEC05	Tyco Electronics Corporation Harrisburg, Pa 17105-3608	
DIMENSIONS: mm		CHK M SARVER 21DEC05	NAME SLIDE SWITCH, MSS 6200 SERIES, 6P-DT	
TOLERANCES UNLESS OTHERWISE SPECIFIED:		APPV M SARVER 21DEC05	PRODUCT SPEC	
0 PLC ± -		APPLICATION SPEC		
1 PLC ± 0.3 [.012]		SIZE CAGE CODE DRAWING NO		
2 PLC ± -		RESTRICTED TO		
3 PLC ± -		WEIGHT		
4 PLC ± -		A1 00779C=1825271		
ANGLES ± -		CUSTOMER DRAWING		
MATERIAL		SCALE 4:1 SHEET 1 OF 1 REV A1		