



Chipsmall Limited consists of a professional team with an average of over 10 year of expertise in the distribution of electronic components. Based in Hongkong, we have already established firm and mutual-benefit business relationships with customers from,Europe,America and south Asia,supplying obsolete and hard-to-find components to meet their specific needs.

With the principle of “Quality Parts,Customers Priority,Honest Operation,and Considerate Service”,our business mainly focus on the distribution of electronic components. Line cards we deal with include Microchip,ALPS,ROHM,Xilinx,Pulse,ON,Everlight and Freescale. Main products comprise IC,Modules,Potentiometer,IC Socket,Relay,Connector.Our parts cover such applications as commercial,industrial, and automotives areas.

We are looking forward to setting up business relationship with you and hope to provide you with the best service and solution. Let us make a better world for our industry!



Contact us

Tel: +86-755-8981 8866 Fax: +86-755-8427 6832

Email & Skype: info@chipsmall.com Web: www.chipsmall.com

Address: A1208, Overseas Decoration Building, #122 Zhenhua RD., Futian, Shenzhen, China



THIS DRAWING IS UNPUBLISHED. RELEASED FOR PUBLICATION
 © COPYRIGHT - By - ALL RIGHTS RESERVED.

LOC	DIST	REVISIONS			
P	LTR	DESCRIPTION	DATE	DWN	APVD
AD	00	A1	REVISED PER ECO-11-005027	14MAR11	RK HMR

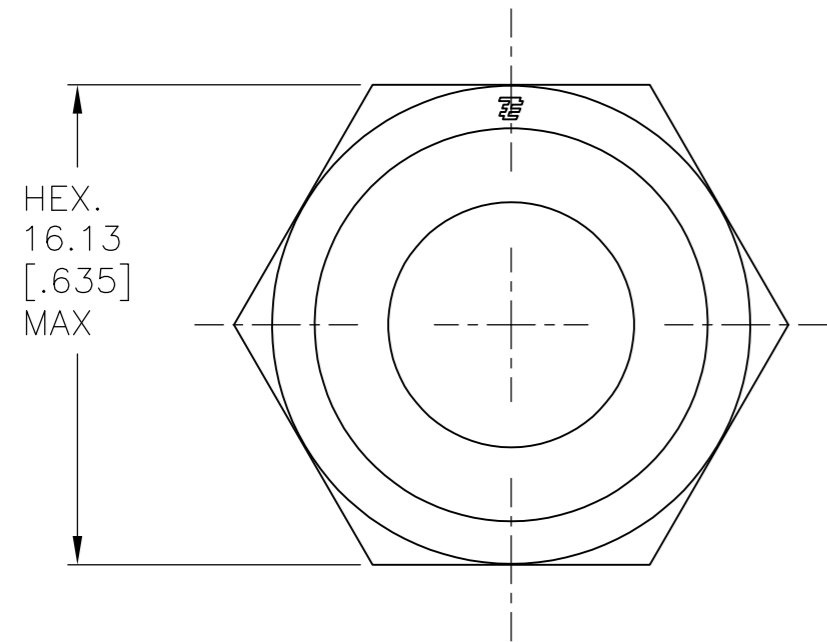

TE SYMBOL
 RAISED 0.25 [.010]

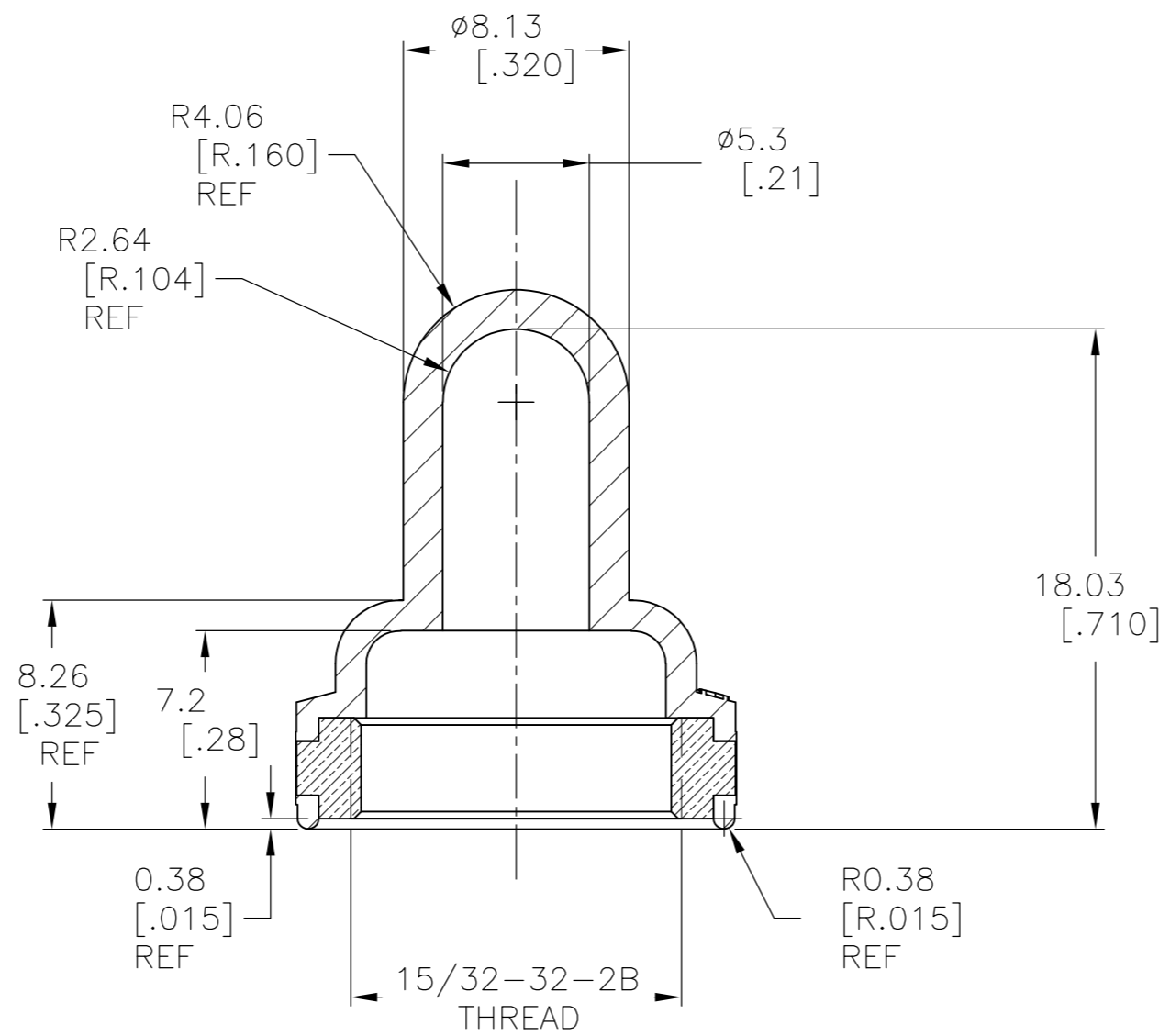
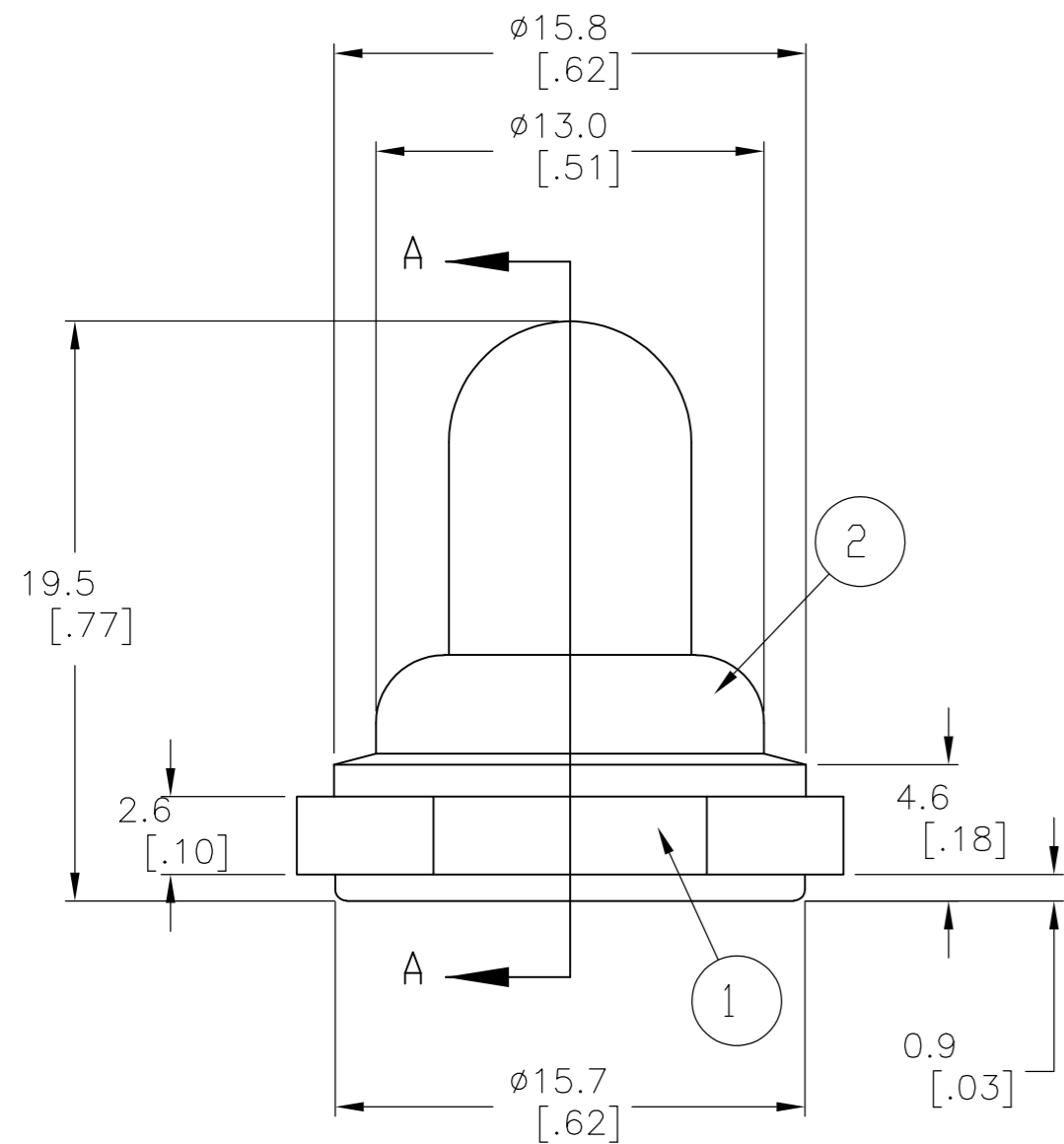
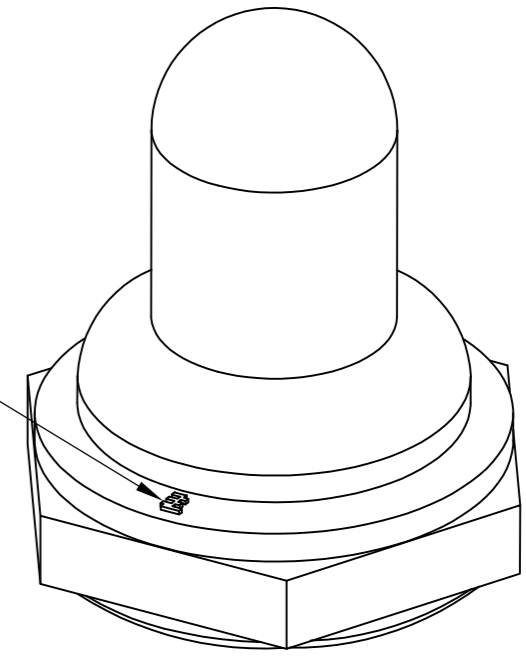

SECTION A-A

- SOME DIMENSIONS MAY VARY DUE TO DIFFERENT COMPOUND SHRINKAGE FACTOR.
- MINOR FLASH ACCEPTABLE ON INSERT THREAD.
- BLACK FINISH/NICKEL PLATING ON INSIDE THREADS REMOVED DUE TO MOLDING PROCESS PERMITTED.
- RUBBER TO METAL BOND MUST MEET OR EXCEED THE TEAR STRENGTH OF RUBBER.
- RUBBER OVERLAY PERMISSIBLE OVER HEX FLATS AS SHOWN IN THE DRAWING.
- COMPONENTS MUST COMPLY WITH THE EUROPEAN DIRECTIVE 2002/95/EC ON RESTRICTION OF THE USE OF CERTAIN HAZARDOUS SUBSTANCES IN ELECTRICAL AND ELECTRONIC EQUIPMENT (ROHS DIRECTIVE).

ALCO P/N	PART NUMBER	HEX NUT MATERIAL	RUBBER BOOT MATERIAL
B1532004	1825602-1	BRASS, BLACK OXIDE PER MIL-F-495	SILICONE, COLOR BLACK
B1532204	1825602-2	BRASS, NICKEL PLATE PER QQ-N-290	SILICONE, COLOR RED
B1532804	1825602-3	BRASS, NICKEL PLATE PER QQ-N-290	SILICONE, COLOR GRAY

NO.	DESCRIPTION	DRAWING NO.	MATERIAL
①	NUT 15/32-32 UNS-2B	HEX NUT 15/32-32	BRASS, FINISH AS PER ABOVE TABLE
②	RUBBER BOOT	RUBBER BOOT	SILICONE PER ZZ-R-765, CLASS 3A, GRADE 50 COLOR AS PER ABOVE TABLE

THIS DRAWING IS A CONTROLLED DOCUMENT.		DWN R BROWN 09JAN2008	TE Connectivity	
DIMENSIONS: mm [INCHES]		CHK M WILBOURN 09JAN2008		
TOLERANCES UNLESS OTHERWISE SPECIFIED:		APVD M WILBOURN 09JAN2008	NAME 15/32-32 TOGGLE SWITC H BOOT SEAL	
0 PLC ± - 1 PLC ± - 2 PLC ± 0.25[.010] 3 PLC ± 0.13[.005] 4 PLC ± - ANGLES ± 5°		PRODUCT SPEC	SIZE A2	
MATERIAL		APPLICATION SPEC	CAGE CODE 00779	DRAWING NO C=1825602
FINISH		WEIGHT	SCALE 4:1	SHEET 1 OF 1
		CUSTOMER DRAWING	REV A1	RESTRICTED TO