



Chipsmall Limited consists of a professional team with an average of over 10 year of expertise in the distribution of electronic components. Based in Hongkong, we have already established firm and mutual-benefit business relationships with customers from,Europe,America and south Asia,supplying obsolete and hard-to-find components to meet their specific needs.

With the principle of “Quality Parts,Customers Priority,Honest Operation,and Considerate Service”,our business mainly focus on the distribution of electronic components. Line cards we deal with include Microchip,ALPS,ROHM,Xilinx,Pulse,ON,Everlight and Freescale. Main products comprise IC,Modules,Potentiometer,IC Socket,Relay,Connector.Our parts cover such applications as commercial,industrial, and automotives areas.

We are looking forward to setting up business relationship with you and hope to provide you with the best service and solution. Let us make a better world for our industry!



## Contact us

Tel: +86-755-8981 8866 Fax: +86-755-8427 6832

Email & Skype: info@chipsmall.com Web: www.chipsmall.com

Address: A1208, Overseas Decoration Building, #122 Zhenhua RD., Futian, Shenzhen, China



THIS DRAWING AND THE SUBJECT MATTER SHOWN THEREON ARE CONFIDENTIAL AND THE PROPERTY OF BEL/STEWART/TRP CONNECTOR AND SHALL NOT BE REPRODUCED, COPIED, OR USED IN ANY MANNER WITHOUT THE WRITTEN CONSENT OF TRP CONNECTOR.

PRODUCT MAY BE PROTECTED BY ONE OR MORE OF THE FOLLOWING US PATENTS:  
 5736910 5939955 6425781 6428361 6554638 6840817 7123117  
 7429195 7717749 7808751 6217391 6149050 7924130

REVISIONS				
#	LT#	DESCRIPTION	DATE	OWN APVD
7		EC-1411035 COMPANY LOGO CHANGE	26DEC2014	DP TY

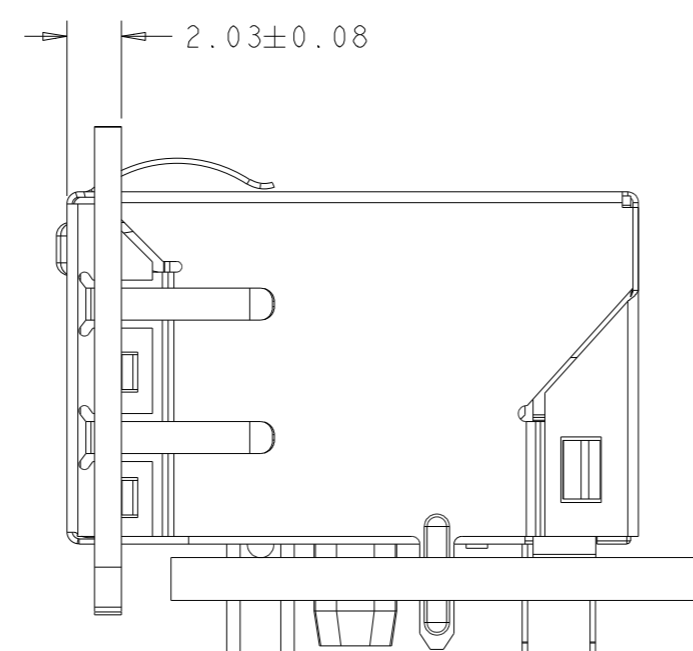
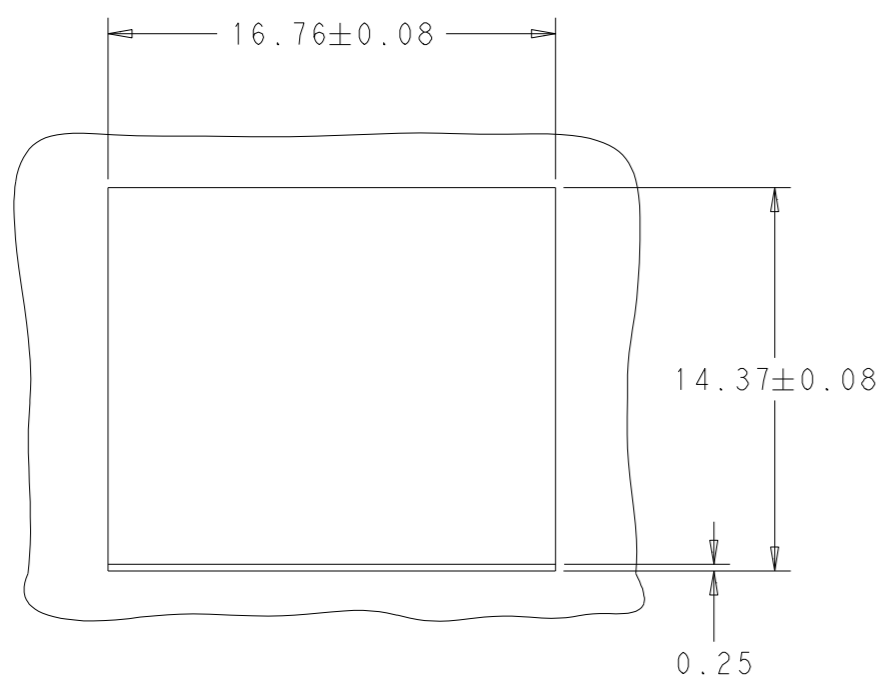
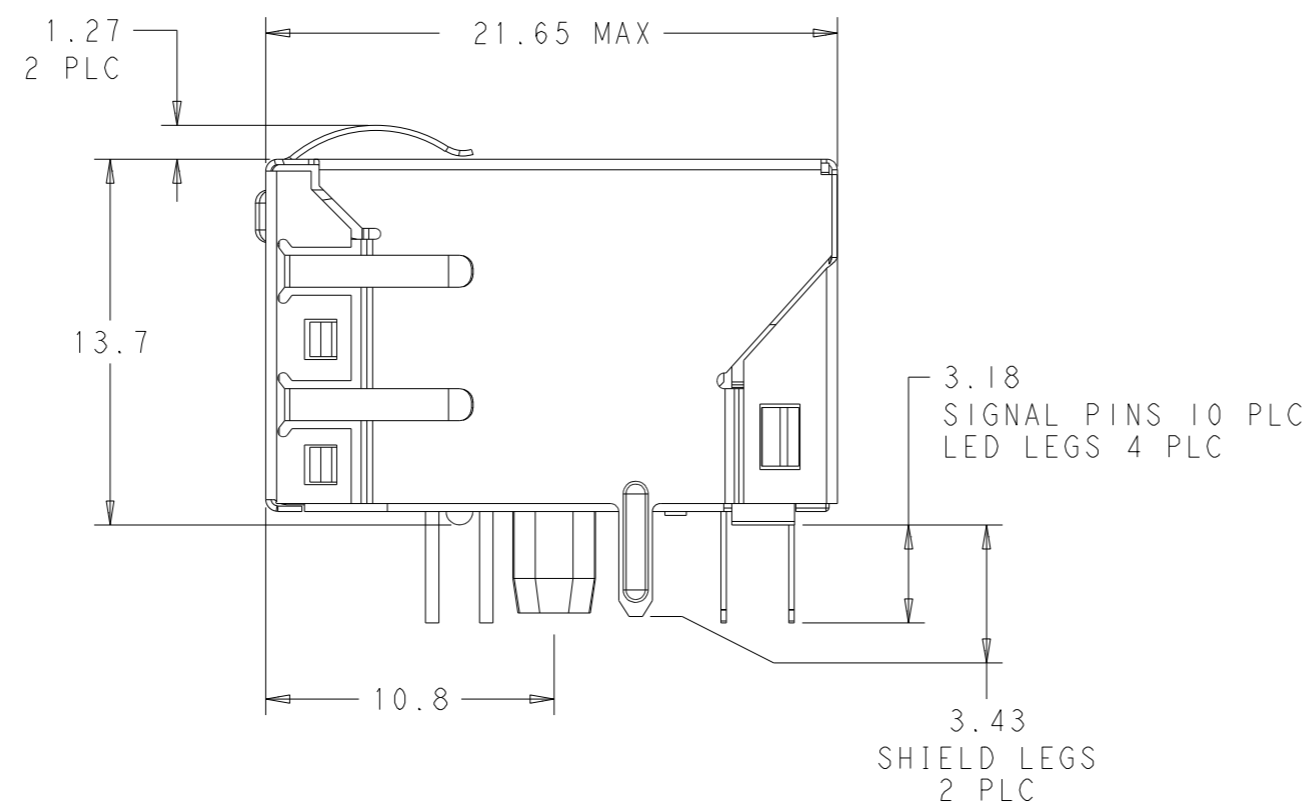
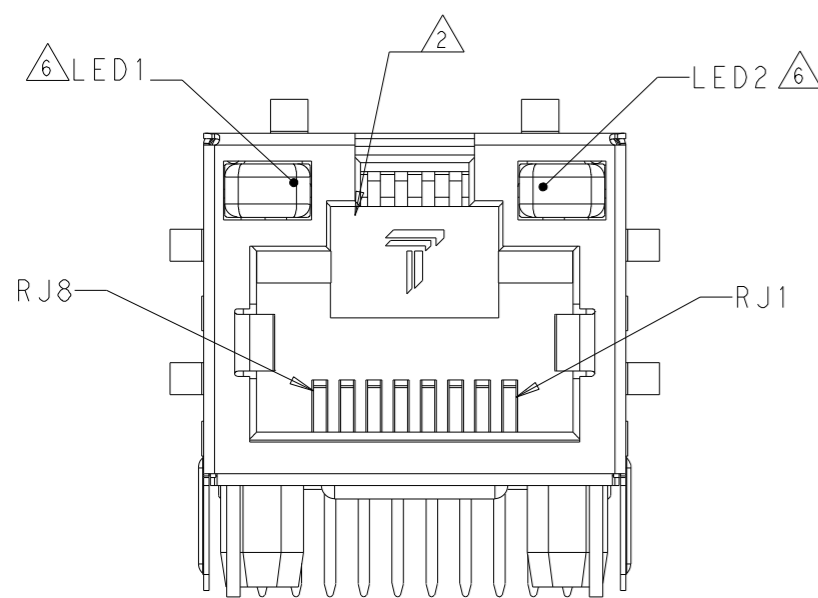
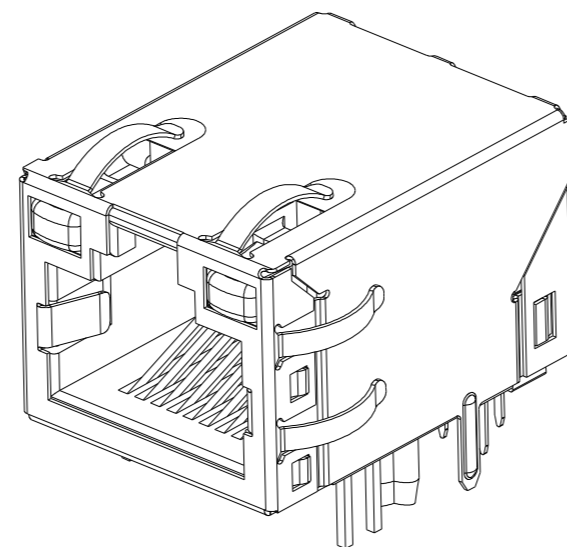
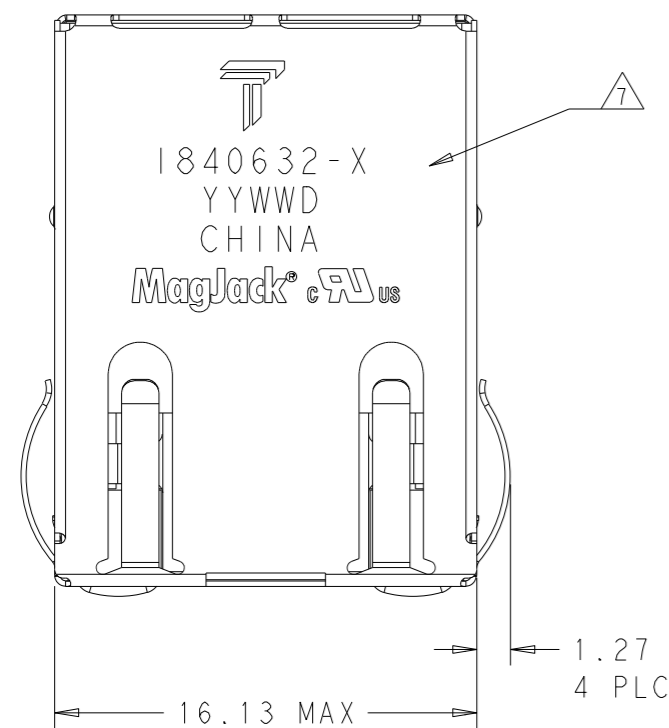

SUGGESTED CUT PANEL AND PCB

1. MATERIALS

- HOUSING: THERMOPLASTIC, FLAMMABILITY RATING UL 94V-0.
- SHIELD: BRASS 0.20mm THICK, PREPLATED WITH 0.76um MIN SEMI-BRIGHT NICKEL. SOLDER TABS POST DIPPED WITH 2.54um MIN SAC SOLDER.
- CONTACTS: PHOSPHOR BRONZE 0.46mm X 0.30mm. PHOSPHOR BRONZE, 1.27um MIN NICKEL UNDERPLATE, WITH 1.27um MIN GOLD PLATING AT MATING INTERFACE AND 2.54um MIN MATTE TIN ON SOLDER TAILS, OR 1.27um MIN NICKEL UNDERPLATE, WITH 0.05um GOLD PLATING OVER 0.76um MIN PALLADIUM NICKEL PLATING AT MATING INTERFACE AND 2.54um MIN MATTE TIN ON SOLDER TAILS.
- SOLDER TAILS: 0.25mm THICK, PHOSPHOR BRONZE, 1.27um MIN OVERALL NICKEL UNDERPLATE, 3um TIN PLATE
- LIGHT EMITTING DIODE (LED): DIFFUSED EPOXY LENS, 0.5mm X 0.5mm CARBON STEEL WIREFRAME LEADS PREPLATED WITH 2.03um MIN. SILVER PLATE OVER 1.02um MIN. NICKEL OVER 1.02um MIN. COPPER UNDERPLATE; LEADS POST-PLATED WITH 2.54um MIN. MATTE TIN AND/OR SAC SOLDER DIP OR PURE TIN SOLDER DIP

△ RJ45 JACK CAVITY CONFORMS TO FCC RULES AND REGULATIONS PART 68 SUB PART F.

△ 3. MAGNETICS

- APPLICATION: 10/100/1000 BASE-T
- IMPEDANCE: 100 OHMS
- TURNS RATIO (CHIP:CABLE): 1:1 ALL FOUR PAIRS
- OPEN CIRCUIT INDUCTANCE (OCL): 350uH MIN. @100kHz, 0.1VRMS, 8mADC BIAS FROM 0°C TO 70°C, ALL FOUR PAIRS
- ALL FOUR PAIRS BI-DIRECTIONAL
- PERFORMANCE @ 25°C:  
 INSERTION LOSS (IL): 1.1dB MAX. FROM 0.5MHz TO 100MHz  
 RETURN LOSS (RL): 18dB MIN FROM 0.5MHz TO 40MHz  
 12-20LOG(f/80)dB MIN. FROM 40.1MHz TO 100MHz  
 CROSSTALK ATTENUATION: 35dB MIN. FROM 0.5MHz TO 40MHz  
 33-20LOG(f/50)dB MIN. FROM 40.1MHz TO 100MHz  
 COMMON MODE REJECTION RATIO (CMRR): 30dB MIN. FROM 0.5MHz TO 100MHz
- ISOLATION VOLTAGE: 2250VDC FOR 60 SECONDS WITH A RISE TIME OF 500 V/SEC

4. OPERATING TEMPERATURE: FROM 0°C TO +70°C.

△ 5. INDICATED MAGNETIC CONNECTIONS ARE SYMMETRICAL TO SUPPORT AUTO-MDI/MDIX.

△ 6. THE 250 OHM LED RESISTORS ARE OPTIONAL, PLEASE SEE CHART FOR PRESENCE OR ABSENCE OF RESISTORS.

- IF LEADS WITHOUT 250 OHM RESISTORS. LEADS ARE DRIVEN WITH CONSTANT CURRENT AT APPROX 20mA  
 LED COLOR: DOMINATE WAVELENGTH (λD): GREEN 568 nm TYP. AT IF = 20mA  
 FORWARD VOLTAGE (VF): GREEN 2.2V TYP. @ IF = 20mA  
 DOMINATE WAVELENGTH (λD): YELLOW 588 nm TYP. AT IF = 20mA  
 FORWARD VOLTAGE (VF): YELLOW 2.1V TYP. @ IF = 20mA
- IF LEADS WITH BUIL-IN 250 OHM RESISTORS. LEADS ARE DRIVEN WITH 5V VOLTAGE AND THE MAX OPERATING CURRENT IS 20mA  
 LED COLOR: DOMINATE WAVELENGTH (λD): GREEN 568 nm TYP. @ VF=5V  
 FORWARD CURRENT (IF): GREEN 12mA TYP. @VF=5V  
 DOMINATE WAVELENGTH (λD): YELLOW 588 nm TYP. @ VF=5V  
 FORWARD CURRENT (IF): YELLOW 13mA TYP. @VF=5V

△ TRP CONNECTOR LOGO, PART NUMBER, DATE CODE, COUNTRY OF ORIGIN AND AGENCY APPROVAL MARKING IN APPROXIMATE LOCATION SHOWN.

8. PART SHOULD BE RECOMMENDED FOR WAVE SOLDERING PROCESS, PREHEAT TEMPERATURE IS 120°C TO 160°C, 120 SECONDS TO 180 SECONDS, PEAK WAVE SOLDERING TEMPERATURE IS 260°C MAX, 10 SECONDS MAX.

GREEN	-	NO	GREEN	-	NO	1840632-6
YELLOW	-	YES	GREEN	-	YES	1840632-5
YELLOW	-	NO	GREEN	-	NO	1840632-4
GREEN	-	YES	GREEN	-	YES	1840632-3
GREEN	-	NO	YELLOW	-	NO	1840632-2
GREEN	YELLOW	NO	GREEN	YELLOW	NO	1840632-1
11	→	12	12	→	11	250 OHMS RESISTOR △ 6
LED 1		LED 2		PART NUMBER		

THIS DRAWING IS A CONTROLLED DOCUMENT.

ROY LIU 07APR2012  
 CHK TOWER YU/ FRANK LIU 07APR2012  
 APVD KEITH ZHU 07APR2012

TRP CONNECTOR  
 a bel group  
 DONGGUAN CHINA

MODEL NAME: MAGJACK  
 DESC: IX1 7G46PI GIGABIT TAB UP W/ LED

SIZE: A1  
 CAGE CODE: -  
 DRAWING NO: C=1840632  
 RESTRICTED TO: -

PRODUCT SPEC: -  
 APPLICATION SPEC: -

CUSTOMER DRAWING  
 SCALE: 6:1  
 SHEET: 1 OF 3  
 REV: 7

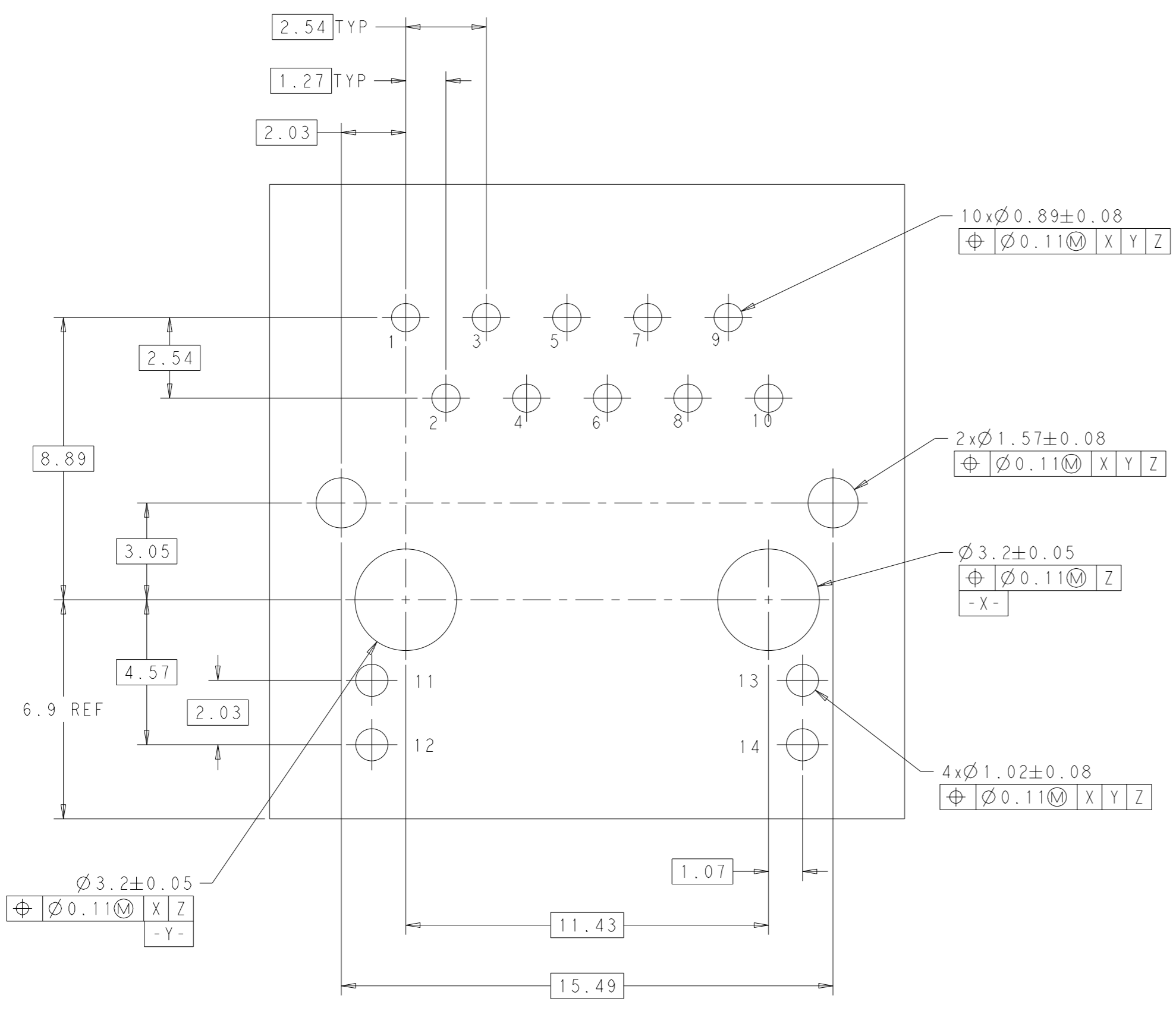

# 7G46PI GIGABIT CIRCUIT $\triangle\triangle$

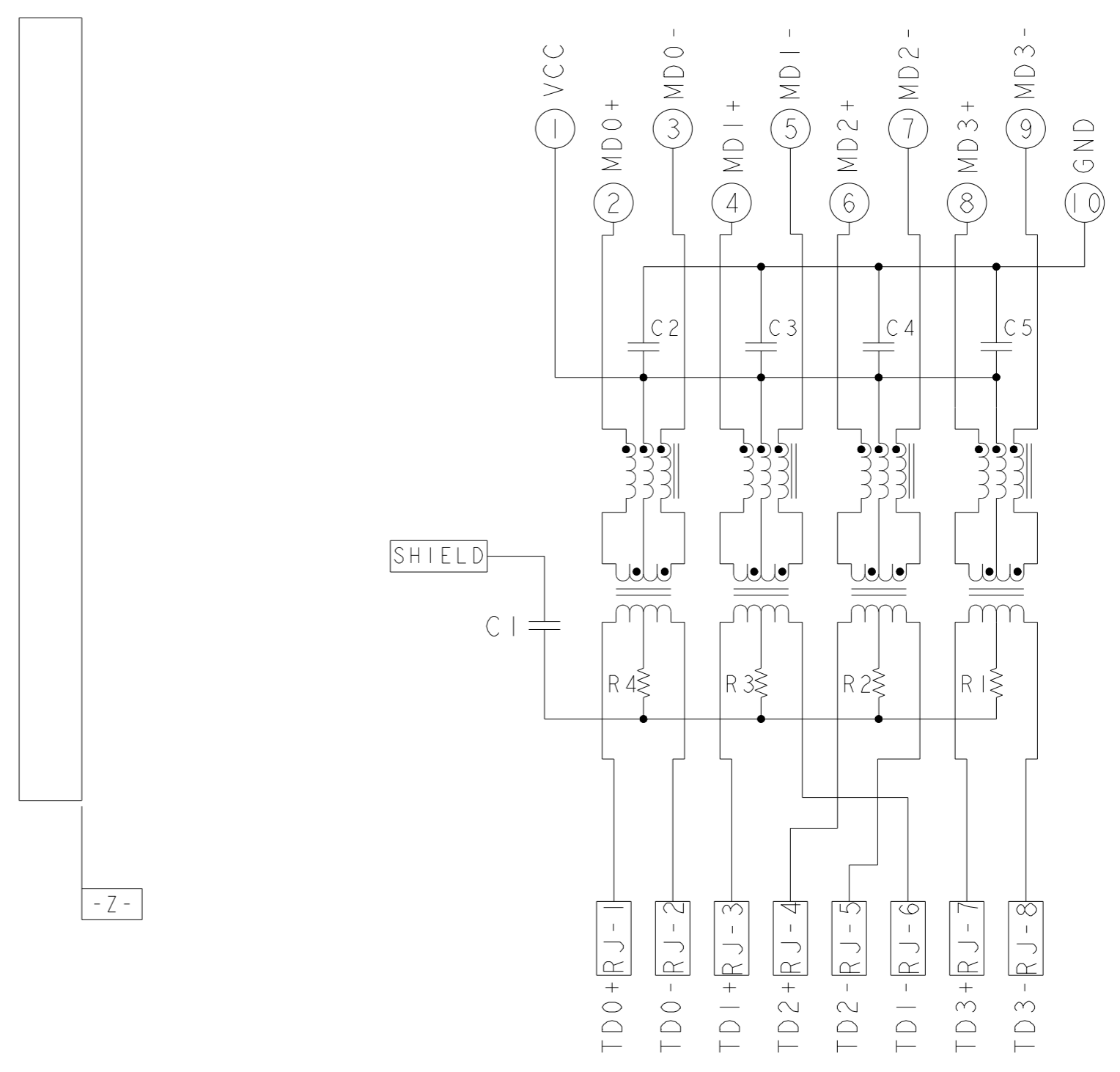

C1=1000pF, CAPACITOR  
 R1-R4=75 Ohms, RESISTORS  
 C2-C5=0.1uF, CAPACITORS

THIS DRAWING IS A CONTROLLED DOCUMENT.		DWN ROY LIU 07APR2012 CHK TOWER YU/ FRANK LIU 07APR2012 APVD KEITH ZHU 07APR2012	DONGGUAN CHINA
DIMENSIONS: mm	TOLERANCES UNLESS OTHERWISE SPECIFIED: 0 PLC $\pm 0.25$ 1 PLC $\pm 0.25$ 2 PLC $\pm 0.25$ 3 PLC $\pm 0.25$ 4 PLC $\pm 0.25$ ANGLES $\pm$ APPLICATION SPEC	MODEL NAME MAGJACK	
PRODUCT SPEC	APPLICATION SPEC	SIZE A1 CAGE CODE DRAWING NO 1840632	RESTRICTED TO SCALE 6:1 SHEET 2 OF 3 REV 7

C_1840632					STOCK DISPOSITION			
1X1 7G46P1 GIGABIT TAB UP W/ LED					A: CONTINUE AS IS B: REWORK C: SCRAP		D: USE OLD FIRST E: PARTS TO CONFORM F: OTHER	
REVISION HISTORY								
DATE	REV	CHANGES	REASON	APPROVAL	INVENTORY (A,B,C,D,E,F)	WORK IN PROCESS (A,B,C,F)	SUPPLIER ORDERS (A,E,F)	OPEN CUST ORDERS (A,E,F)
07APR2012	1	INITIAL RELEASE	-	KEITH ZHU	-	-	-	-
22MAR2013	2	1, REFRESH CORPORATION LOGO; 2, ADD DASH NUMBER 1840632-2	PER CUSTOMER REQUIREMENT	TONY YUAN	-	-	-	-
04JUN2013	3	ADD DASH NUMBER 1840632-3	MARKET REQUIREMENT	TONY YUAN	-	-	-	-
09SEP2013	4	ADD DASH NUMBER 1840632-4	PER CUSTOMER REQUIREMENT	TONY YUAN	-	-	-	-
16SEP2013	5	ADD DASH NUMBER 1840632-5	MARKET REQUIREMENT	TONY YUAN	-	-	-	-
01AUG2014	6	ADD DASH NUMBER 1840632-6	MARKET REQUIREMENT	TONY YUAN	-	-	-	-
26DEC2014	7	EC-1411035 COMPANY LOGO CHANGE	MARKET REQUEST	TONY YUAN	-	-	-	-

THIS DRAWING IS A CONTROLLED DOCUMENT.

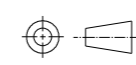
APPROVED: KEITH ZHU	DATE: 07APR2012	 <b>trp</b> CONNECTOR <small>a bel group</small>	DONGGUAN CHINA
CHECKED: TOWER YU / FRANK LIU	DATE: 07APR2012		
DESIGNED: ROY LIU	DATE: 07APR2012		
DIMENSIONS: mm 	TOLERANCES UNLESS OTHERWISE SPECIFIED: 0 PLC ±0.25 1 PLC ±0.25 2 PLC ±0.25 3 PLC ±0.25 4 PLC ±0.25 ANGLES ±°	MODEL NAME: MAGJACK DESC: 1X1 7G46P1 GIGABIT TAB UP W/ LED	SIZE: A1 CAGE CODE: - DRAWING NO: 1840632 RESTRICTED TO: -
PRODUCT SPEC: -	APPLICATION SPEC: -	CUSTOMER DRAWING	SCALE: 6:1 SHEET 3 OF 3 REV 7