



Chipsmall Limited consists of a professional team with an average of over 10 year of expertise in the distribution of electronic components. Based in Hongkong, we have already established firm and mutual-benefit business relationships with customers from,Europe,America and south Asia,supplying obsolete and hard-to-find components to meet their specific needs.

With the principle of "Quality Parts,Customers Priority,Honest Operation,and Considerate Service",our business mainly focus on the distribution of electronic components. Line cards we deal with include Microchip,ALPS,ROHM,Xilinx,Pulse,ON,Everlight and Freescale. Main products comprise IC,Modules,Potentiometer,IC Socket,Relay,Connector.Our parts cover such applications as commercial,industrial, and automotives areas.

We are looking forward to setting up business relationship with you and hope to provide you with the best service and solution. Let us make a better world for our industry!



## Contact us

Tel: +86-755-8981 8866 Fax: +86-755-8427 6832

Email & Skype: info@chipsmall.com Web: www.chipsmall.com

Address: A1208, Overseas Decoration Building, #122 Zhenhua RD., Futian, Shenzhen, China



PART NUMBER	REV	FIRST USED	POWER UNIT	FEED TYPE
1852821-1	A	122500-1	LEADMAKER & BENCH MODEL G	POST FEED
1852821-2	A	565435-5	BENCH MODEL K	POST FEED
7-1852821-7	A	-	SPARE PARTS	-

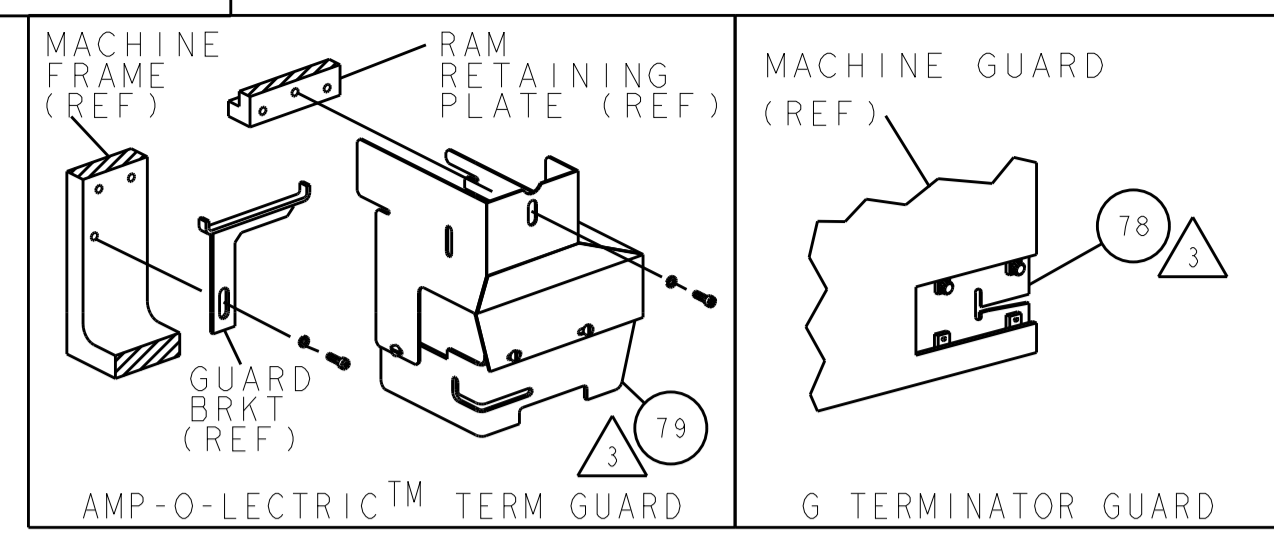

TERMINAL NAME: SPADE TERMINAL					
60251	41380	TE TERMINAL - TE CRIMP SPECS			
60355	-				
60456	-	PAD LTR	CRIMP HEIGHT	WIRE SIZE	
60600	-	A	.096±.002 [2.44±0.05mm]	14AWG	
40760	-	B	.087±.002 [2.21±0.05mm]	16AWG	
40761	-	C	.082±.002 [2.08±0.05mm]	18AWG	
40762	-	D	-	-	
40784	-	CRIMP	SIZE	TYPE	RANGE
40802	-	-	-	-	-
40803	-	WIRE	.120 [3.05mm]	F	18-14 AWG
41209	-	INSUL	.210 [5.33mm]	F	∅.130-.180
WIRE STRIP LENGTH	TERM APPL SPEC	FEED	APPL INSTRUCTIONS	SET UP GAGE	
.173-.203	114-2084	.715	408-8039	458638-1	

LOC	DIST	REVISIONS			
A	66	P LTR	DESCRIPTION	DATE	OWN
A			RELEASED	04MAR2009	LG
A1			ECR-13-017162	04NOV2013	BH
A2			ECR-13-017320	12NOV2013	BH

- △ RECOMMENDED SPARE PARTS
- △ GREASE LIGHTLY
- △ GUARD MUST BE IN PLACE WHEN OPERATING APPLICATOR IN A BENCH MACHINE

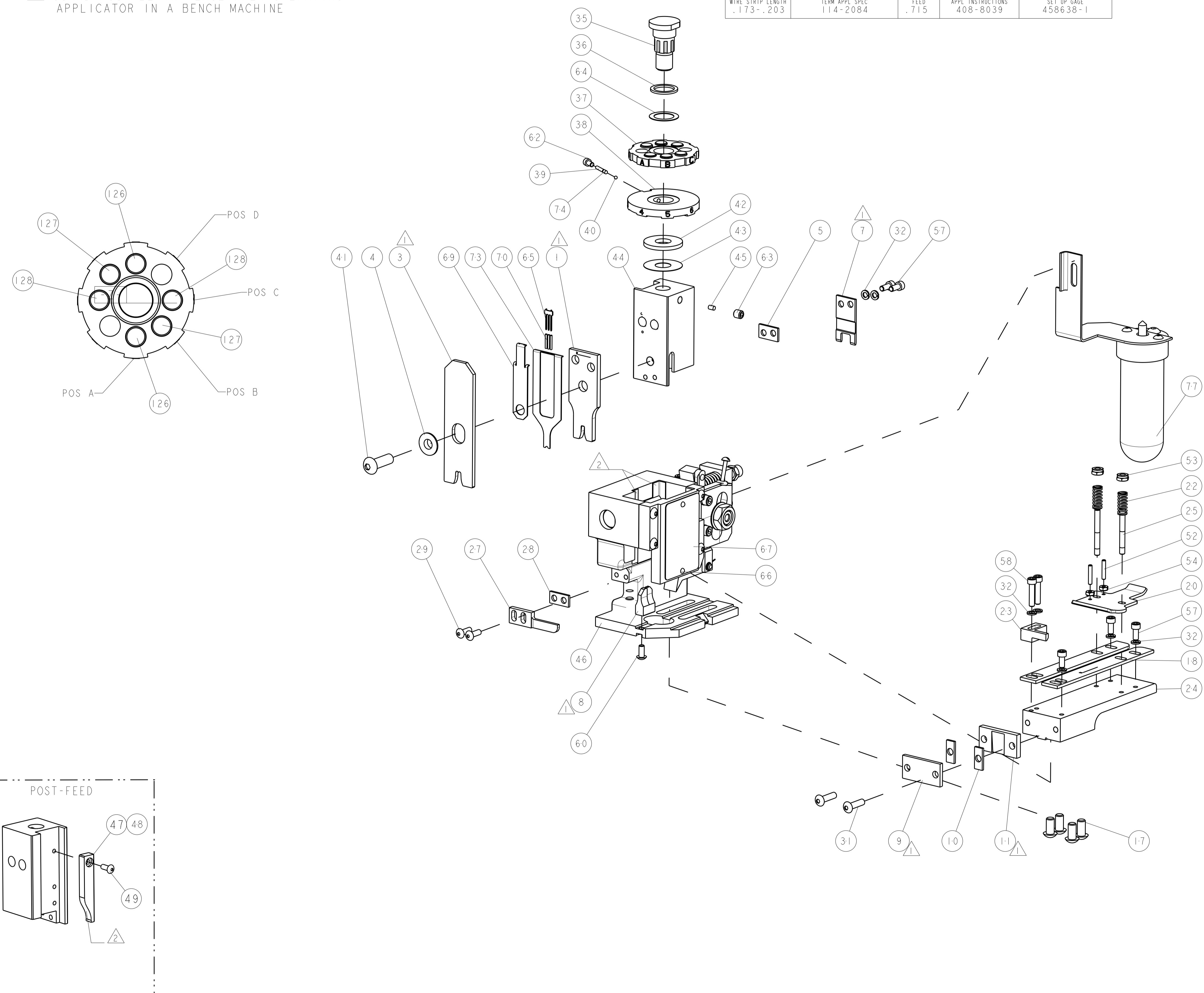

QTY	REV	LOC	DIST	DESCRIPTION	DATE	OWN	APVD
-	2	2	-	7-354778-4	PIN, WIRE DISC, .2865		128
-	2	2	-	6-354778-3	PIN, WIRE DISC, .2810		127
-	2	2	-	4-354778-4	PIN, WIRE DISC, .2715		126
△	REF	-	-	455745-1	GUARD WINDOW		79
△	-	REF	-	679532-1	INSERT, GUARD		78
-	1	-	-	465184-9	LUBRICATOR ASSY		77
-	1	1	-	690603-1	SPRING ASSIST AMP-O-MATOR APPLICATOR		74
-	1	1	-	1490525-3	DEPRESSOR, WIRE		73
-	1	1	-	217238-1	GENERAL INSTRUCTION PKG		72
-	1	1	-	4088039	EF APPL INST 408-8039		71
-	3	3	-	2-23147-2	SPRING, COMPRESSION		70
-	1	1	-	1490524-1	DEPRESSOR, SPACER		69
-	1	1	-	461264-1	PLATE, IDENTIFICATION		67
-	2	2	-	21017-2	SCREW, DRIVE		66
-	1	1	-	1424350-1	HOLDER, PIN, WIRED		65
-	1	1	-	986950-1	WASHER, FLAT PRECISION		64
-	1	1	-	21009-2	SCR, SET, SELF LOCKING 1/4-20 X .250		63
-	1	1	-	23030-1	SCR, SKT HD CAP 6-32 X .25		62
-	1	1	-	22733-8	SCR, BHSC, SELF-LOCKING, 8-32 X .375		60
-	2	2	-	2-21000-9	SCR, SKT HD CAP 8-32 X .750		58
-	3	3	-	2-21000-6	SCR, SKT HD CAP 8-32 X .375		57
-	2	2	-	2-21000-6	SCR, SKT HD CAP 8-32 X .375		56
-	2	2	-	21018-4	NUT, HEX, REG 4-40		54
-	2	2	-	21022-2	NUT, LOCK, HEX, TORQUE, 8-32		53
-	2	2	-	2-21006-6	SCR, SET, CUP POINT 4-40 X .625		52
-	1	1	-	1-21002-7	SCR, BTN SKT CAP 6-32 X .375		49
-	1	-	-	690501-3	CAM, POST FEED, 1 1/8		48
-	-	1	-	690501-4	CAM, POST-FEED 1 5/8		47
-	1	1	-	458980-1	SUB ASSY, APPLICATOR FRAME		46
-	1	1	-	690191-1	PLUG, NYLON		45
-	1	1	-	455674-1	RAM		44
-	1	1	-	690125-1	SHIM SUB-ASSY		43
-	1	1	-	690124-1	WASHER, RAM (.115)		42
-	1	1	-	7-21002-9	SCR, BTN SKT HD CAP 5/16-24 X 1.00		41
-	1	1	-	23241-6	BALL, STEEL		40
-	1	1	-	690170-1	SPRING, COMPRESSION		39
-	1	1	-	690142-1	DISC, INSULATION		38
-	1	1	-	354777-1	WIRE DISC, ASSEMBLY		37
-	1	1	-	22480-5	SPRING, COMPRESSION		36
-	1	1	-	690212-1	POST, RAM		35
-	7	7	-	21024-4	WASHER, SPRG LOCK, REG NO 8		32
-	2	2	-	2-21002-9	SCR, BTN SKT HD CAP 10-32 X .750		31
-	2	2	-	2-21002-2	SCR, BTN SKT HD CAP 8-32 X .500		29
-	1	1	-	3-690451-2	SPACER, STRIPPER		28
-	1	1	-	240639-1	STRIPPER (MACHINING)		27
-	2	2	-	22354-8	STUD, THREADED		25
-	1	1	-	455678-1	PLATE, STRIP GUIDE		24
-	1	1	-	240825-3	PLATE, STRIP HOLD DOWN		23
-	2	2	-	4-22281-1	SPRING, DRAG		22
-	1	1	-	454177-1	DRAG		20
-	2	2	-	454204-3	GUIDE, LOWER STRIP		18
-	4	4	-	3-21002-3	SCR, BTN SKT HD CAP 1/4-20 X .500		17
△	1	1	-	240644-1	PLATE, REAR SHEAR		11
△	2	2	-	240645-7	SPACER, SHEAR PLATE		10
△	1	1	-	240642-1	PLATE, FRONT SHEAR		9
△	1	1	-	3-240693-8	ANVIL, COMBINATION		8
△	1	1	-	1-240651-3	BLADE, SLUG		7
-	-	-	-	-	-		6
-	1	1	-	3-240641-3	SPACER		5
-	1	1	-	238009-1	BLOCK, FL CRIMPER SPACER		4
△	1	1	-	1-456134-1	CRIMPER, INSULATION F PREMIUM		3
△	1	1	-	456409-3	CRIMPER, WIRE .120 "F" PREMIUM		1

QTY	REV	LOC	DIST	PART NO	DESCRIPTION	ITEM NO
-77	-2	-1	U/M			

DIMENSIONS: INCHES 		TOLERANCES UNLESS OTHERWISE SPECIFIED: 0 PLC ±.001 1 PLC ±.01 2 PLC ±.001 3 PLC ±.001 4 PLC ±.0001 ANGLES ±.0001		DWG: L.ZHANG 16FEB2009 CHK: S.ZOU 16FEB2009 APVD: W.DEMING 16FEB2009 NAME: END FEED HDM APPLICATOR PRODUCT SPEC: - APPLICATION SPEC: - SIZE: A1 CAGE CODE: 00779 DRAWING NO: 1852821 SCALE: 3:5 SHEET: 1 OF 1 REV: A2	
---------------------------	--	--	--	--	--