



Chipsmall Limited consists of a professional team with an average of over 10 year of expertise in the distribution of electronic components. Based in Hongkong, we have already established firm and mutual-benefit business relationships with customers from,Europe,America and south Asia,supplying obsolete and hard-to-find components to meet their specific needs.

With the principle of “Quality Parts,Customers Priority,Honest Operation,and Considerate Service”,our business mainly focus on the distribution of electronic components. Line cards we deal with include Microchip,ALPS,ROHM,Xilinx,Pulse,ON,Everlight and Freescale. Main products comprise IC,Modules,Potentiometer,IC Socket,Relay,Connector.Our parts cover such applications as commercial,industrial, and automotives areas.

We are looking forward to setting up business relationship with you and hope to provide you with the best service and solution. Let us make a better world for our industry!



Contact us

Tel: +86-755-8981 8866 Fax: +86-755-8427 6832

Email & Skype: info@chipsmall.com Web: www.chipsmall.com

Address: A1208, Overseas Decoration Building, #122 Zhenhua RD., Futian, Shenzhen, China



THIS DRAWING IS UNPUBLISHED. RELEASED FOR PUBLICATION
 © COPYRIGHT - y ALL RIGHTS RESERVED.

| LOC | | DIST | | REVISIONS | | | |
|-----|-----|-------------|---------|-----------|------|-----|--|
| P | LTR | DESCRIPTION | DATE | DWN | APVD | | |
| IR | - | D | REVISED | 14NOV2016 | M.T | K.K | |

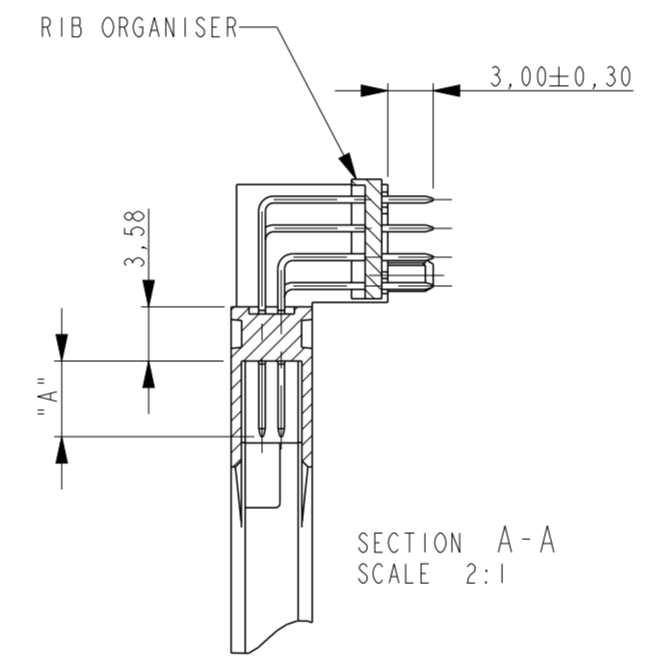
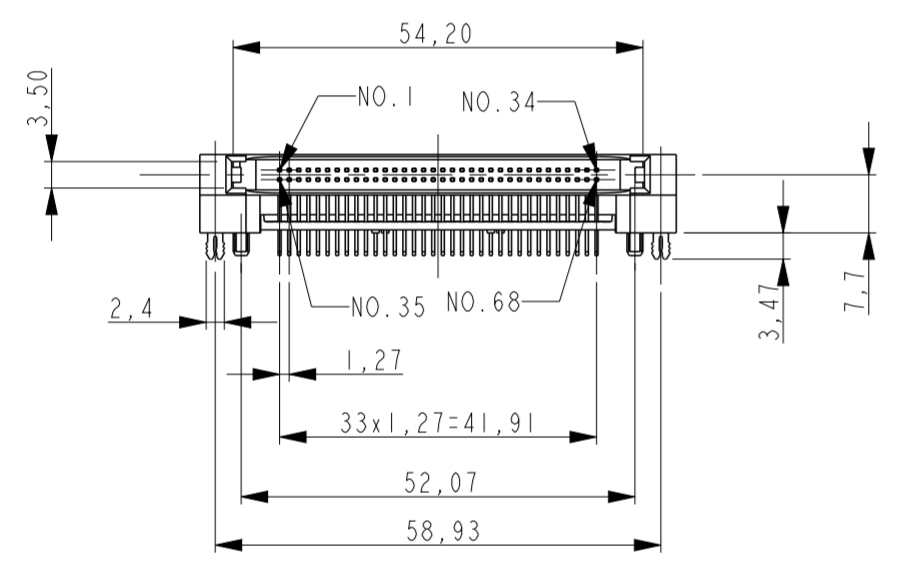
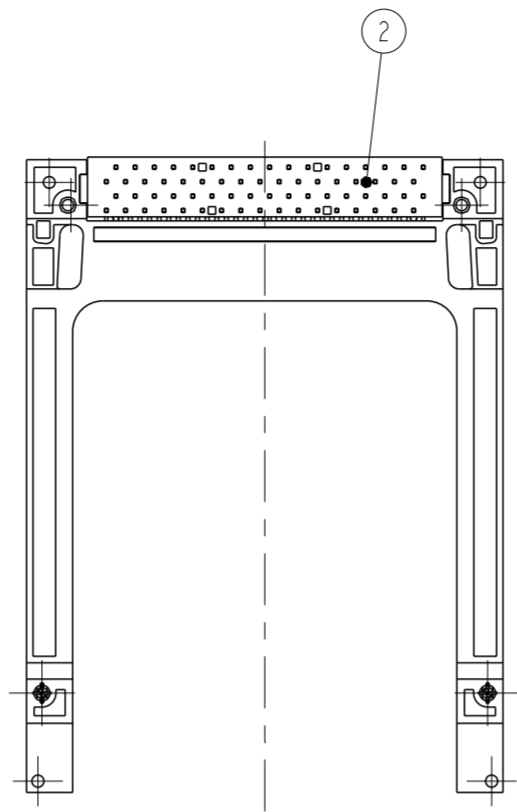
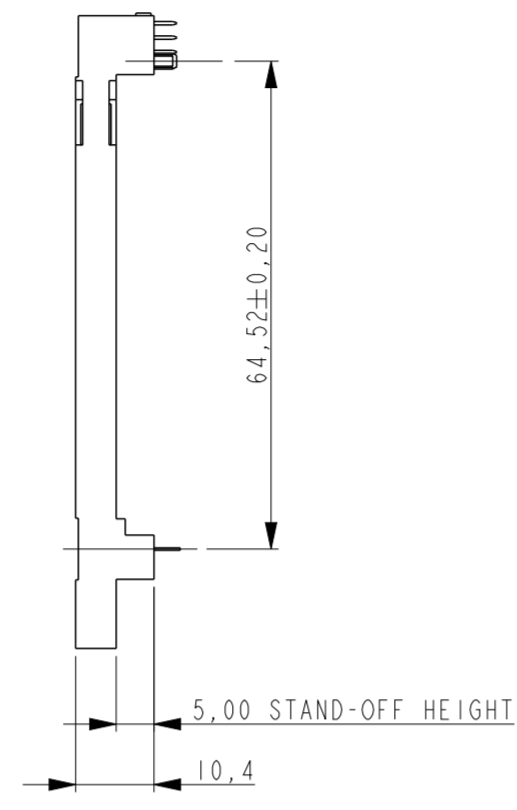
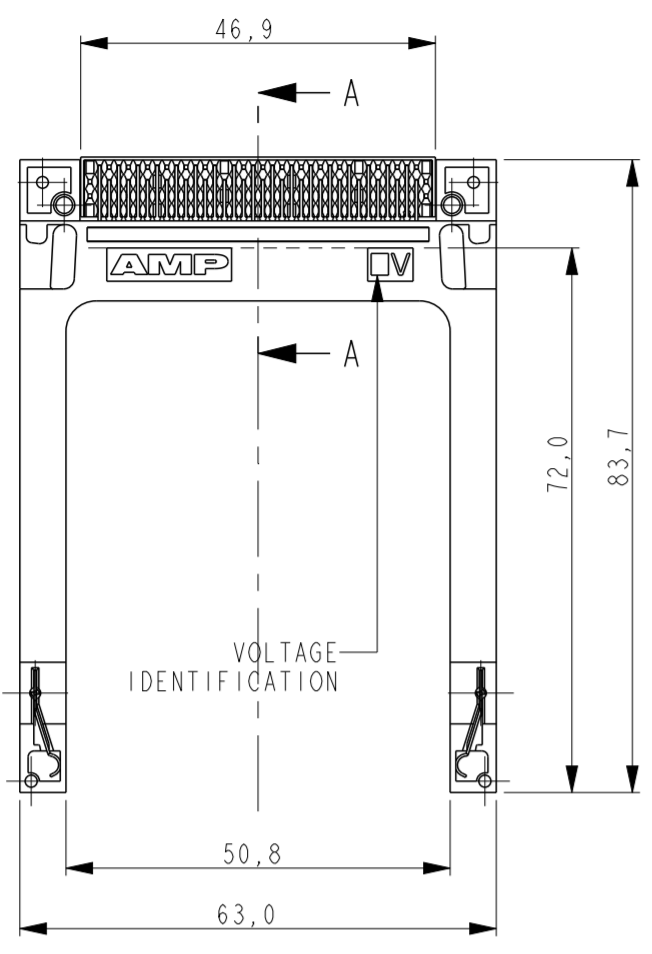

NOTES/SPECIFICATION:

- HEADER ACCEPTS TYPES I, II, & III OF PCMCIA STANDARD MEMORY CARD
- MECHANICAL SPECIFICATION:
 - DURABILITY
 - OFFICE ENVIRONMENT: 10000 CYCLES MINIMUM
 - HARSH ENVIRONMENT: 5000 CYCLES
 - CONTACT RETENTION FORCE: 1Kg MINIMUM
- ELECTRICAL SPECIFICATION:
 - CONTACT RESISTANCE: 40 MILLI OHMS MAX.
 - DIELECTRIC WITHSTANDING VOLTAGE: 500 Vrms FOR 1min.
 - INSULATION RESISTANCE: 1000 MEGA OHMS MIN.
 - CURRENT CAPACITY: 0,5 AMPS PER PIN.
- ENVIRONMENTAL SPECIFICATIONS:
 - STORAGE ENVIRONMENT: -40°C TO +70°C, 95% MAX. RELATIVE HUMIDITY (NON CONDENSING)
 - OPERATION TEMPERATURE: -20°C TO +60°C, 95% MAX. RELATIVE HUMIDITY (NON CONDENSING)
 - THERMAL SHOCK: 6 CYCLES (1 CYCLE PER HOUR) WITH CONNECTOR ENGAGED WITH EXTREMES OF -55°C TO +70°C.
- LENGTH OF CONTACTS:

| DIM "A" | POSITION No. |
|---------|-----------------------|
| 5 | 1, 17, 34, 35, 51, 68 |
| 3.5 | 36, 67 |
| 4.25 | THE OTHERS |
- PLATING OF CONTACT:
 - Ni : OVERALL
 - Au : CARD SIDE
 - TIN: PCB SIDE
- ALL PARTS PACKAGED IN TRAYS UNLESS REQUESTED:

CONNECTOR TO PRINTED CIRCUIT BOARD ASSEMBLY:

- PLACE THE CONNECTOR ON THE PRINTED CIRCUIT BOARD. THE SOLDER TAILS, RETENT CLIPS & PLASTIC LEGS SHOULD BE SEATED IN THE RESPECTIVE HOLES.
- PUSH FIRMLY DOWN ON CENTER OF PLASTIC LEGS THEN SOLDER RETENTS. A SLIGHT SNAP IS FELT WHEN THE CONTACT IS FULLY SEATED.
- SOLDER PROCESS ENTIRE PRINTED CIRCUIT BOARD ASSEMBLY.

RECOMMENDED PCB LAYOUT
 (THICKNESS: 1,60mm ±0,1mm)

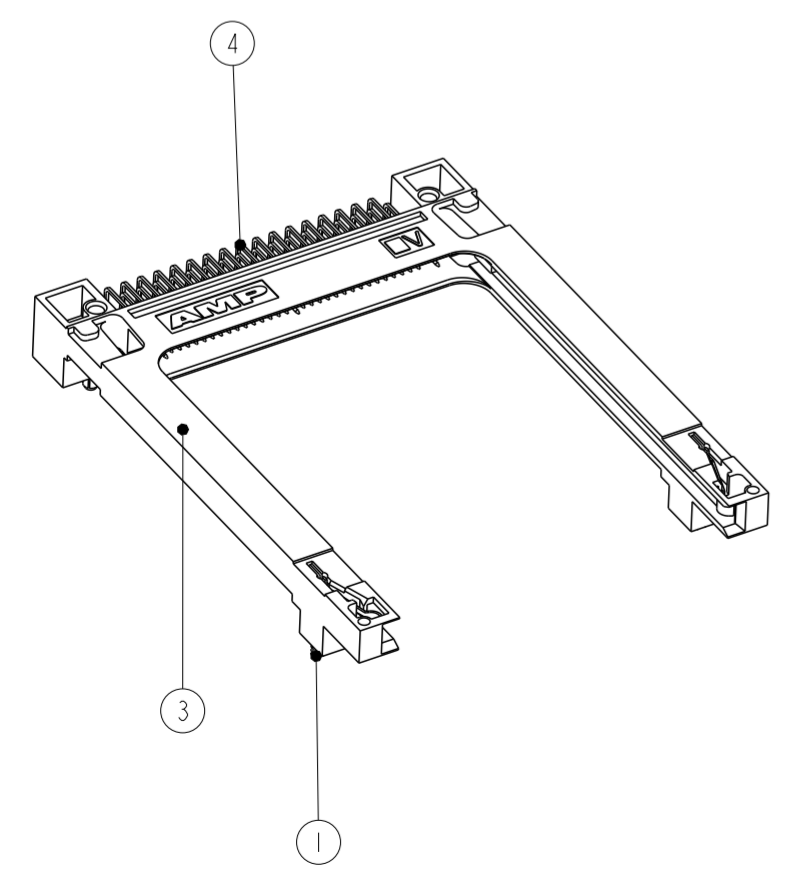
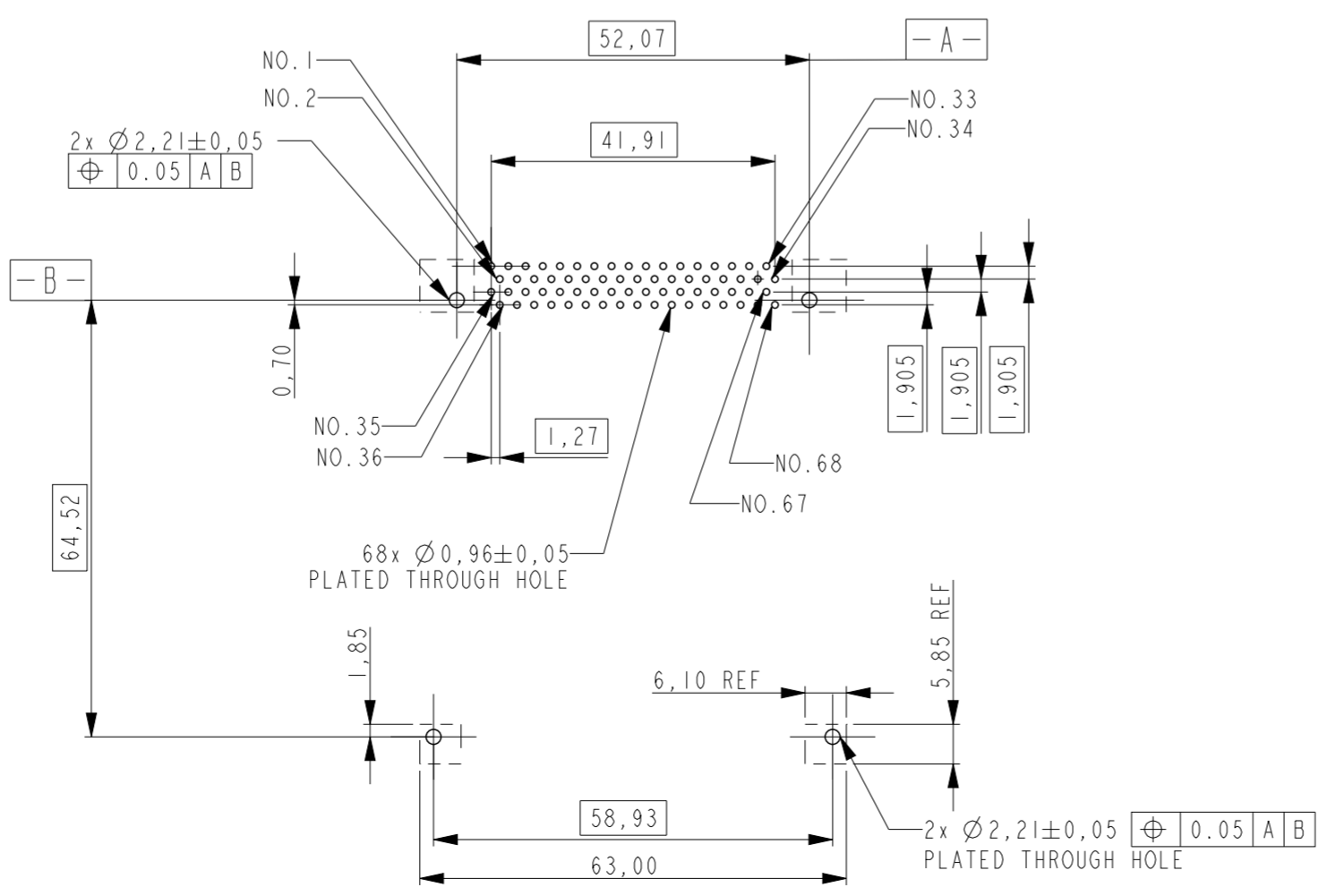

| | | |
|----------|----------------------|------------------------|
| | 1857246-2 | 3.3V |
| OBSOLETE | 1857246-1 | 5.0V |
| | TE PN. | VOLTAGE IDENTIFICATION |

| ITEM NO | QTY | DESCRIPTION | MATERIAL | FINISH |
|---------|-----|----------------|-----------------------|--------------|
| 4 | 68 | CONTACT | COPPER ALLOY | ⚠ |
| 3 | 1 | HOUSING | THERMOPLASTIC UL94 V0 | COLOR: BLACK |
| 2 | 1 | ORGANISER | THERMOPLASTIC UL94 V0 | COLOR: BLACK |
| 1 | 2 | GROUND CONTACT | PHOSPHOR BRONZE | TIN: 2µm MIN |

THIS DRAWING IS A CONTROLLED DOCUMENT.

DWN: P. Willems 04-AUG-05
 CHK: P. Willems 04-AUG-05
 APVD: J. Broeksteeg
 PRODUCT SPEC: 108-19201
 APPLICATION SPEC: -

STE TE Connectivity

NAME: PC CARD HEADER HIGH RAISED 5mm
 0,7mm OFFSET

MATERIAL: SEE TABLE

SIZE: A2 CAGE CODE: 00779 DRAWING NO: C-1857246 RESTRICTED TO: -

WEIGHT: -

CUSTOMER DRAWING SCALE: 1:1 SHEET: 1 OF 1 REV: D