



Chipsmall Limited consists of a professional team with an average of over 10 year of expertise in the distribution of electronic components. Based in Hongkong, we have already established firm and mutual-benefit business relationships with customers from,Europe,America and south Asia,supplying obsolete and hard-to-find components to meet their specific needs.

With the principle of "Quality Parts,Customers Priority,Honest Operation,and Considerate Service",our business mainly focus on the distribution of electronic components. Line cards we deal with include Microchip,ALPS,ROHM,Xilinx,Pulse,ON,Everlight and Freescale. Main products comprise IC,Modules,Potentiometer,IC Socket,Relay,Connector.Our parts cover such applications as commercial,industrial, and automotives areas.

We are looking forward to setting up business relationship with you and hope to provide you with the best service and solution. Let us make a better world for our industry!



Contact us

Tel: +86-755-8981 8866 Fax: +86-755-8427 6832

Email & Skype: info@chipsmall.com Web: www.chipsmall.com

Address: A1208, Overseas Decoration Building, #122 Zhenhua RD., Futian, Shenzhen, China



THIS DRAWING IS UNPUBLISHED. RELEASED FOR PUBLICATION
 © COPYRIGHT BY TYCO ELECTRONICS CORPORATION. ALL RIGHTS RESERVED.

Loc	DIST	REVISIONS					
		P	LTR	DESCRIPTION	DATE	DWN	APVD
H	-	A1		ECR-07-024984	19OCT2007	JvH	JB
		B		ECR-10-018652	10SEP10	SW	MQW
		C		ECO-11-024491	13DEC11	SY	MQW

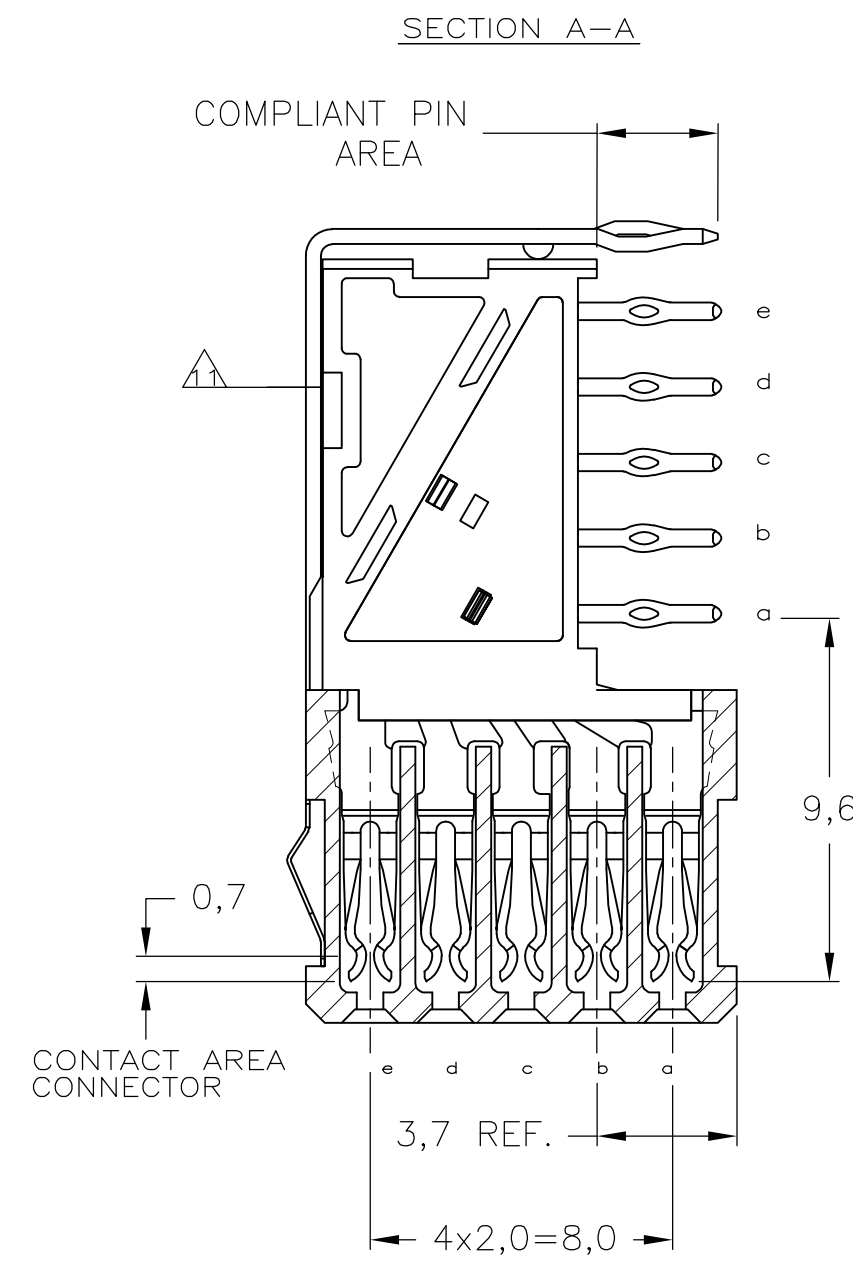
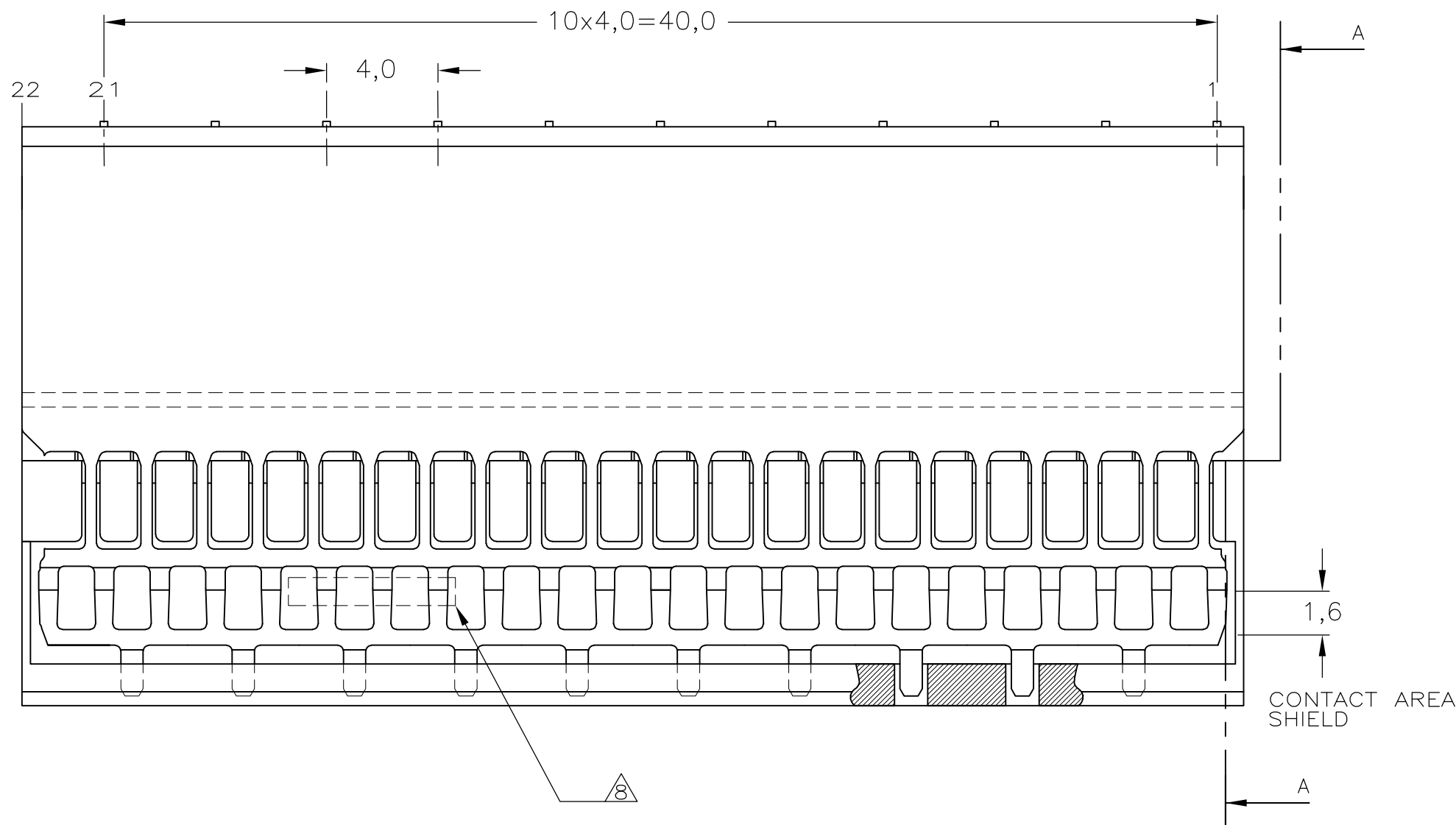

- NOTES:
- ⚠ MATERIAL CONTACTS; PHOSPHORBRONZE
 - ⚠ MATERIAL HOUSING; GLASSFILLED POLYESTER (GRAY)
 - ⚠ GENERAL PLATING SPECIFICATION: UNDERPLATING (ENTIRE CONTACT): 1,27μm NICKEL MIN. AND COMPLIANT PIN SECTION: 0,5μm TIN MIN. FOR PLATING OF MATING SURFACES SEE APPLICABLE SPECIFICATION REFERENCE FOR EACH DASH NUMBER.
 - ⚠ CONFORMS TO ALL TESTING ACCORDING IEC 61076-4-101 PERFORMANCE LEVEL 2.
 - ⚠ CONFORMS TO ALL TESTING ACCORDING IEC 61076-4-101 PERFORMANCE LEVEL 1.
 - ⚠ CONNECTOR TESTED AND QUALIFIED AGAINST TELCORDIA GR-1217-CORE QUALITY LEVEL III, CENTRAL OFFICE APPLICATIONS.
 - ⚠ CONNECTOR LUBRICATED WITH TELCORDIA GR-1217-CORE APPROVED LUBRICANT.
 - ⚠ PLATING SHIELD: μm Au MIN.
 - ⚠ CONTACT AREA: 0,76
 - ⚠ COMPLIANT PIN SECTION: 0,5μm Sn MIN.
 - ⚠ REMAINDER : Ni
 - ⚠ ASSEMBLY PRINTED WITH P/N AND DATECODE
 - ⚠ THE MARKING CAN APPEAR ON THE FRONT SIDE OR BACK SIDE.
 - ⚠ HOLE PATTERN FOR FEMALE CONNECTOR TYPE B-22 COLUMNS 110 PLATED-THROUGH HOLES AT 2x2mm SQUARE GRID
 - ⚠ ROW "f" 11 PLATED THROUGH HOLES FOR UPERSHIELD
 - ⚠ SHIELD MOUNTED ON CONNECTOR WITH DOUBLE SIDED ADHESIVE TAPE OR ADHESIVE.
 - 12 BASIC P.N. LOWERSHIELD : 5352468.

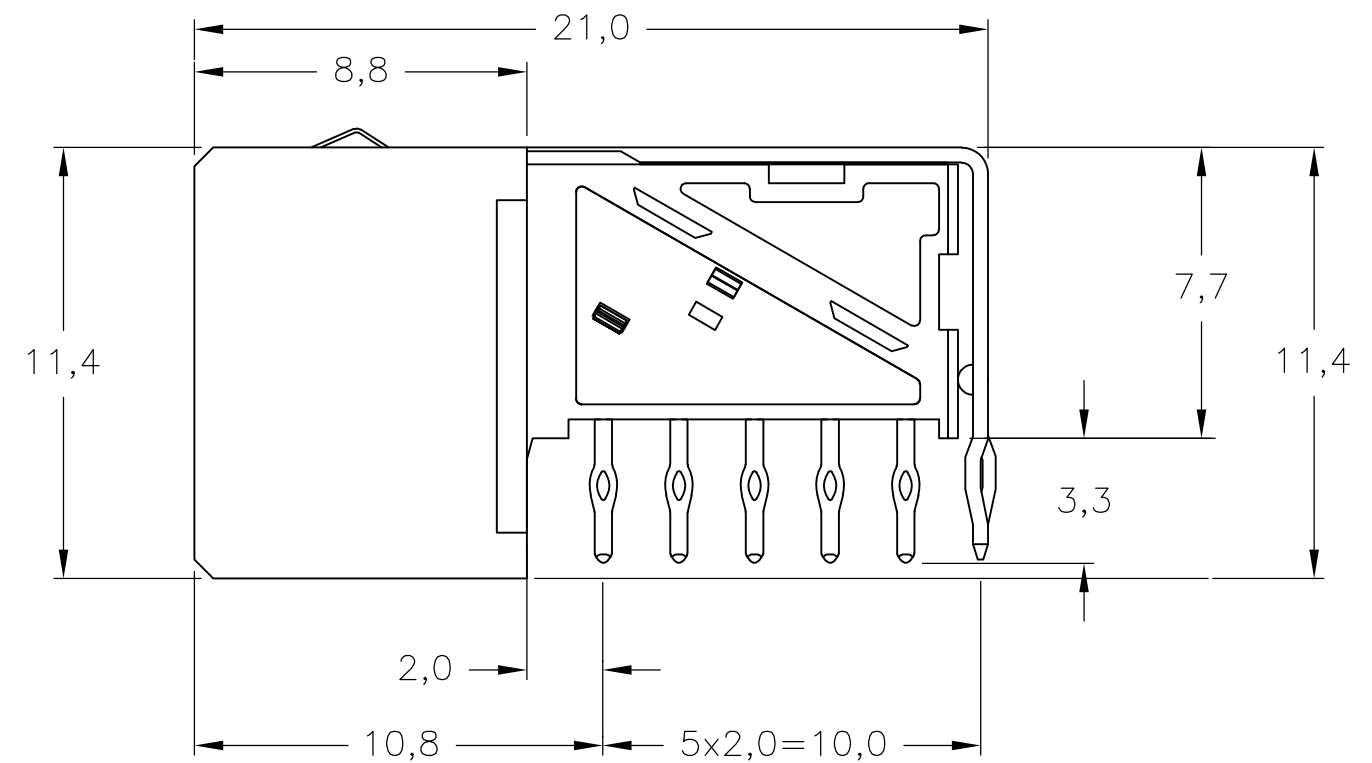
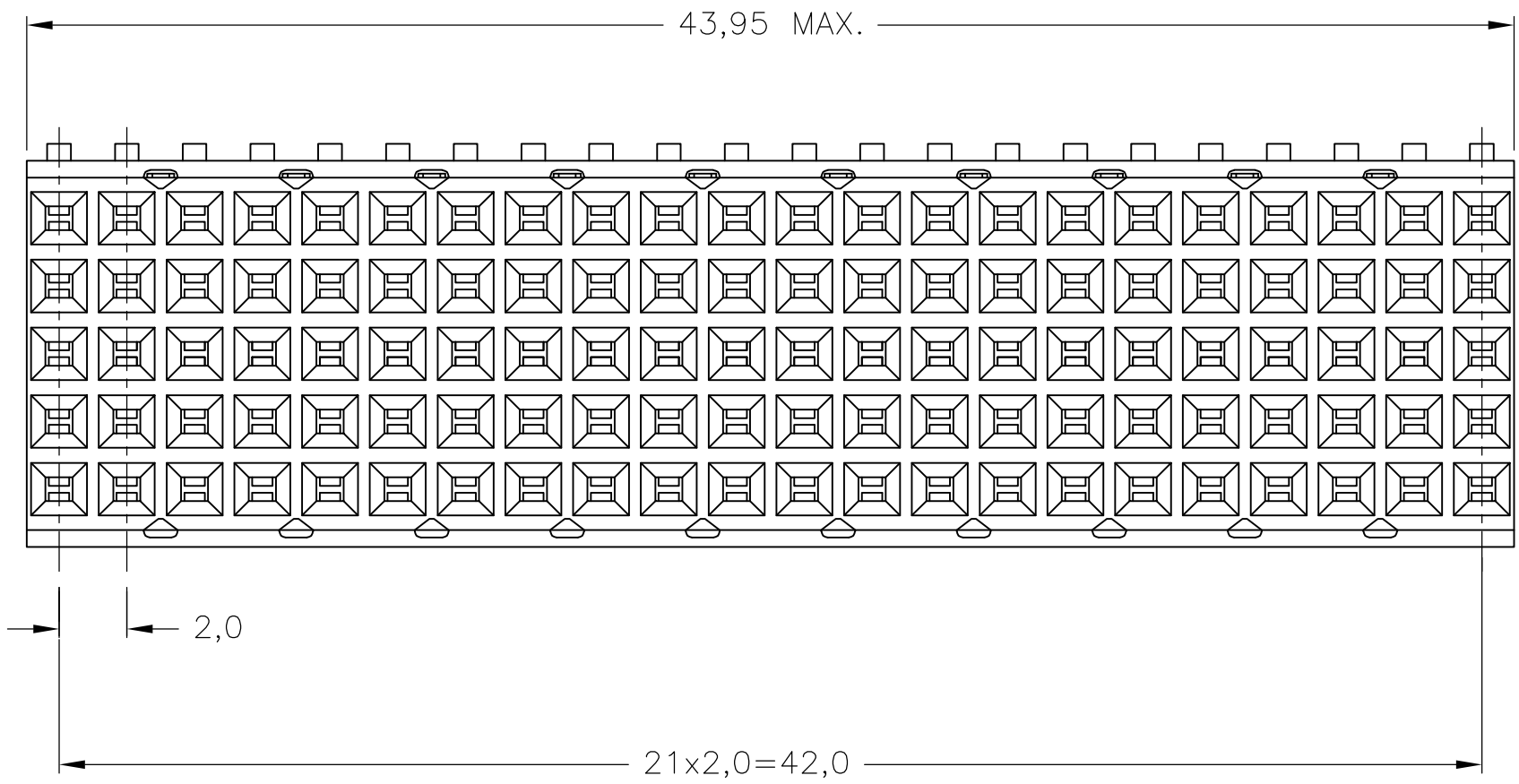

COMPONENT SIDE AS SHOWN
 RECOMMENDED PCB-HOLE LAY-OUT
 SCALE 2,5:1

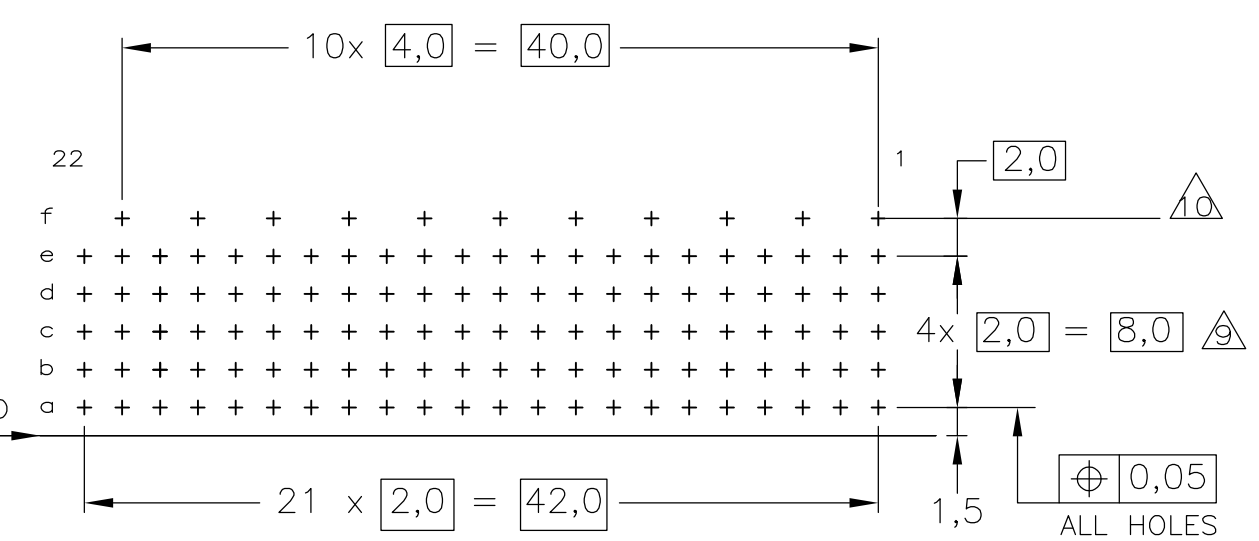

P.C.B. HOLE DIM. COMPLIANT PIN
 FOR DETAILS SEE
 APPLICATION SPECIFICATION

THIS DRAWING IS A CONTROLLED DOCUMENT.		DWN J.van Hoek 23AUG2007	Tyco Electronics Corporation	
DIMENSIONS: mm		CHK B.Mooij 23AUG2007	's-Hertogenbosch,5222AR-32	
TOLERANCES UNLESS OTHERWISE SPECIFIED:		APVD J.Broeksteeg 23AUG2007	NAME	
0-PLG ±		PRODUCT SPEC	Z-PACK 2mm HM	
1-PLG ±		APPLICATION SPEC	TYPE B - 22 COLUMNS	
2-PLG ± ±0.2		108-19082	PRE-SHIELDED RECEPTACLE	
3-PLG ±		114-19029	SIZE A2	CAGE CODE 00779
4-PLG ±		WEIGHT -	DRAWING NO C=1857997	RESTRICTED TO -
ANGLES ±		MATERIAL -	SCALE 5:1	SHEET 1 OF 1
FINISH -		CUSTOMER DRAWING	REV C	