



Chipsmall Limited consists of a professional team with an average of over 10 year of expertise in the distribution of electronic components. Based in Hongkong, we have already established firm and mutual-benefit business relationships with customers from,Europe,America and south Asia,supplying obsolete and hard-to-find components to meet their specific needs.

With the principle of “Quality Parts,Customers Priority,Honest Operation,and Considerate Service”,our business mainly focus on the distribution of electronic components. Line cards we deal with include Microchip,ALPS,ROHM,Xilinx,Pulse,ON,Everlight and Freescale. Main products comprise IC,Modules,Potentiometer,IC Socket,Relay,Connector.Our parts cover such applications as commercial,industrial, and automotives areas.

We are looking forward to setting up business relationship with you and hope to provide you with the best service and solution. Let us make a better world for our industry!



## Contact us

Tel: +86-755-8981 8866 Fax: +86-755-8427 6832

Email & Skype: info@chipsmall.com Web: www.chipsmall.com

Address: A1208, Overseas Decoration Building, #122 Zhenhua RD., Futian, Shenzhen, China



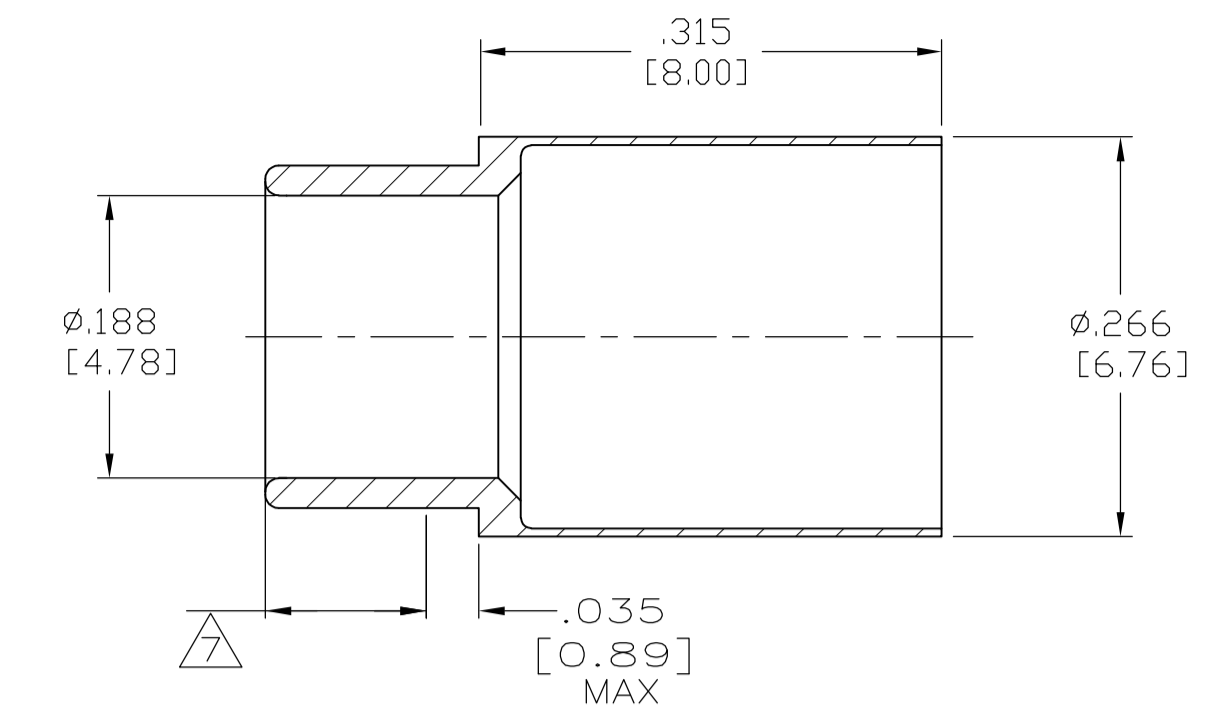

1 4  
FERRULE

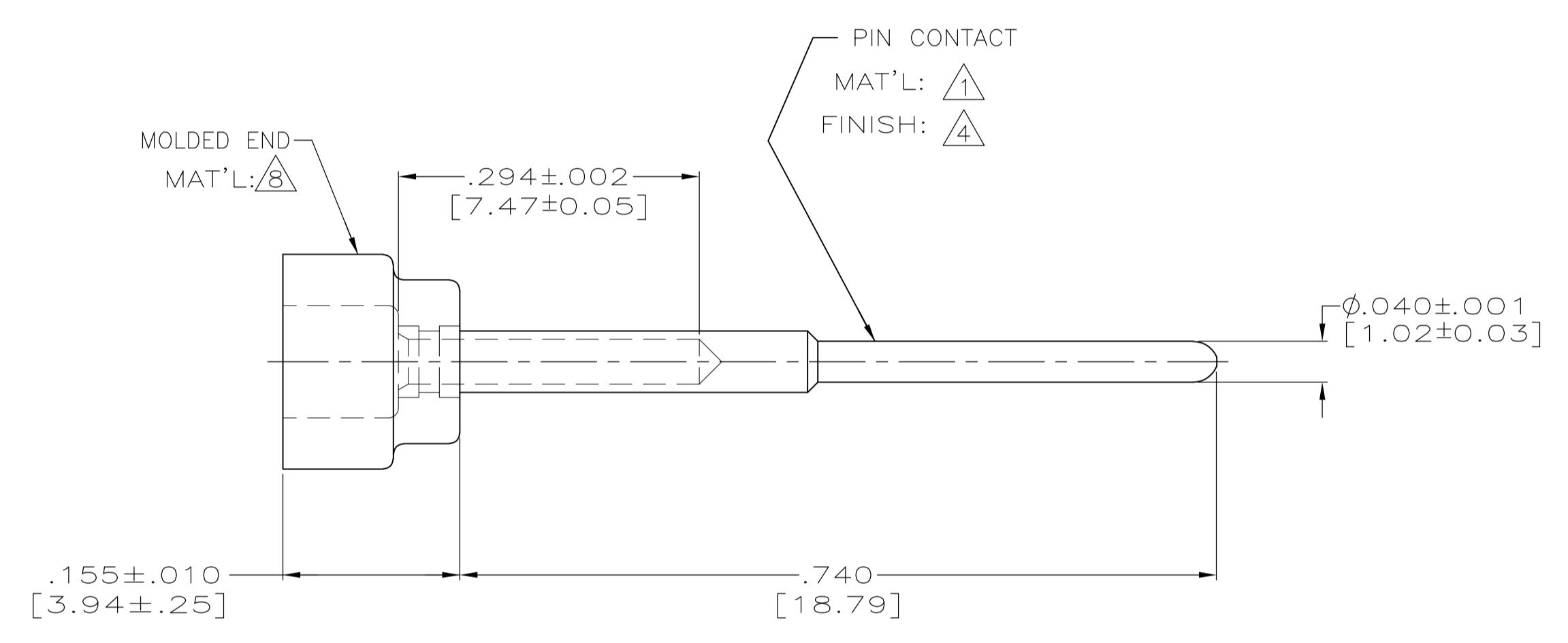
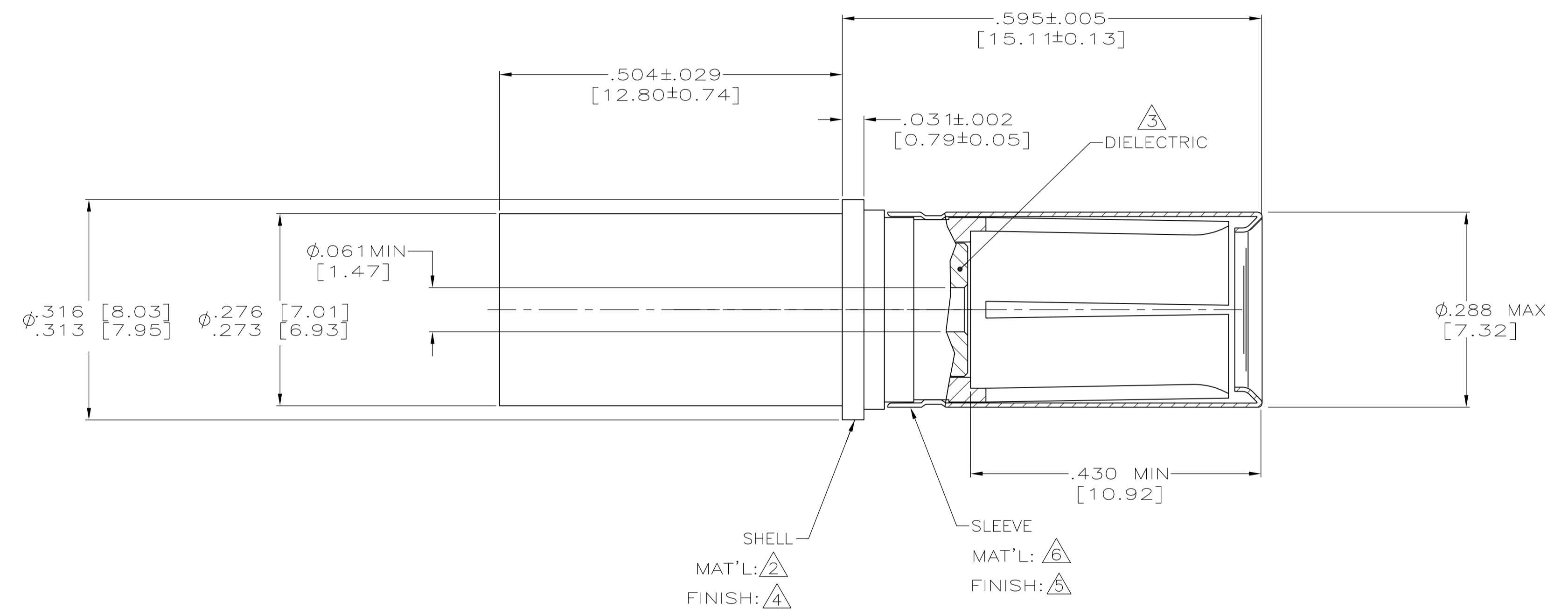

ASSEMBLY PROCEDURE

- STRIP OUTER INSULATION BACK FROM END OF CABLE 1.00 INCH.
- SLIGHTLY FLARE THE SHIELD AND TRIM APPROXIMATELY .25" OF THE DIELECTRIC, CENTER CONDUCTOR AND FILLER.
- SLIDE INNER CRIMP FERRULE, LARGEST END FIRST, OVER THE SHIELD UNTIL IT BOTTOMS ON THE OUTER INSULATION.
- COMB OUT SHIELD. FOLD SHIELD BACK OVER THE INNER CRIMP FERRULE. TRIM THE SHIELD EVEN WITH THE BACK EDGE OF THE KNURLED AREA.
- TRIM THE DIELECTRIC .10 INCH FROM THE SHIELD
- TRIM THE FILLER FLUSH WITH THE END OF THE DIELECTRIC.
- TRIM THE CENTER CONDUCTOR .30 INCH FROM THE END OF THE DIELECTRIC.
- PLACE THE OUTER CONTACT BODY OVER THE CENTER CONDUCTOR AND SLIDE IT OVER THE SHIELD. ENSURE THAT NO SHIELD STRANDS PROTRUDE FROM BETWEEN THE OUTER CONTACT BODY AND THE INNER CRIMP FERRULE.
- REMOVE THE OUTER CONTACT BODY AND TRIM THE SHIELD AS NEEDED.
- PLACE THE PIN CONTACT SUB-ASSEMBLY INTO A M22520/2-01 CRIMPING TOOL, SIDE OPPOSITE THE SELECTOR SWITCH. THE PLASTIC HOUSING ON THE PIN CONTACT SERVES AS A LOCATOR. SET CRIMP TOOL SELECTOR SWITCH TO #5. INSERT CENTER CONDUCTOR INTO CONTACT INSURING CABLE DIELECTRIC ENTERS PLASTIC AND HOUSING AND CENTER CONDUCTOR IS VISIBLE THRU VIEW HOLE IN CENTER CONTACT. CRIMP CONTACT.
- SLIDE CRIMPED CONTACT SUB-ASSEMBLY INTO OUTER CONTACT BODY FIRMLY SEATING FERRULE. CRIMP FERRULE USING PROCRIMPER HANDTOOL #354940-1 AND DIE SET 58436-1 OR HANDTOOL M22520/5-01 WITH M22520/5-07 OR EQUIVALENT DIE SET. CRIMP USING .255" HEX CRIMP. POSITION CONTACT IN HEX CRIMPING TOOL SO DIVIDING LINE OF FERRULE AND CONTACT BODY IS APPROXIMATELY IN THE CENTER OF THE CRIMPING DIE.

- 1 MAT'L: BRASS PER ASTM-B-16
- 2 MAT'L: BERYLLIUM COPPER PER ASTM-B-196.
- 3 MAT'L: PTFE PER ASTM-D-1710.
- 4 FINISH: GOLD PLATE PER ASTM-B-488, TYPE 1, GRADE C, CLASS 1 OVER NICKEL .000050 [0.0013] THK PER AMS-QQ-N-290, CLASS 2.
- 5 FINISH: PASSIVATE PER AMS-QQ-P-35.
- 6 MAT'L: STAINLESS STEEL PER ASTM-A-240.
- 7 160 DP. FULL DIAMOND KNURL OVER THIS LENGTH.
- 8 MAT'L: POLYESTER MLDG. CMPD. PER MIL-M-24519, TYPE C.

AFC-240-75	1883434-1
CABLE	PART NO.

THIS DRAWING IS A CONTROLLED DOCUMENT.		DWN C.C.THOMAS 8-16-06	Tyco Electronics Corporation Harrisburg, PA 17105-3608
DIMENSIONS: INCHES [mm]		CHK R.GROSS 8-16-06	
TOLERANCES UNLESS OTHERWISE SPECIFIED:		APVD R.GROSS 8-16-06	NAME SOCKET CONTACT ASSY.COAX, SIZE 8,REAR RELEASE
0 PLC ± -		PRODUCT SPEC	
1 PLC ± -		APPLICATION SPEC	SIZE A1
2 PLC ± -		WEIGHT	CAGE CODE 00779
3 PLC ± .005 [0.13]		CUSTOMER DRAWING	DRAWING NO 1883434
4 PLC ± -		SCALE 8:1	SHEET 1 OF 1
ANGLES ± -		REV C	