



Chipsmall Limited consists of a professional team with an average of over 10 year of expertise in the distribution of electronic components. Based in Hongkong, we have already established firm and mutual-benefit business relationships with customers from,Europe,America and south Asia,supplying obsolete and hard-to-find components to meet their specific needs.

With the principle of "Quality Parts,Customers Priority,Honest Operation,and Considerate Service",our business mainly focus on the distribution of electronic components. Line cards we deal with include Microchip,ALPS,ROHM,Xilinx,Pulse,ON,Everlight and Freescale. Main products comprise IC,Modules,Potentiometer,IC Socket,Relay,Connector.Our parts cover such applications as commercial,industrial, and automotives areas.

We are looking forward to setting up business relationship with you and hope to provide you with the best service and solution. Let us make a better world for our industry!



## Contact us

Tel: +86-755-8981 8866 Fax: +86-755-8427 6832

Email & Skype: info@chipsmall.com Web: www.chipsmall.com

Address: A1208, Overseas Decoration Building, #122 Zhenhua RD., Futian, Shenzhen, China



LOC	DIST	REVISIONS			
P	LTN	DESCRIPTION	DATE	DMN	APVD
GS	00	I	FIRST RELEASE	11OCT2012	OL SZ

- 1 MATERIAL: HOUSING: POLYESTER. COLOR: BLACK, UL 94 V-0  
CONTACT: COPPER ALLOY.
- 2 FINISH: CONTACT MATING AREA: 0.0076 mm MIN GOLD PLATE OVER 0.00127 mm MIN NICKEL, OR 0.0005 mm MIN GOLD OVER 0.00064 mm PALLADIUM-NICKEL OVER 0.00127 mm MIN NICKEL.  
COMPLIANT TAIL AREA: 0.0005 mm MIN BRIGHT TIN PLATE OVER 0.00127 mm NICKEL UNDERPLATE.
- 3 TAILS OF MATING UPM STYLE RECEPTACLE ARE OFFSET BY .75 mm FROM TAILS OF THIS CONNECTOR. SEE CUSTOMER DRAWING 120992 FOR RECEPTACLE EXAMPLE. SEE APPLICATION SPEC 114-1103 FOR MORE DETAILED DESCRIPTION OF THE TAIL OFFSETS.
- 4 PC BOARD HOLE SPECIFICATIONS:  
DRILLED HOLE SIZE: 0.700±0.02 mm  
FINISHED HOLE SIZE: 0.60±0.05 mm  
PLATING THICKNESS:  
0.025 - 0.050 mm COPPER  
0.004 - 0.010 mm HASL TIN  
0.0005 mm MIN IMMERSION TIN  
0.0002 - 0.0005 mm OSP  
0.0001mm MIN IMMERSION SILVER  
0.0001-0.0005 mm IMMERSION GOLD OVER 0.004-0.005 mm NICKEL
- 5 DATUM AND BASIC DIMENSIONS ESTABLISHED BY CUSTOMER.
- 6 MINIMUM REQUIRED PC BOARD THICKNESS IS 1.4mm.
- 7 CONTACT AREA LUBRICATED WITH BELLCORE APPROVED LUBRICANT. TECHNICAL REFERENCE GR-1217-CORE, ISSUE 1 NOVEMBER 1995.
- 8 POSITION A1 IS AT MATERIAL ID.

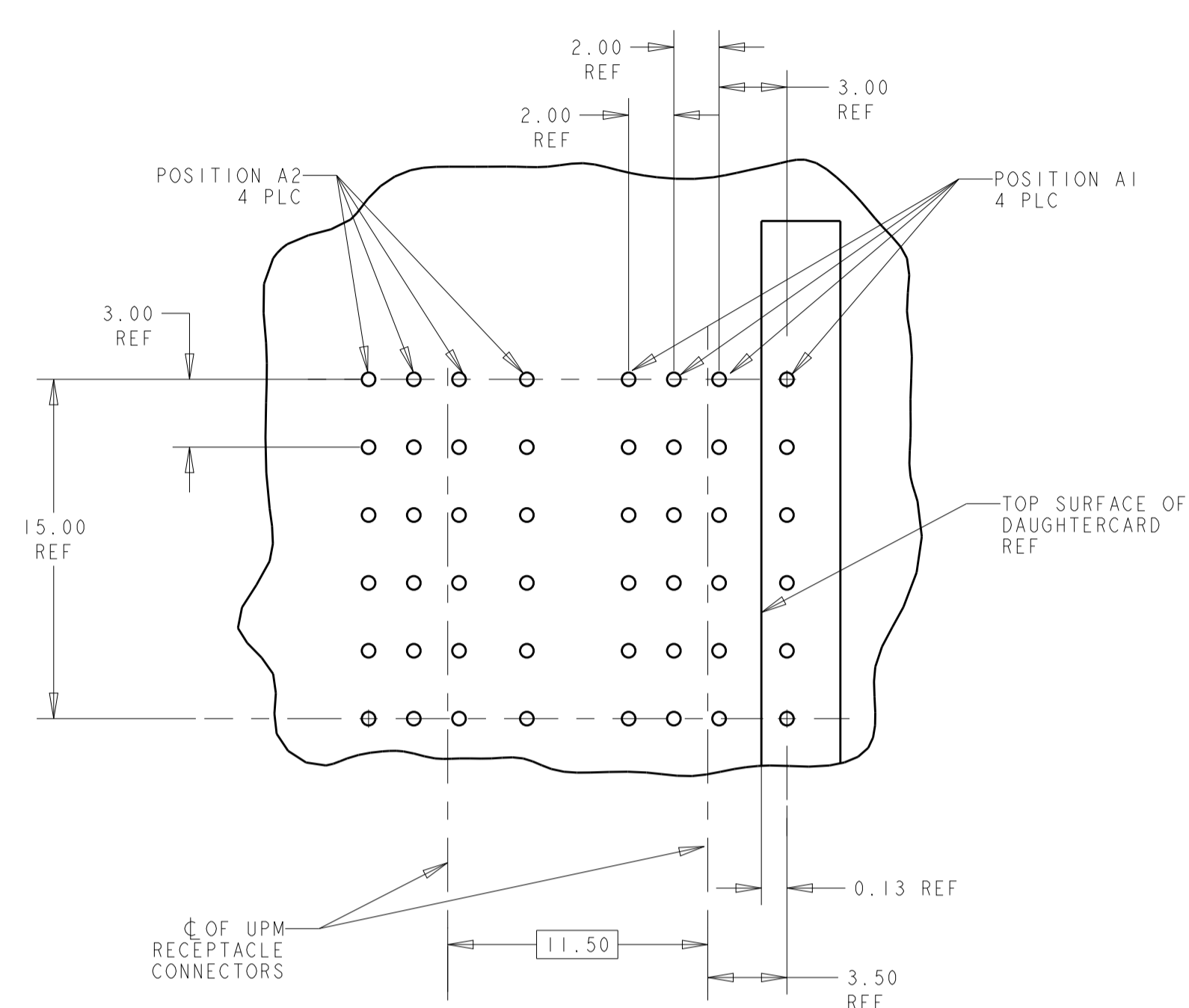

MATING RECEPTACLE PCB LAYOUT 3

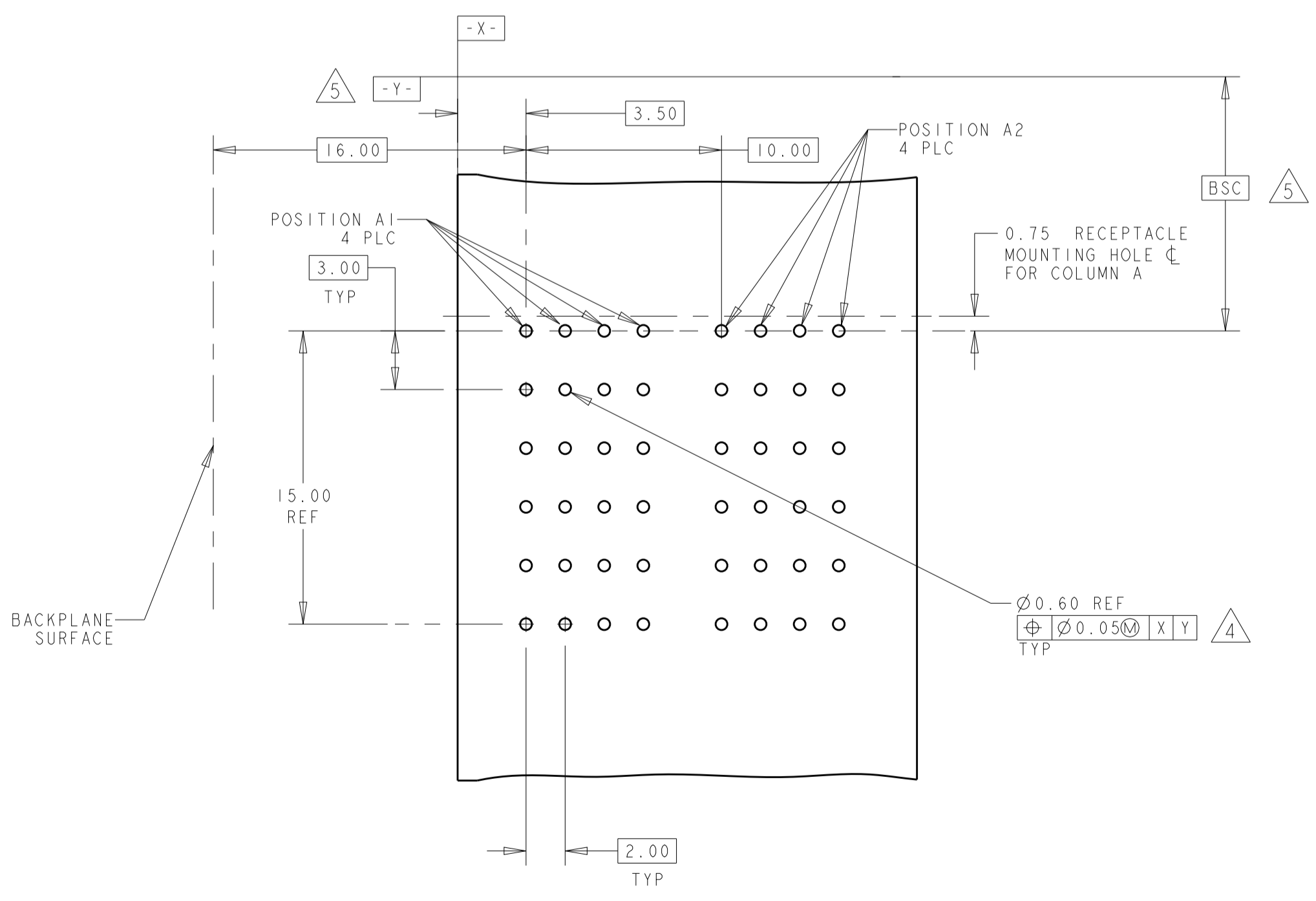
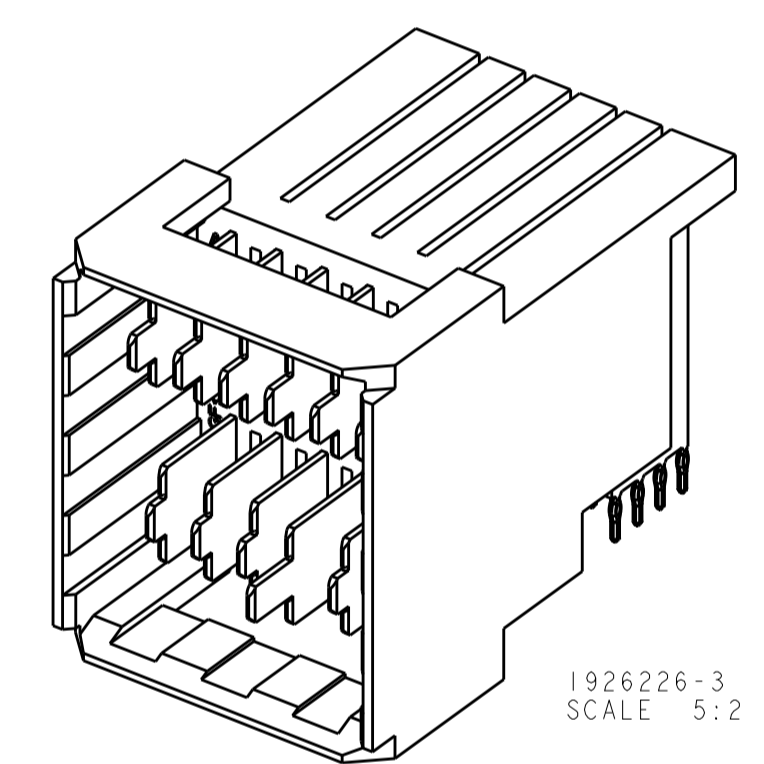
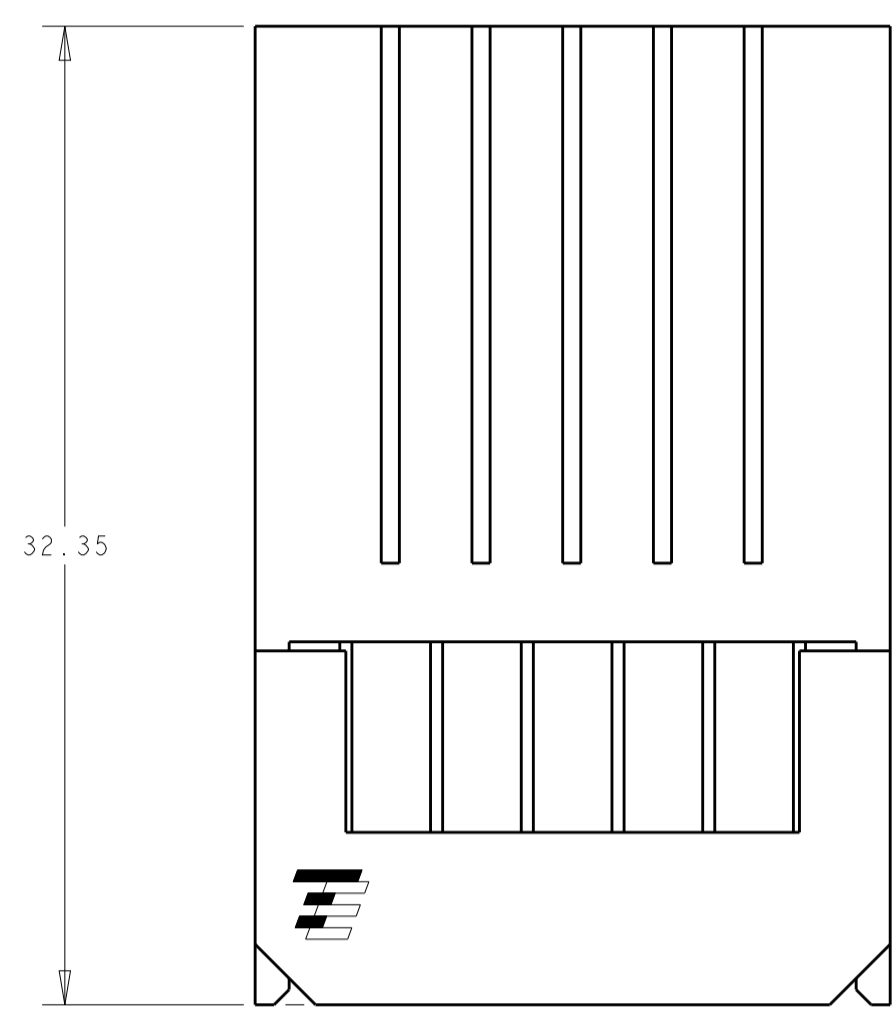

RECOMMENDED PCB LAYOUT 6

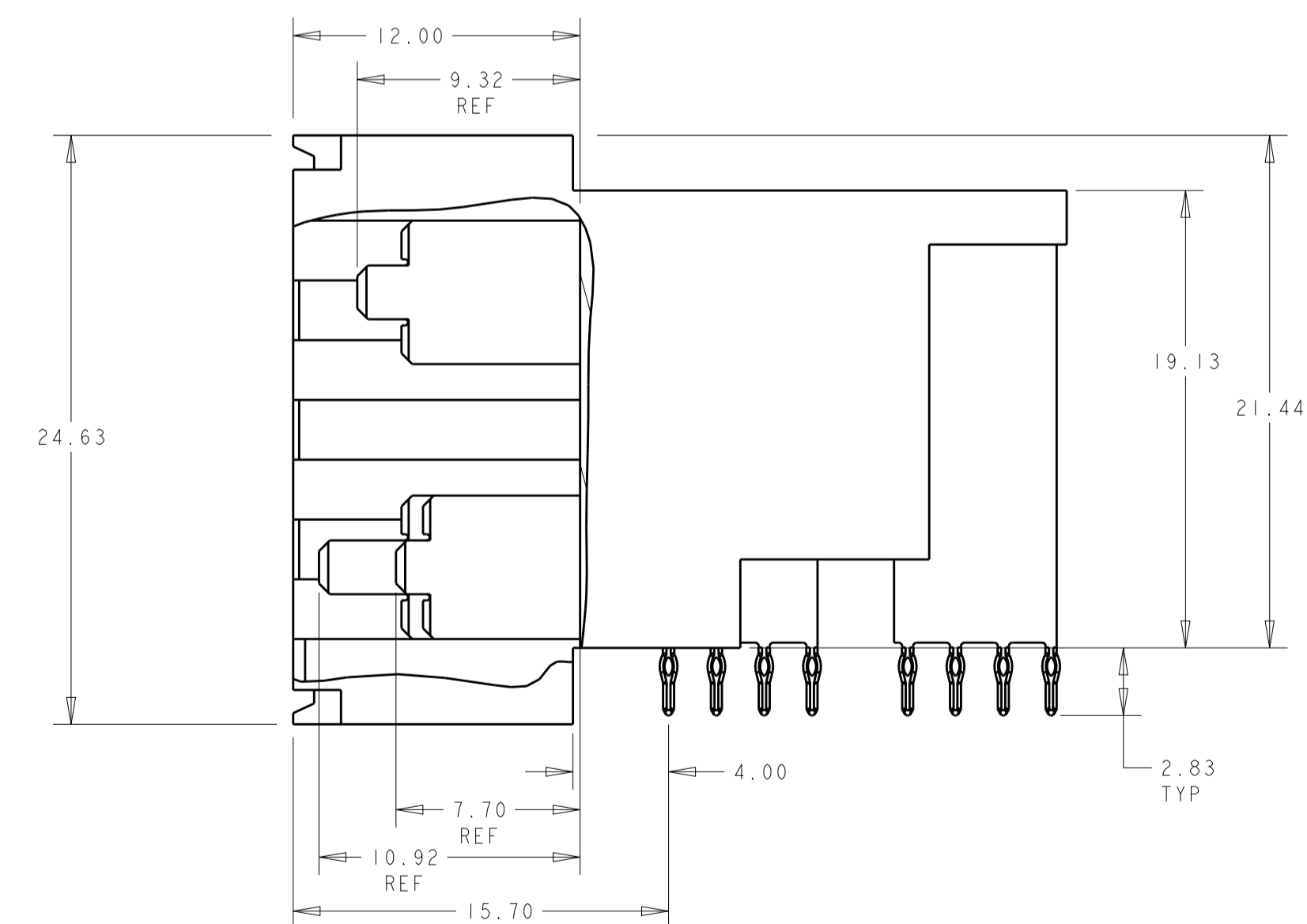
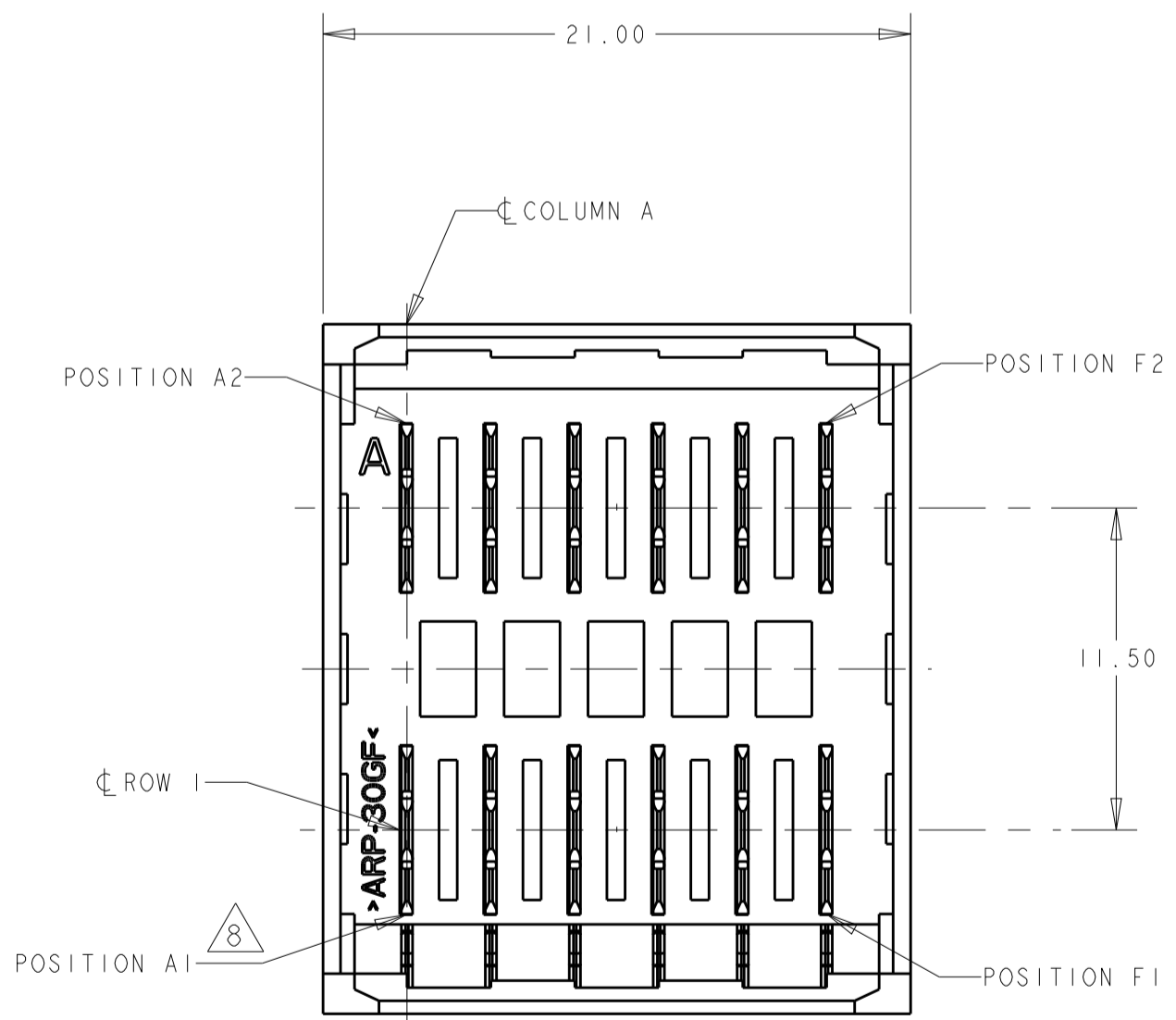

D1	A2,B2,C2,D2,E2,F2	A1,B1,C1,E1,F1	1892731-3
A1,B1,C1,D1,E1,F1	A2,B2,C2,D2,E2,F2	-	1892731-2
-	ALL	-	1892731-1
POSITIONS LOADED WITH LONG 10.92 REF CONTACTS	POSITIONS LOADED WITH MIDDLE 9.32 REF CONTACTS	POSITIONS LOADED WITH SHORT 7.70 REF CONTACTS	PART NO

DIMENSIONS: mm		TOLERANCES UNLESS OTHERWISE SPECIFIED:		DRN: ORANDO LL	11OCT2012	Tyco Electronics Harrisburg, PA 17105-3608
		0 PLC ±.25 1 PLC ±.25 2 PLC ±.25 3 PLC ±.25 4 PLC ±.25 ANGLES ±1°		CHK: SUNY ZHAO	11OCT2012	
MATERIAL: 1		FINISH: 2		PRODUCT SPEC: 108-2289	APPLICATION SPEC: 114-13269	<b>ASSEMBLY, RIGHT ANGLE CONNECTOR MINIPAK HDE 2X6 POSITION</b>
Customer Drawing		SCALE: 3:1		WEIGHT: -	SIZE: A100779	

THIS DRAWING IS UNPUBLISHED. RELEASED FOR PUBLICATION 20  
 COPYRIGHT 20 BY TYCO ELECTRONICS CORPORATION. ALL RIGHTS RESERVED.

LOC		DIST		REVISIONS				
P	LTN	DESCRIPTION	DATE	DWN	APVD			
-	-	SEE SHEET 1	-	-	-			

SEQUENCE LOADING PATTERNS VIEWED INTO MATING FACE OF CONNECTOR

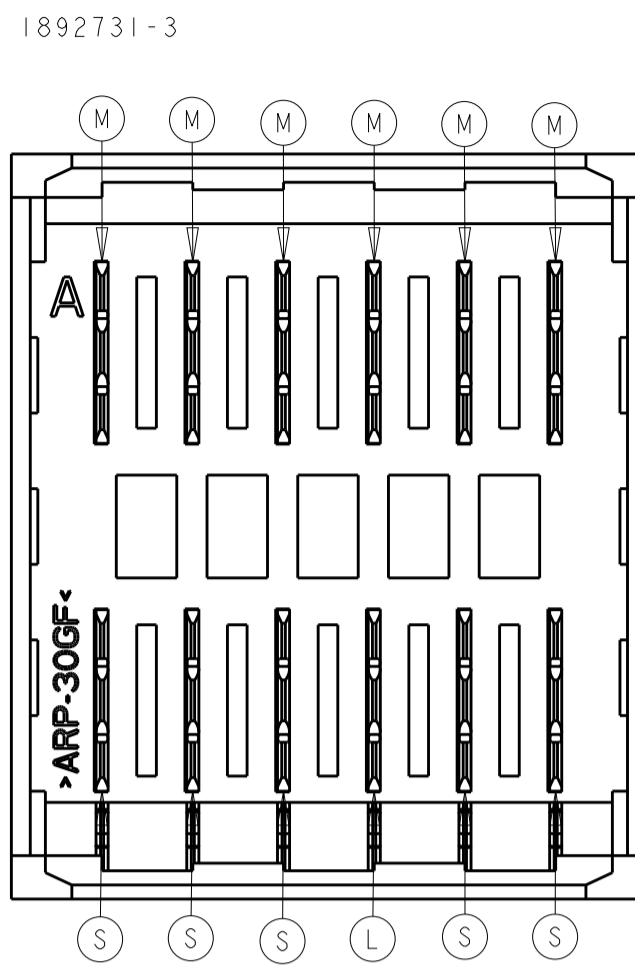
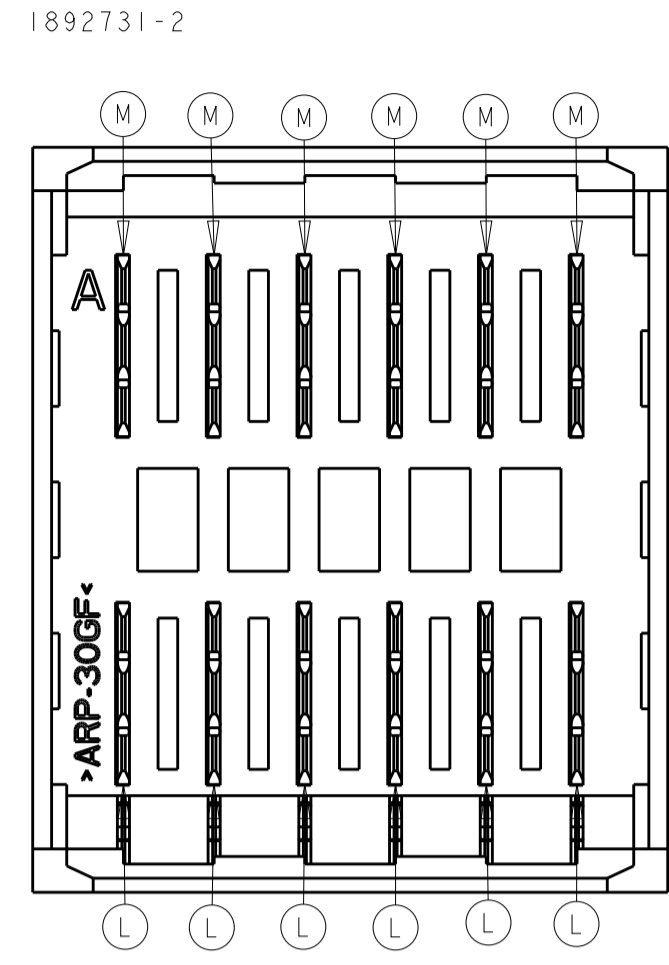
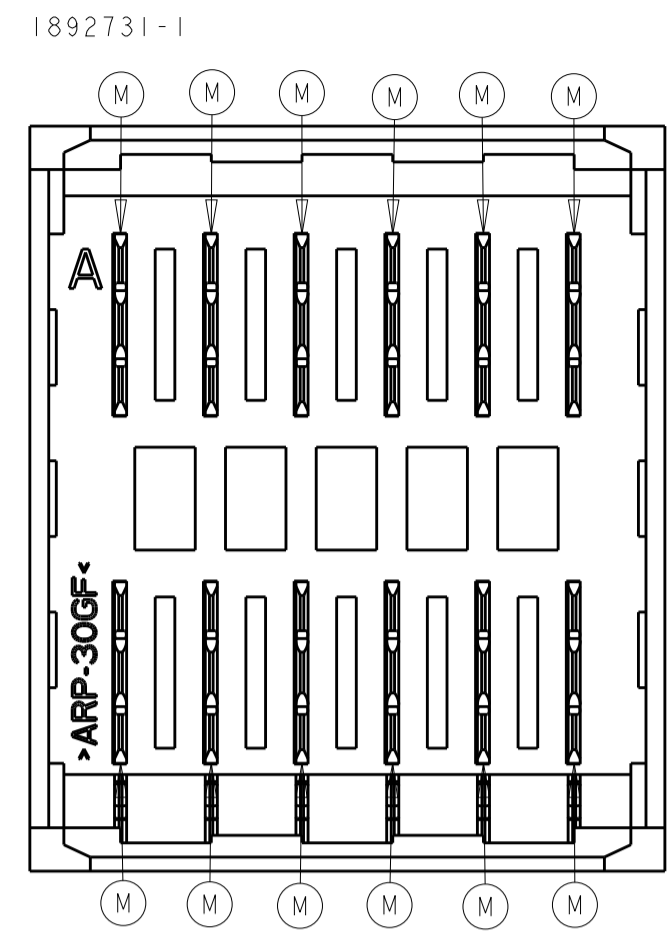

<small>THIS DRAWING IS UNPUBLISHED. RELEASED FOR PUBLICATION 20. THIS DRAWING IS UNPUBLISHED. RELEASED FOR PUBLICATION 20. THIS DRAWING IS UNPUBLISHED. RELEASED FOR PUBLICATION 20.</small>		DWN: <b>ORANDO LL</b> 17OCT2012 CHK: <b>OL</b> 17OCT2012 APVD: <b>SUNY ZHAO</b> 17OCT2012	Tyco Electronics Harrisburg, PA 17105-3608
DIMENSIONS: mm	TOLERANCES UNLESS OTHERWISE SPECIFIED: 0 PLC ±. 1 PLC ±.25 2 PLC ±.25 3 PLC ±. 4 PLC ±. ANGLES ±1°	NAME: <b>ASSEMBLY, RIGHT ANGLE CONNECTOR MINIPAK HDE 2X6 POSITION</b> PRODUCT SPEC: <b>108-2289</b> APPLICATION SPEC: <b>114-13269</b>	SIZE: <b>A</b>   CAGE CODE: <b>00779</b>   DRAWING NO: <b>1892731</b> RESTRICTED TO: <b>Customer Drawing</b>
MATERIAL: FINISH:	WEIGHT:	SCALE: <b>4:1</b>	SHEET: <b>2</b> OF <b>2</b>   REV: <b>1</b>