



Chipsmall Limited consists of a professional team with an average of over 10 year of expertise in the distribution of electronic components. Based in Hongkong, we have already established firm and mutual-benefit business relationships with customers from,Europe,America and south Asia,supplying obsolete and hard-to-find components to meet their specific needs.

With the principle of “Quality Parts,Customers Priority,Honest Operation,and Considerate Service”,our business mainly focus on the distribution of electronic components. Line cards we deal with include Microchip,ALPS,ROHM,Xilinx,Pulse,ON,Everlight and Freescale. Main products comprise IC,Modules,Potentiometer,IC Socket,Relay,Connector.Our parts cover such applications as commercial,industrial, and automotives areas.

We are looking forward to setting up business relationship with you and hope to provide you with the best service and solution. Let us make a better world for our industry!



Contact us

Tel: +86-755-8981 8866 Fax: +86-755-8427 6832

Email & Skype: info@chipsmall.com Web: www.chipsmall.com

Address: A1208, Overseas Decoration Building, #122 Zhenhua RD., Futian, Shenzhen, China





Description

The ICS1894-40 is a low-power, physical-layer device (PHY) that supports the ISO/IEC 10Base-T and 100Base-TX Carrier-Sense Multiple Access/Collision Detection (CSMA/CD) Ethernet standards, ISO/IEC 8802.3. It is intended for RMII/MII, Node/Repeater applications and includes the Auto-MDIX feature that automatically corrects crossover errors in plant wiring.

The ICS1894-40 incorporates Digital-Signal Processing (DSP) control in its Physical-Medium Dependent (PMD) sub-layer. As a result, it can transmit and receive data on unshielded twisted-pair (UTP) category 5 cables with attenuation in excess of 24 dB at 100MHz.

The ICS1894-40 provides a Serial-Management Interface for exchanging command and status information with a Station-Management (STA) entity. The ICS1894-40 Media-Dependent Interface (MDI) can be configured to provide either half-duplex or full-duplex operation at data rates of 10 Mb/s or 100Mb/s.

In addition, the ICS1894-40 includes a programmable LED and interrupt output function. The LED outputs can be configured through registers to indicate the occurrence of certain events such as LINK, COLLISION, ACTIVITY, etc. The purpose of the programmable interrupt output is to notify the PHY controller device immediately when a certain event happens instead of having the PHY controller continuously poll the PHY. The events that could be used to generate interrupts are: receiver error, Jabber, page received, parallel detect fault, link partner acknowledge, link status change, auto-negotiation complete, remote fault, collision, etc.

The ICS1894-40 has deep power modes that can result in significant power savings when the link is broken.

Applications: NIC cards, PC motherboards, switches, routers, DSL and cable modems, game machines, printers, network connected appliances, and industrial equipment.

Not recommended for new designs

— For full/half duplex RMII only interface support, please refer to ICS1894-43 datasheet.

— For full/half duplex MII only interface support, please refer to ICS1894-44 datasheet.

— ICS1894-43 and ICS1894-44 are pin-compatible with ICS1894-40.

Features

- Supports category 5 cables and above with attenuation in excess of 24dB at 100 MHz.
- Single-chip, fully integrated PHY provides PCS, PMA, PMD, and AUTONEG sub layers functions of IEEE standard.
- 10Base-T and 100Base-TX IEEE 8802.3 compliant
- MIIM (MDC/MDIO) management bus for PHY register configuration
- RMII interface support with external 50 MHz system clock
- Single 3.3V power supply
- Highly configurable, supports:
 - Media Independent Interface (MII)
 - Auto-Negotiation with Parallel detection
 - Node applications, managed or unmanaged
 - 10M or 100M full and half-duplex modes
 - Loopback mode for Diagnostic Functions
- Auto-MDI/MDIX crossover correction
- Low-power CMOS (typically 300 mW)
- Power-Down mode (typically 21mW)
- Clock and crystal supported in MII mode
- Programmable LEDs
- Interrupt output pin
- Fully integrated, DSP-based PMD includes:
 - Adaptive equalization and baseline-wander correction
 - Transmit wave shaping and stream cipher scrambler
 - MLT-3 encoder and NRZ/NRZI encoder
- Core power supply (3.3 V)
- 3.3 V/1.8 V VDDIO operation supported
- Smart power control with deep power down feature
- Available in 40-pin (6mm x 6mm) QFN package, Pb-free
- Industrial Temp and Lead Free

Block Diagram

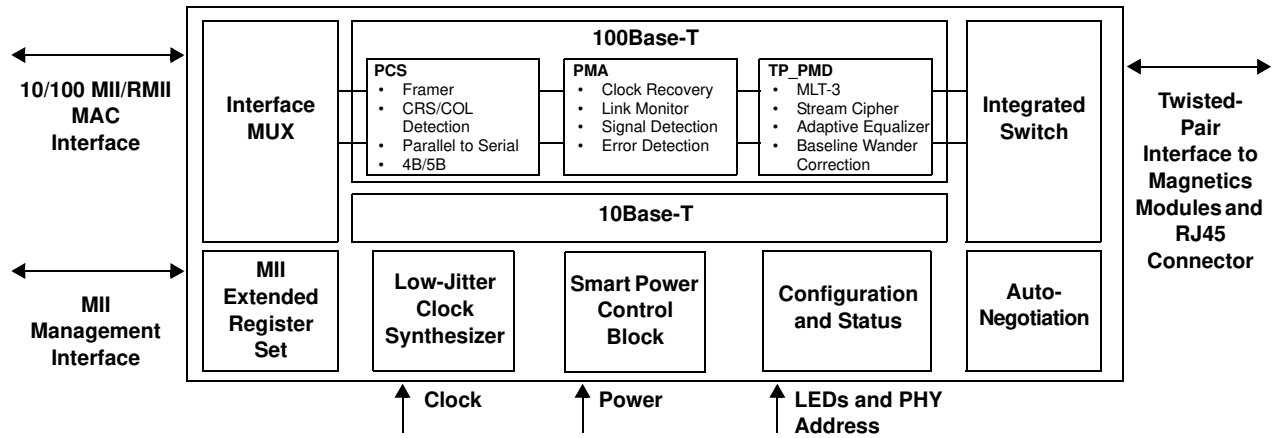

Pin Assignment

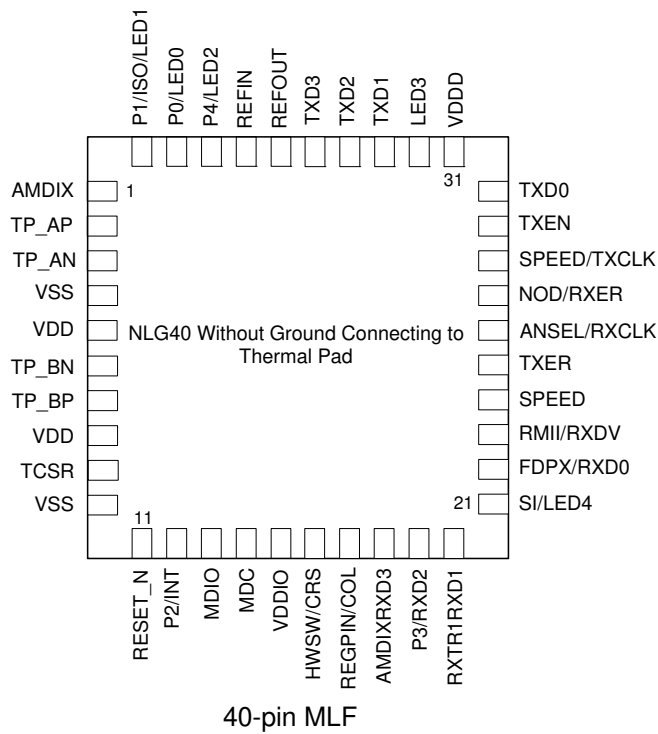

Pin Descriptions

Pin Number	Pin Name	Pin Type	Pin Description
1	AMDIX	IN/lpu	AMDIX Enable
2	TP_AP	AIO	Twisted pair port A (for either transmit or receive) positive signal
3	TP_AN	AIO	Twisted pair port A (for either transmit or receive) negative signal
4	VSS	Ground	Connect to ground.
5	VDD	Power	3.3V Power Supply
6	TP_BN	AIO	Twisted pair port B (for either transmit or receive) negative signal
7	TP_BP	AIO	Twisted pair port B (for either transmit or receive) positive signal
8	VDD	Power	3.3V Power Supply
9	TCSR	AIO	Transmit Current bias pin, connected to Vdd and ground via two resistors.
10	VSS	Ground	Connect to ground.
11	RESET_N	Input	Hardware reset for the whole chip (active low)
12	P2/INT	IO/lpd	PHY address Bit 2 as input (during power on reset and hardware reset) Interrupt output as output (default active low, can be programmed to active high)
13	MDIO	IO	Management Data Input/Output
14	MDC	Input	Management Data Clock
15	VDDIO	Power	3.3 V IO Power Supply.
16	HWSW/ CRS	IO/lpd	Hardware/Software control for phy speed as input (during power on reset and hardware reset) and CRS output in MII mode.
17	Regpin/ COL	IO/lpd	Full register access enable as input (during power on reset and hardware reset) and COL output in MII mode
18	AMDIX/RXD3	IO/lpu	AMDIX hardware enable as input (during power on reset and hardware reset) Receive data Bit 3 as output in MII mode
19	P3/RXD2	IO/lpd	PHY address Bit 3 as input (during power on reset and hardware reset) Receive data Bit 2 as output in MII mode
20	RXTRI/ RXD1	IO/lpd	RX isolate enable (during power on reset and hardware reset) Received data Bit 1 as output in both RMII and MII modes
21	SI/LED4	IO/lpd	MII/SI mode select as input (during power on reset and hardware reset) and LED #4 as output
22	FDPX/ RXD0	IO/lpu	Full duplex enable (during power on reset and hardware reset) Received data Bit 0 as output in both RMII and MII modes.
23	RMII/RXDV	IO/lpd	RMII/MII select as input (during power on reset and hardware reset) Receive data valid in MII mode and CRS_DV in RMII mode as output
24	SPEED	lpu	10/100M input select. 1 = 100M mode, 0 = 10M mode.
25	TXER	IN	TXER Input
26	ANSEL/ RXCLK9	IO/lpu	Auto-negotiation enable(during power on reset and hardware reset) Receive clock as output in MII mode
27	NOD/ RXER	IO/lpd	Node/repeater select (during power on reset and hardware reset) Receive error as output in MII mode

Pin Number	Pin Name	Pin Type	Pin Description
28	SPEED/ TXCLK	IO/Ipu	10M/100M select as input (during power on reset and hardware reset) Transmit clock as output in MII mode
29	TXEN	Input	Transmit enable for both RMII and MII modes
30	TXD0	Input	Transmit data Bit 0 for both RMII and MII modes
31	VDDD	Power	Core Power Supply
32	LED3	IO/Ipu	LED3 output
33	TXD1	Input	Transmit data Bit 1 for both RMII and MII modes
34	TXT2	Input	Transmit data Bit 2 for MII mode
35	TXD3	Input	Transmit data Bit 3 for MII mode
36	REF_OUT	Output	25 MHz crystal output
37	REF_IN	Input	25 MHz crystal (or clock) input for MII mode. 50MHz clock input for RMII mode
38	P4/LED2	IO/Ipu	PHY address Bit 4 as input (always latched high during power on reset and hardware reset) and LED # 2 as output
39	P0/LED0	IO	PHY address Bit 0 as input (during power on reset and hardware reset) and LED # 0(function configurable, default is "activity/no activity") as output
40	P1/ISO/LED1	IO	PHY address Bit 1 as input (during power on reset and hardware reset) and LED # 1 (function configurable, default is "10/100 mode") as output

Notes:

- AIO: Analog input/output PAD.
IO: Digital input/output.
IN/Ipu: Digital input with internal 20k pull-up.
IN/Ipd: Digital input with internal 20k pull-down.
IO/Ipu: Digital input/output with internal 20k pull-up.
IO/Ipd: Digital input/output with internal 20k pull-down.
- MII Rx Mode: The RXD[3..0] bits are synchronous with RXCLK. When RXDV is asserted, RXD[3..0] presents valid data to MAC on the MII interface. RXD[3..0] is invalid when RXDV is de-asserted.
- RMII Rx Mode: The RXD[1:0] bits are synchronous with REFIN. For each clock period in which CRS_DV is asserted, two bits of recovered data are sent from the PHY to the MAC.
- MII Tx Mode: The TXD[3..0] bits are synchronous with TXCLK. When TXEN is asserted, TXD[3..0] presents valid data from the MAC on the MII interface. TXD[3..0] has no effect when TXEN is de-asserted.
- RMII Tx Mode: The TXD[1:0] bits are synchronous with REFIN. For each clock period in which TX_EN is asserted, two bits of data are received by the PHY from the MAC.

Strapping Options

Pin Number	Pin Name	Pin Type ¹	Pin Function
1	AMDIX	IN/lpu	1 = AMDIX enable 0 = AMDIX disable
16	HWSW/CRS	IO/lpd	Hardware pin select enable. Active during power-on and hardware reset.
17	REGPIN/COL	IO/lpd	Full register access enable. Active during power-on and hardware reset.
18	AMDIX/RXD2	IO/lpu	1 = AMDIX enable 0 = AMDIX disable
38	P4/LED2	IO/lpu	The PHY address is set by P[4:0] at power-on reset. P0 and P1 must have external pull-up or pull-down to set address at start up.
19	P3/RXD2	IO/lpd	
12	P2/INT	IO/lpd	
40	P1/ISO/LED1	IO/	
39	P0/LED0	IO/	
21	SI/LED4	IO/lpd	MII/SI mode select. Active during power-on and hardware reset.
20	RXTRI/RXD1	IO/lpd	1=Realtime receiver isolation enable ³ ; 0=RX output enable
22	FDPX/RXD0	IO/lpu	1=Full duplex 0=Half duplex Ignored if Auto negotiation is enabled
23	RMII/RXDV	IO/lpd	[1x]=RMII mode [01]=SI mode (Serial interface mode) [00]=MII mode
24	SPEED	IO/lpu	1=100M mode 0=10M mode
26	ANSEL/RXCLK	IO/lpu	1=Enable auto negotiation 0=Disable auto negotiation
27	NOD/RXER	IO/lpd	0=Node mode 1=repeater mode
28	SPEED/TXCLK	IO/lpu	1=100M mode 0=10M mode Ignored if Auto negotiation is enabled
32	LED3	IO/lpu	LED3 output

1. IO/lpu = Digital Input with internal 20k pull-up during power on reset/hardware reset; output pin otherwise.
2. IO/lpd = Digital Input with internal 20k pull-down during power on reset/hardware reset; output pin otherwise.
3. If RXTRI/RXD1 pin is latched high during power on reset/hardware reset, P1/ISO/LED1 functions as RX real time isolation control input after latch and LED1 function will be disabled.

Functional Description

The ICS1894-40 is an ethernet PHYceiver. During data transmission, it accepts sequential nibbles/di-bits from the MAC (Media Access Control), converts them into a serial bit stream, encodes them, and transmits them over the medium

through an external isolation transformer. When receiving data, the ICS1894-40 converts and decodes a serial bit stream (acquired from an isolation transformer that interfaces with the medium) into sequential nibbles/di-bits. It subsequently presents these nibbles/di-bits to the MAC Interface.

The ICS1894-40 implements the OSI model's physical layer, consisting of the following, as defined by the ISO/IEC 8802-3 standard:

- Physical Coding sublayer (PCS)
- Physical Medium Attachment sublayer (PMA)
- Physical Medium Dependent sublayer (PMD)
- Auto-Negotiation sublayer

The ICS1894-40 is transparent to the next layer of the OSI model, the link layer. The link layer has two sublayers: the Logical Link Control sublayer and the MAC sublayer. The ICS1894-40 can interface directly with the MAC via MII/RMII interface signals.

The ICS1894-40 transmits framed packets acquired from its MAC Interface and receives encapsulated packets from another PHY, which it translates and presents to its MAC Interface.

Note: As per the ISO/IEC standard, the ICS1894-40 does not affect, nor is it affected by, the underlying structure of the MAC frame it is conveying.

100Base-TX Operation

During 100Base-TX data transmission, the ICS1894-40 accepts packets from the MAC and inserts Start-of-Stream Delimiters (SSDs) and End-of-Stream Delimiters (ESDs) into the data stream. The ICS1894-40 encapsulates each MAC frame, including the preamble, with an SSD and an ESD. As per the ISO/IEC Standard, the ICS1894-40 replaces the first octet of each MAC preamble with an SSD and appends an ESD to the end of each MAC frame.

When receiving data from the medium, the ICS1894-40 removes each SSD and replaces it with the pre-defined preamble pattern before presenting the data on the MAC Interface. When the ICS1894-40 encounters an ESD in the received data stream, signifying the end of the frame, it ends the presentation of data on the MAC Interface. Therefore, the local MAC receives an unaltered copy of the transmitted frame sent by the remote MAC.

During periods when MAC frames are being neither transmitted nor received, the ICS1894-40 signals and detects the IDLE condition on the Link Segment. In the 100Base-TX mode, the ICS1894-40 transmit channel sends a continuous stream of scrambled ones to signify the IDLE

condition. Similarly, the ICS1894-40 receive channel continually monitors its data stream and looks for a pattern of scrambled ones. The results of this signaling and monitoring provide the ICS1894-40 with the means to establish the integrity of the Link Segment between itself and its remote link partner and inform its Station Management Entity (SME) of the link status.

10Base-T Operation

During 10Base-T data transmission, the ICS1894-40 inserts only the IDL delimiter into the data stream. The ICS1894-40 appends the IDL delimiter to the end of each MAC frame. However, since the 10Base-T preamble already has a Start-of-Frame delimiter (SFD), it is not required that the ICS1894-40 insert an SSD-like delimiter.

When receiving data from the medium (such as a twisted-pair cable), the ICS1894-40 uses the preamble to synchronize its receive clock. When the ICS1894-40 receive clock establishes lock, it presents the preamble nibbles to the MAC Interface.

In 10M operations, during periods when MAC frames are being neither transmitted nor received, the ICS1894-40 signals and detects Normal Link Pulses. This action allows the integrity of the Link Segment with the remote link partner to be established and then reported to the ICS1894-40's SME.

Auto-Negotiation

The ICS1894-40 conforms to the auto-negotiation protocol, defined in Clause 28 of the IEEE 802.3u specification. Autonegotiation is enabled by either hardware pin strapping (pin 20) or software (register 0h bit 12).

Auto-negotiation allows link partners to select the highest common mode of operation. Link partners advertise their capabilities to each other, and then compare their own capabilities with those they received from their link partners. The highest speed and duplex setting that is common to the two link partners is selected as the mode of operation.

The following list shows the speed and duplex operation mode from highest to lowest.

- Priority 1: 100Base-TX, full-duplex
- Priority 2: 100Base-TX, half-duplex
- Priority 3: 10Base-T, full-duplex
- Priority 4: 10Base-T, half-duplex

If auto-negotiation is not supported or the ICS1894-40 link partner is forced to bypass auto-negotiation, the ICS1894-40 sets its operating mode by observing the signal at its receiver. This is known as parallel detection, and allows the ICS1894-40 to establish link by listening for a fixed signal protocol in the absence of auto-negotiation advertisement protocol.

MII Management (MIIM) Interface

The ICS1894-40 supports the IEEE 802.3 MII Management Interface, also known as the Management Data Input / Output (MDIO) Interface. This interface allows upper-layer devices to monitor and control the state of the ICS1894-40. An external device with MIIM capability is used to read the PHY status and/or configure the PHY settings. Additional details on the MIIM interface can be found in Clause 22.2.4.5 of the IEEE 802.3u Specification.

The MIIM interface consists of the following:

MII Management Frame Format

	Preamble	Start of Frame	Read/Write OP Code	PHY Address Bits [4:0]	REG Address Bits [4:0]	TA	Data Bits [15:0]	Idle
Read	32 1's	01	10	1AAAA	RRRRR	Z0	DDDDDDDD_DDDDDDDD	Z
Write	32 1's	01	01	00AAA	RRRRR	10	DDDDDDDD_DDDDDDDD	Z

Interrupt (INT)

P2/INT (pin 12) is an optional interrupt signal that is used to inform the external controller that there has been a status update in the ICS1894-40 PHY register. Register 23 shows the status of the various interrupts while register 22 controls the enabling/disabling of the interrupts.

MII Data Interface

The Media Independent Interface (MII) is specified in Clause 22 of the IEEE 802.3u Specification. It provides a common interface between physical layer and MAC layer devices, and has the following key characteristics:

- Supports 10Mbps and 100Mbps data rates.
- Uses a 25MHz reference clock, sourced by the PHY.
- Provides independent 4-bit wide (nibble) transmit and receive data paths.
- Contains two distinct groups of signals: one for transmission and the other for reception.

The ICS1894-40 is configured for MII mode upon power-up

- A physical connection that incorporates the clock line (MDC) and the data line (MDIO).
- A specific protocol that operates across the aforementioned physical connection that allows an external controller to communicate with one or more ICS1894-40 devices. Each ICS1894-40 device is assigned a PHY address that is set by the P[4:0] strapping pins
- An internal addressable set of thirty-one 8-bit MDIO registers. Register [0:6] are required, and their functions are defined by the IEEE 802.3u Specification. The additional registers are provided for expanded functionality.

The ICS1894-40 supports MIIM in both MII mode and RMII mode.

The following table shows the MII Management frame format for the ICS1894-40.

or hardware reset with the following:

- A 25MHz crystal connected to REFIN, REFOUT (pins 7, 36), or an external 25MHz clock source (oscillator) connected to REFIN

MII Signal Definition

The following table describes the MII signals. Refer to Clause 22 of the IEEE 802.3u Specification for detailed information.

MII Signal Name	Direction (with respect to PHY, ICS1894-40 signal)	Direction (with respect to MAC)	Description
TXCLK	Output	Input	Transmit Clock (2.5MHz for 10Mbps; 25MHz for 100Mbps)
TXEN	Input	Output	Transmit Enable
TXD[3:0]	Input	Output	Transmit Data [3:0]
RXCLK	Output	Input	Receive Clock (2.5MHz for 10Mbps; 25MHz for 100Mbps)
RXDV	Output	Input	Receive Data Valid
RXD[3:0]	Output	Input	Receive Data [3:0]
RXER	Output	Input, or (not required)	Receive Error
CRS	Output	Input	Carrier Sense
COL	Output	Input	Collision Detection

Transmit Clock (TXCLK)

TXCLK is sourced by the PHY. It is a continuous clock that provides the timing reference for TXEN and TXD[3:0]. TXCLK is 2.5MHz for 10Mbps operation and 25MHz for 100Mbps operation.

Transmit Enable (TXEN)

TXEN indicates the MAC is presenting nibbles on TXD[3:0] for transmission. It is asserted synchronously with the first nibble of the preamble and remains asserted while all nibbles to be transmitted are presented on the MII, and is negated prior to the first TXCLK following the final nibble of a frame. TXEN transitions synchronously with respect to TXCLK.

Transmit Data (TXD[3:0])

TXD[3:0] transitions synchronously with respect to TXCLK. When TXEN is asserted, TXD[3:0] are accepted for transmission by the PHY. TXD[3:0] is "00" to indicate idle when TXEN is de-asserted. Values other than "00" on TXD[3:0] while TXEN is de-asserted are ignored by the PHY.

Receive Clock (RXCLK)

RXCLK provides the timing reference for RXDV, RXD[3:0], and RXER.

- In 10Mbps mode, RXCLK is recovered from the line while carrier is active. RXCLK is derived from the PHY's reference clock when the line is idle, or link is down.
- In 100Mbps mode, RXCLK is continuously recovered from the line. If link is down, RXCLK is derived from the PHY's reference clock.

RXCLK is 2.5MHz for 10Mbps operation and 25MHz for 100Mbps operation.

Receive Data Valid (RXDV)

RXDV is driven by the PHY to indicate that the PHY is presenting recovered and decoded nibbles on RXD[3:0].

- In 10Mbps mode, RXDV is asserted with the first nibble of the SFD (Start of Frame Delimiter), and remains asserted until the end of the frame.
- In 100Mbps mode, RXDV is asserted from the first nibble of the preamble to the last nibble of the frame.

RXDV transitions synchronously with respect to RXCLK.

Receive Data (RXD[3:0])

RXD[3:0] transitions synchronously with respect to RXC. For each clock period in which RXDV is asserted, RXD[3:0] transfers a nibble of recovered data from the PHY.

Receive Error (RXER)

RXER is asserted for one or more RXCLK periods to indicate that an error (e.g. a coding error or any error that a PHY is capable of detecting, and that may otherwise be undetectable by the MAC sub-layer) was detected somewhere in the frame presently being transferred from the PHY. RXER transitions synchronously with respect to RXC. While RXDV is de-asserted, RXER has no effect on the MAC.

Carrier Sense (CRS)

CRS is asserted and de-asserted as follows:

- In 10Mbps mode, CRS assertion is based on the reception of valid preambles. CRS de-assertion is based on the reception of an end-of-frame (EOF) marker.
- In 100Mbps mode, CRS is asserted when a start-of-stream delimiter, or /J/K symbol pair is detected. CRS is deasserted when an end-of-stream delimiter, or /T/R symbol pair is detected. Additionally, the PMA layer de-asserts CRS if IDLE symbols are received without /T/R.

Collision (COL)

COL is asserted in half-duplex mode whenever the transmitter and receiver are simultaneously active on the line. This is used to inform the MAC that a collision has occurred during its transmission to the PHY.

COL transitions asynchronously with respect to TXCLK and RXCLK.

Reduced MII (RMII) Data Interface

The Reduced Media Independent Interface (RMII) specifies a low pin count Media Independent Interface (MII). It provides a common interface between physical layer and MAC layer devices, and has the following key characteristics:

- Supports 10Mbps and 100Mbps data rates.
- Uses a single 50MHz reference clock provided by the MAC or the system board.
- Provides independent 2-bit wide (di-bit) transmit and receive data paths.
- Contains two distinct groups of signals: one for transmission and the other for reception.

In RMII mode, a 50 MHz reference clock is connected to REFIN(pin 30).

RMII Signal Definition

The following table describes the RMII signals. Refer to RMII Specification for detailed information.

RMII Signal Name	Direction (with respect to PHY, ICS1894-40 signal)	Direction (with respect to MAC)	Description
REFIN	Input	Input or Output	Synchronous 50 MHz clock reference for receive, transmit and control interface
TX_EN	Input	Output	Transmit Enable
TXD[1:0]	Input	Output	Transmit Data [1:0]
RXD[1:0]	Output	Input	Receive Data [1:0]
RX_ER	Output	Input, or (not required)	Receive Error
CRS_DV[RXDV]	Output	Input	Carrier Sense/Data Valid

Reference Clock (REFIN)

REFIN is sourced by the MAC or system board. It is a continuous 50MHz clock that provides the timing reference for TX_EN, TXD[1:0], CRS_DV, RXD[1:0], and RX_ER.

Transmit Enable (TX_EN)

TX_EN indicates that the MAC is presenting di-bits on TXD[1:0] for transmission. It is asserted synchronously with the first nibble of the preamble and remains asserted while all di-bits to be transmitted are presented on the RMII, and is negated prior to the first REFIN following the final di-bit of a frame. TX_EN transitions synchronously with respect to REFIN.

Transmit Data [1:0] (TXD[1:0])

TXD[1:0] transitions synchronously with respect to REFIN. When TX_EN is asserted, TXD[1:0] are accepted for transmission by the PHY. TXD[1:0] is "00" to indicate idle when TX_EN is de-asserted. Values other than "00" on TXD[1:0] while TX_EN is de-asserted are ignored by the PHY.

Carrier Sense/Data Valid (CRS_DV[RXDV])

CRS_DV, identified as RXDV (pin 23), shall be asserted by the PHY when the receive medium is non-idle. The specifics of the definition of idle for 10BASE-T and 100BASE-X are contained in IEEE 802.3 [1] and IEEE 802.3u [2]. CRS_DV is asserted asynchronously on detection of carrier due to the criteria relevant to the operating mode. That is, in 10BASE-T mode, when squelch is passed or in 100BASE-X mode when 2 non-contiguous zeroes in 10 bits are detected carrier is said to be detected.

Loss of carrier shall result in the deassertion of CRS_DV synchronous to the cycle of REFIN which presents the first di-bit of a nibble onto RXD[1:0] (i.e. CRS_DV is deasserted only on nibble boundaries). If the PHY has additional bits to be presented on RXD[1:0] following the initial deassertion of CRS_DV, then the PHY shall assert CRS_DV on cycles of REFIN which present the second di-bit of each nibble and deassert CRS_DV on cycles of REFIN which present the first di-bit of a nibble. The result is: Starting on nibble boundaries CRS_DV toggles at 25 MHz in 100Mb/s mode and 2.5 MHz in 10Mb/s mode when the Carrier event ends before the RX_DV signal internal to the PHY is deasserted (i.e. the FIFO still has bits to transfer when the carrier event ends.) Therefore, the MAC can accurately recover RX_DV and the Carrier event end time. During a false carrier event, CRS_DV shall remain asserted for the duration of carrier activity.

The data on RXD[1:0] is considered valid once CRS_DV is asserted. However, since the assertion of CRS_DV is asynchronous relative to REFIN, the data on RXD[1:0] shall be "00" until proper receive signal decoding takes place (see definition of RXD[1:0] behavior).

***Note:** CRS_DV is asserted asynchronously in order to minimize latency of control signals through the PHY.

Receive Data [1:0] (RXD[1:0])

RXD[1:0] transitions synchronously to REFIN. For each clock period in which CRS_DV is asserted, RXD[1:0] transfers two bits of recovered data from the PHY. RXD[1:0] is "00" to indicate idle when CRS_DV is de-asserted. Values other than "00" on RXD[1:0] while CRS_DV is de-asserted are ignored by the MAC.

Receive Error (RX_ER)

RX_ER is asserted for one or more REFIN periods to indicate that an error (e.g. a coding error or any error that a PHY is capable of detecting, and that may otherwise be undetectable by the MAC sub-layer) was detected somewhere in the frame presently being transferred from the PHY. RX_ER transitions synchronously with respect to REFIN. While CRS_DV is de-asserted, RX_ER has no effect on the MAC.

AMDIX_EN (Pin 18) AMDIX enable pin with 20 kOhm pull-up resistor

AMDIX_EN [19:9] MDIO register 19h bit 9

MDI_MODE [19:8] MDIO register 19h bit 8

Auto-MDI/MDIX Crossover

The ICS1894-40 includes the auto-MDI/MDIX crossover feature. In a typical CAT 5 Ethernet installation the transmit twisted pair signal pins of the RJ45 connector are crossed over in the CAT 5 wiring to the partners receive twisted pair signal pins and receive twisted pair to the partners transmit twisted pair. This is usually accomplished in the wiring plant. Hubs generally wire the RJ45 connector crossed to accomplish the crossover. Two types of CAT 5 cables (straight and crossed) are available to achieve the correct connection. The Auto-MDI/MDIX feature automatically corrects for miss-wired installations by automatically swapping transmit and receive signal pairs at the PHY when no link results. Auto-MDI/MDIX is automatic, but may be disabled for test purposes by writing MDIO register 19 Bits 9:8 in the MDIO register. The Auto-MDI/MDIX function is independent of Auto-Negotiation and precedes Auto-Negotiation when enabled.

Auto MDI/MDIX Table

AMDIX_EN (pin 18)	AMDIX_EN [Reg 19:9]	MDI_MODE [Reg 19:8]	Tx/Rx MDI Configuration
x	0	0	straight
x	0	1	cross
0	1	x	straight
1	1	x	straight/cross (auto select)
Default			
1	1	0	straight/cross (auto select)

Definitions:

straight transmit = TP_AP & TP_AN
receive = TP_BP & TP_BN

cross transmit = TP_BP & TP_BN
receive = TP_AP & TP_AN

Power Management

The ICS1894-40 supports a Deep Power Mode (DPD) that is enabled under the following conditions:

1. The Phy is not Receiving any signal from the partner (Link Down)
2. The MAC is not transmitting data to the Phy (TXEN Low)

Once the above conditions are met, the Phy goes into DPD mode after 32s (typical).

The logic internal to the device can be selectively shut down in DPD mode depending on Register 24 Bits 8-4.

Block Diagram of the Different Sections of the PHY as Affected by Register 24 bits

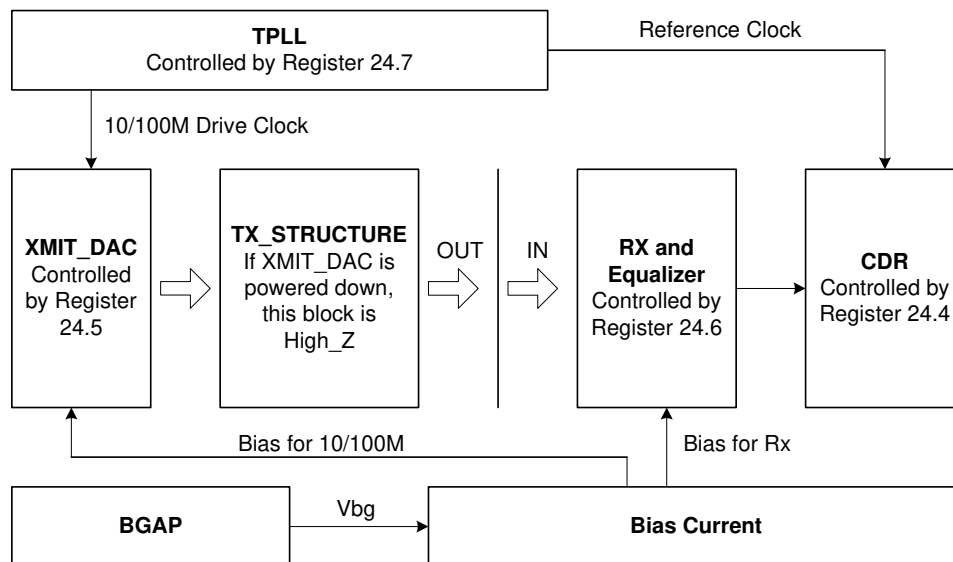

Clock Reference Interface

The REFIN pin provides the ICS1894-40 Clock Reference Interface. The ICS1894-40 requires a single clock reference with a frequency of 25 MHz \pm 50 parts per million. This accuracy is necessary to meet the interface requirements of the ISO/IEEE 8802-3 standard, specifically clauses 22.2.2.1 and 24.2.3.4. The ICS1894-40 supports two clock source configurations: a CMOS oscillator or a CMOS driver. The input to REFIN is CMOS (10% to 90% VDD), not TTL. Alternately, a 25MHz crystal may be used.

Crystal or Oscillator Connection

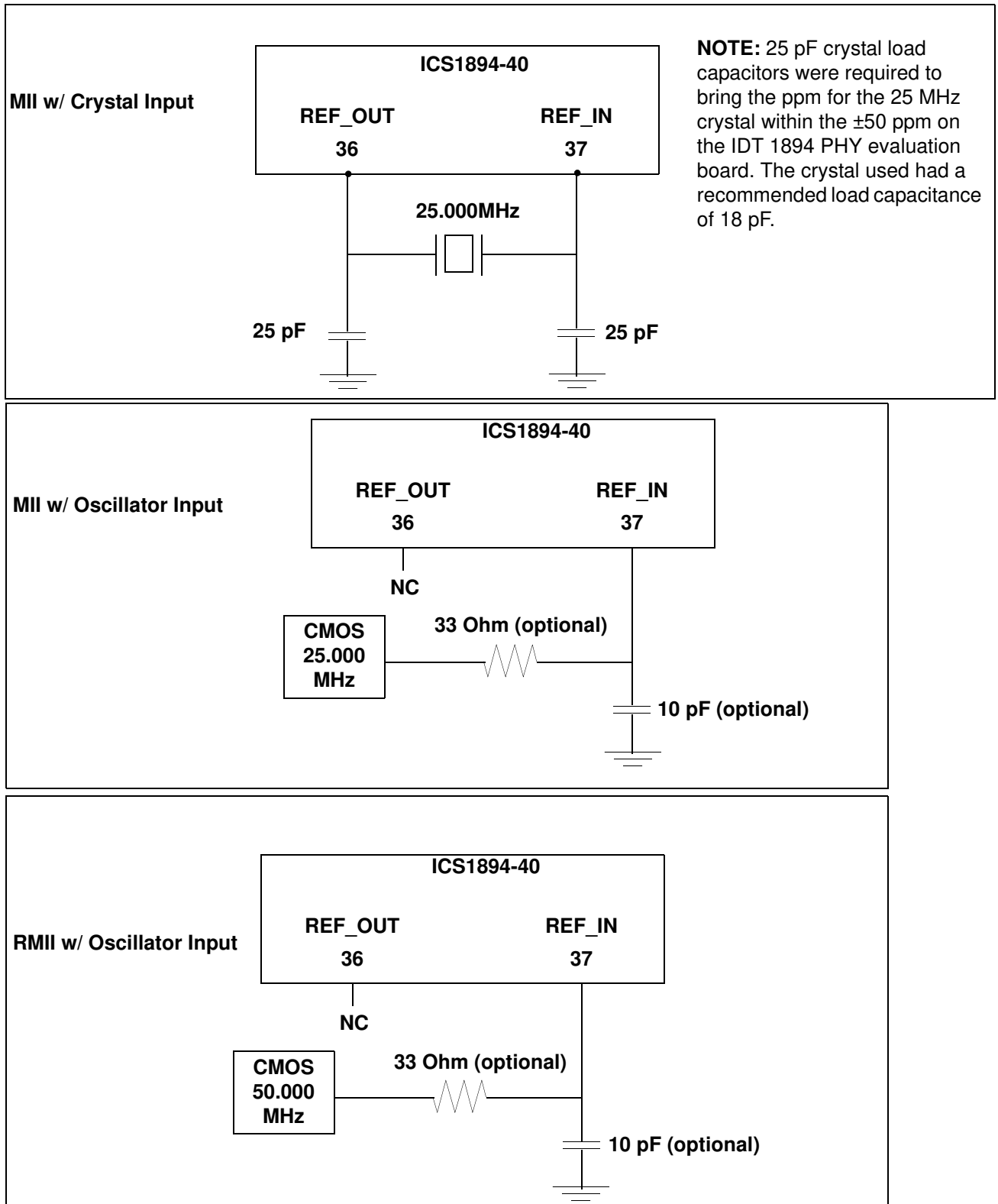

If a crystal is used as the clocking source, connect it to both the REF_IN (pin 37) and REF_OUT (pin 36) pins of the ICS1894-40. A pair of bypass capacitors on either side of the crystal are connected to ground. The crystal is used in the parallel resonance or anti-resonance mode. The value of the load caps serve to adjust the final frequency of the crystal oscillation. Typical applications would use 25 pF load caps. The exact value will be affected by the board routing capacitance on REF_IN and REF_OUT pins. Smaller load capacitors raise the frequency of oscillation.

Once the exact value of load capacitance is established it will be the same for all boards using the same specification crystal. The best way to measure the crystal frequency is to measure the frequency of TXCLK (pin 28) using a frequency counter with a 1 second gate time. Using the buffered output TXCLK prevents the crystal frequency from being affected by the measurement. The crystal specification is shown in the *25MHz Crystal Specification* table.

25 MHz Crystal Specification Table

Specifications	Symbol	Minimum	Typical	Maximum	Unit
Fundamental Frequency	F0	24.99875	25.00000	25.00125	MHz
Freq. Tolerance	$\Delta F/f$			± 50	ppm
Input Capacitance	Cin		3		pF

25 MHz Oscillator Specification table

Specifications	Symbol	Minimum	Typical	Maximum	Unit
Output Frequency	F0	24.99875	25.00000	25.00125	MHz
Freq. Stability (including aging)	$\Delta F/f$			± 50	ppm
Duty cycle CMOS level one-half VDD	Tw/T	35		65	%
VIH		2.79			Volts
VIL				0.33	Volts

50 MHz Oscillator Specification table

Specifications	Symbol	Minimum	Typical	Maximum	Unit
Output Frequency	F0	49.9975	50.00000	50.0025	MHz
Freq. Stability (including aging)	$\Delta F/f$			± 50	ppm
Duty cycle CMOS level one-half VDD	Tw/T	35		65	%
VIH		2.79			Volts
VIL				0.33	Volts

Status Interface

The ICS1894-40 has five multi-function configuration pins that report the PHY status by providing signals that are intended for driving LEDs. Configuration is set by Bank0 Register 20.

Pins for Monitoring the Data Link table

Pin	LED Driven by the Pin's Output Signal
P0/LED0	Link, Activity, Tx, Rx, COL, Mode, Dplx
P1/ISO/LED1	Link, Activity, Tx, Rx, COL, Mode, Dplx
P4/LED2	Link, Activity, Tx, Rx, COL, Mode, Dplx
LED3	Link, Activity, Tx, Rx, COL, Mode, Dplx
SI/LED4	Link, Activity, Tx, Rx, COL, Mode, Dplx

Note:

1. During either power-on reset or hardware reset, each multi-function configuration pin is an input that is sampled when the ICS1894-40 exits the reset state. After sampling is complete, these pins are output pins that can drive status LEDs.

2. A software reset does not affect the state of a multi-function configuration pin. During a software reset, all multi-function configuration pins are outputs.

3. The P0/LED0 and P1/ISO/LED1 pins must be pulled either up or down with an external resistor to establish the address of the ICS1894-40. The P2/INT, P3/RXD2 and P4/LED2 pins have internal pull-up/ pull-down resistors. LEDs may be placed in series with these resistors to provide a designated status indicator as described in the *Pins for Monitoring the Data Link* table. Use 1K Ω resistors.

Caution: Pins listed in the *Pins for Monitoring the Data Link* table must not float.

4. As outputs, the asserted state of a multi-function configuration pin is the inverse of the sense sampled during reset. This inversion provides a signal that can illuminate an LED during an asserted state. For example, if a multi-function configuration pin is pulled down to ground through an LED and a current-limiting resistor, then the sampled sense of the input is low. To illuminate this LED for the asserted state, the output is driven high.

5. Adding 10K Ω resistors across the LEDs ensures the PHY address is fully defined during slow VDD power-ramp conditions.

The following figure shows typical biasing and LED connections for the ICS1894-40.

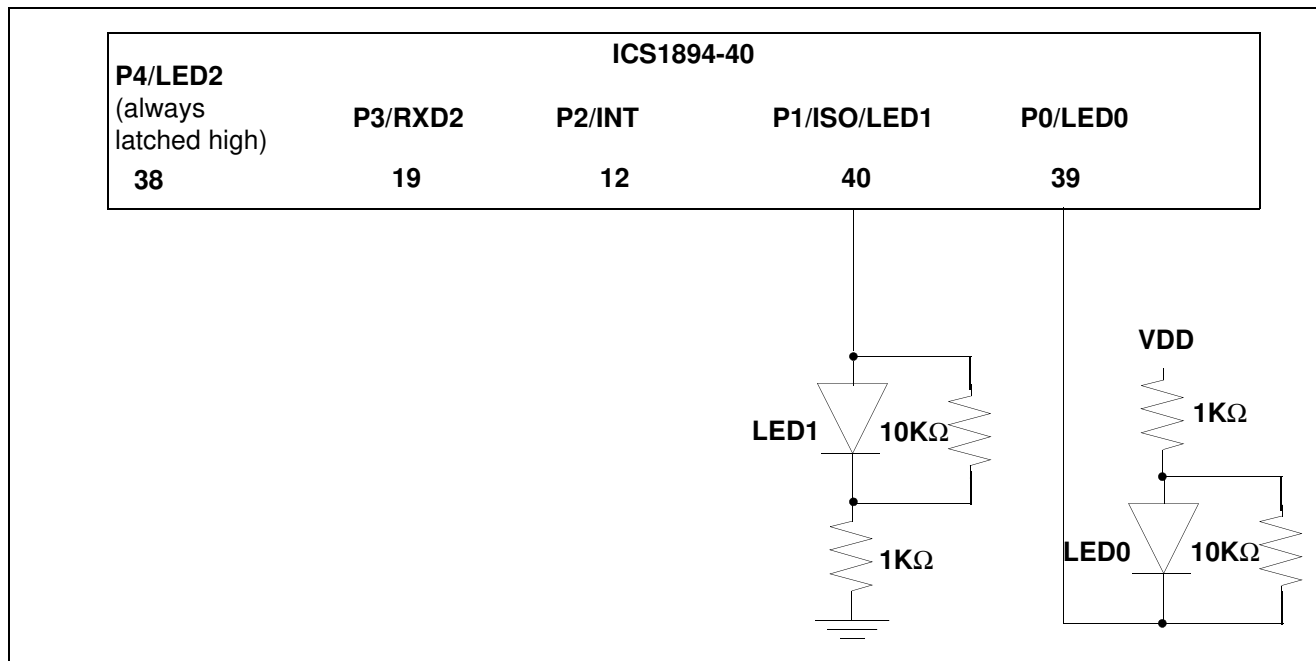

The above circuit decodes the PHY address = 17

Register Map

Register Address	Register Name	Basic / Extended
0	Control	Basic
1	Status	Basic
2,3	PHY Identifier	Extended
4	Auto-Negotiation Advertisement	Extended
5	Auto-Negotiation Link Partner Ability	Extended
6	Auto-Negotiation Expansion	Extended
7	Auto-Negotiation Next Page Transmit	Extended
8	Auto-Negotiation Next Page Link Partner Ability	Extended
9 through 15	Reserved by IEEE	Extended
16 through 31	Vendor-Specific (IDT) Registers	Extended

Register Description

Bit	Definition	When Bit = 0	When Bit = 1	Access ²	SF ²	Default ³	Hex
Register 0 - Control							
0.15	Reset	No effect	Reset mode	RW	SC	0	3
0.14	Loopback enable	Disable Loopback mode	Enable Loopback mode	RW	–	0	
0.13	Speed select ¹	10 Mbps operation	100 Mbps operation	RW	–	1	
0.12	Auto-Negotiation enable	Disable Auto-Negotiation	Enable Auto-Negotiation	RW	–	1	
0.11	Low-power mode	Normal power mode	Low-power mode	RW	–	0	1
0.10	Isolate	No effect	Isolate from MII	RW	–	0	
0.9	Auto-Negotiation restart	No effect	Restart Auto-Negotiation	RW	SC	0	
0.8	Duplex mode	Half-duplex operation	Full-duplex operation	RW	–	1	0
0.7	Collision test	No effect	Enable collision test	RW	–	0	
0.6	IEEE reserved	Always 0	N/A	RO	–	0†	
0.5	IEEE reserved	Always 0	N/A	RO	–	0†	
0.4	IEEE reserved	Always 0	N/A	RO	–	0†	
0.3	IEEE reserved	Always 0	N/A	RO	–	0†	0
0.2	IEEE reserved	Always 0	N/A	RO	–	0†	
0.1	IEEE reserved	Always 0	N/A	RO	–	0†	
0.0	IEEE reserved	Always 0	N/A	RO	–	0†	

Bit	Definition	When Bit = 0	When Bit = 1	Access ²	SF ²	Default ³	Hex
Register 1 - Control							
1.15	100Base-T4	Always 0. (Not supported.)	N/A	RO	–	0	7
1.14	100Base-TX full duplex	Mode not supported	Mode supported	CW	–	1	
1.13	100Base-TX half duplex	Mode not supported	Mode supported	CW	–	1	
1.12	10Base-T full duplex	Mode not supported	Mode supported	CW	–	1	
1.11	10Base-T half duplex	Mode not supported	Mode supported	CW	–	1	8
1.10	IEEE reserved	Always 0	N/A	CW	–	0†	
1.9	IEEE reserved	Always 0	N/A	CW	–	0†	
1.8	IEEE reserved	Always 0	N/A	CW	–	0†	
1.7	IEEE reserved	Always 0	N/A	CW	–	0†	0
1.6	MF Preamble suppression	PHY requires MF Preambles	PHY does not require MF Preambles	RO	–	0	
1.5	Auto-Negotiation complete	Auto-Negotiation is in process, if enabled	Auto-Negotiation is completed	RO	LH	0	
1.4	Remote fault	No remote fault detected	Remote fault detected	RO	LH	0	
1.3	Auto-Negotiation ability	N/A	Always 1: PHY has Auto-Negotiation ability	RO	–	1	9
1.2	Link status	Link is invalid/down	Link is valid/established	RO	LL	0	
1.1	Jabber detect	No jabber condition	Jabber condition detected	RO	LH	0	
1.0	Extended capability	N/A	Always 1: PHY has extended capabilities	RO	–	1	
Register 2 - PHY Identifier							
2.15	OUI bit 3 c	N/A	N/A	CW	–	0	0
2.14	OUI bit 4 d	N/A	N/A	CW	–	0	
2.13	OUI bit 5 e	N/A	N/A	CW	–	0	
2.12	OUI bit 6 f	N/A	N/A	CW	–	0	
2.11	OUI bit 7 g	N/A	N/A	CW	–	0	0
2.10	OUI bit 8 h	N/A	N/A	CW	–	0	
2.9	OUI bit 9 i	N/A	N/A	CW	–	0	
2.8	OUI bit 10 j	N/A	N/A	CW	–	0	
2.7	OUI bit 11 k	N/A	N/A	CW	–	0	1
2.6	OUI bit 12 l	N/A	N/A	CW	–	0	
2.5	OUI bit 13 m	N/A	N/A	CW	–	0	
2.4	OUI bit 14 n	N/A	N/A	CW	–	1	

Bit	Definition	When Bit = 0	When Bit = 1	Access ²	SF ²	Default ³	Hex
2.3	OUI bit 15 o	N/A	N/A	CW	–	0	5
2.2	OUI bit 16 p	N/A	N/A	CW	–	1	
2.1	OUI bit 17 q	N/A	N/A	CW	–	0	
2.0	OUI bit 18 r	N/A	N/A	CW	–	1	
Register 3 - PHY Identifier							
3.15	OUI bit 19 s	N/A	N/A	CW	–	1	F
3.14	OUI bit 20 t	N/A	N/A	CW	–	1	
3.13	OUI bit 21 u	N/A	N/A	CW	–	1	
3.12	OUI bit 22 v	N/A	N/A	CW	–	1	
3.11	OUI bit 23 w	N/A	N/A	CW	–	0	4
3.10	OUI bit 24 x	N/A	N/A	CW	–	1	
3.9	Manufacturer's Model Number bit 5	N/A	N/A	CW	–	0	
3.8	Manufacturer's Model Number bit 4	N/A	N/A	CW	–	0	5
3.7	Manufacturer's Model Number bit 3	N/A	N/A	CW	–	0	
3.6	Manufacturer's Model Number bit 2	N/A	N/A	CW	–	1	
3.5	Manufacturer's Model Number bit 1	N/A	N/A	CW	–	0	
3.4	Manufacturer's Model Number bit 0	N/A	N/A	CW	–	1	
3.3	Revision Number bit 3	N/A	N/A	CW	–	0	0
3.2	Revision Number bit 2	N/A	N/A	CW	–	0	
3.1	Revision Number bit 1	N/A	N/A	CW	–	0	
3.0	Revision Number bit 0	N/A	N/A	CW	–	0	
Register 4 - Auto-Negotiation Advertisement							
4.15	Next Page	Next page not supported	Next page supported	R/W	–	0	0
4.14	IEEE reserved	Always 0	N/A	CW	–	0†	
4.13	Remote fault	Locally, no faults detected	Local fault detected	R/W	–	0	
4.12	IEEE reserved	Always 0	N/A	CW	–	0†	
4.11	IEEE reserved	Always 0	N/A	CW	–	0†	1
4.10	IEEE reserved	Always 0	N/A	CW	–	0†	
4.9	100Base-T4	Always 0. (Not supported.)	N/A	CW	–	0	
4.8	100Base-TX, full duplex	Do not advertise ability	Advertise ability	R/W	–	1	

Bit	Definition	When Bit = 0	When Bit = 1	Access ²	SF ²	Default ³	Hex
4.7	100Base-TX, half duplex	Do not advertise ability	Advertise ability	R/W	–	1	E
4.6	10Base-T, full duplex	Do not advertise ability	Advertise ability	R/W	–	1	
4.5	10Base-T half duplex	Do not advertise ability	Advertise ability	R/W	–	1	
4.4	Selector Field bit S4	IEEE 802.3-specified default	N/A	CW	–	0	1
4.3	Selector Field bit S3	IEEE 802.3-specified default	N/A	CW	–	0	
4.2	Selector Field bit S2	IEEE 802.3-specified default	N/A	CW	–	0	
4.1	Selector Field bit S1	IEEE 802.3-specified default	N/A	CW	–	0	
4.0	Selector Field bit S0	N/A	IEEE 802.3-specified default	CW	–	1	
Register 5 - Auto-Negotiation Link Partner Ability							
5.15	Next Page	Next Page disabled	Next Page enabled	RO	–	0	0
5.14	Acknowledge	Always 0	N/A	RO	–	0	
5.13	Remote fault	No faults detected	Remote fault detected	RO	–	0	
5.12	IEEE reserved	Always 0	N/A	RO	–	0†	
5.11	IEEE reserved	Always 0	N/A	RO	–	0†	0
5.10	IEEE reserved	Always 0	N/A	RO	–	0†	
5.9	100Base-T4	Always 0. (Not supported.)	N/A	RO	–	0	
5.8	100Base-TX, full duplex	Link partner is not capable	Link partner is capable	RO	–	0	0
5.7	100Base-TX, half duplex	Link partner is not capable	Link partner is capable	RO	–	0	
5.6	10Base-T, full duplex	Link partner is not capable	Link partner is capable	RO	–	0	
5.5	10Base-T, half duplex	Link partner is not capable	Link partner is capable	RO	–	0	
5.4	Selector Field bit S4	IEEE 802.3 defined. Always 0.	N/A	RO	–	0	
5.3	Selector Field bit S3	IEEE 802.3 defined. Always 0.	N/A	CW	–	0	0
5.2	Selector Field bit S2	IEEE 802.3 defined. Always 0.	N/A	CW	–	0	
5.1	Selector Field bit S1	IEEE 802.3 defined. Always 0.	N/A	CW	–	0	
5.0	Selector Field bit S0	N/A	IEEE 802.3 defined. Always 1.	CW	–	0	

Bit	Definition	When Bit = 0	When Bit = 1	Access ²	SF ²	Default ³	Hex
Register 6 - Auto-Negotiation Expansion							
6.15	IEEE reserved	Always 0	N/A	CW	–	0†	0
6.14	IEEE reserved	Always 0	N/A	CW	–	0†	
6.13	IEEE reserved	Always 0	N/A	CW	–	0†	
6.12	IEEE reserved	Always 0	N/A	CW	–	0†	
6.11	IEEE reserved	Always 0	N/A	CW	–	0†	0
6.10	IEEE reserved	Always 0	N/A	CW	–	0†	
6.9	IEEE reserved	Always 0	N/A	CW	–	0†	
6.8	IEEE reserved	Always 0	N/A	CW	–	0†	
6.7	IEEE reserved	Always 0	N/A	CW	–	0†	0
6.6	IEEE reserved	Always 0	N/A	CW	–	0†	
6.5	IEEE reserved	Always 0	N/A	CW	–	0†	
6.4	Parallel detection fault	No Fault	Multiple technologies detected	RO	LH	0	
6.3	Link partner Next Page able	Link partner is not Next Page able	Link partner is Next Page able	RO	–	0	4
6.2	Next Page able	Local device is not Next Page able	Local device is Next Page able	RO	–	1	
6.1	Page received	Next Page not received	Next Page received	RO	LH	0	
6.0	Link partner Auto-Negotiation able	Link partner is not Auto-Negotiation able	Link partner is Auto-Negotiation able	RO	–	0	
Register 7 - Auto-Negotiation Next Page Transmit							
7.15	Next Page	Last Page	Additional Pages follow	RW	–	0	2
7.14	IEEE reserved	Always 0	N/A	RO	–	0†	
7.13	Message Page	Unformatted Page	Message Page	RW	–	1	
7.12	Acknowledge 2	Cannot comply with Message	Can comply with Message	RW	–	0	
7.11	Toggle	Previous Link Code Word was zero	Previous Link Code Word was one	RO	–	0	0
7.10	Message code field /Unformatted code field	Bit value depends on the particular message	Bit value depends on the particular message	RW	–	0	
7.9	Message code field /Unformatted code field	Bit value depends on the particular message	Bit value depends on the particular message	RW	–	0	
7.8	Message code field /Unformatted code field	Bit value depends on the particular message	Bit value depends on the particular message	RW	–	0	

Bit	Definition	When Bit = 0	When Bit = 1	Access ²	SF ²	Default ³	Hex
7.7	Message code field /Unformatted code field	Bit value depends on the particular message	Bit value depends on the particular message	RW	–	0	0
7.6	Message code field /Unformatted code field	Bit value depends on the particular message	Bit value depends on the particular message	RW	–	0	
7.5	Message code field /Unformatted code field	Bit value depends on the particular message	Bit value depends on the particular message	RW	–	0	
7.4	Message code field /Unformatted code field	Bit value depends on the particular message	Bit value depends on the particular message	RW	–	0	
7.3	Message code field /Unformatted code field	Bit value depends on the particular message	Bit value depends on the particular message	RW	–	0	1
7.2	Message code field /Unformatted code field	Bit value depends on the particular message	Bit value depends on the particular message	RW	–	0	
7.1	Message code field /Unformatted code field	Bit value depends on the particular message	Bit value depends on the particular message	RW	–	0	
7.0	Message code field /Unformatted code field	Bit value depends on the particular message	Bit value depends on the particular message	RW	–	1	
Register 8 - Auto-Negotiation Next Page Link Partner Ability							
8.15	Next Page	Last Page	Additional Pages follow	RO	–	0	0
8.14	IEEE reserved	Always 0	N/A	RO	–	0†	
8.13	Message Page	Unformatted Page	Message Page	RO	–	0	
8.12	Acknowledge 2	Cannot comply with Message	Can comply with Message	RO	–	0	
8.11	Toggle	Previous Link Code Word was zero	Previous Link Code Word was one	RO	–	0	0
8.10	Message code field /Unformatted code field	Bit value depends on the particular message	Bit value depends on the particular message	RO	–	0	
8.9	Message code field /Unformatted code field	Bit value depends on the particular message	Bit value depends on the particular message	RO	–	0	
8.8	Message code field /Unformatted code field	Bit value depends on the particular message	Bit value depends on the particular message	RO	–	0	
8.7	Message code field /Unformatted code field	Bit value depends on the particular message	Bit value depends on the particular message	RO	–	0	0
8.6	Message code field /Unformatted code field	Bit value depends on the particular message	Bit value depends on the particular message	RO	–	0	
8.5	Message code field /Unformatted code field	Bit value depends on the particular message	Bit value depends on the particular message	RO	–	0	
8.4	Message code field /Unformatted code field	Bit value depends on the particular message	Bit value depends on the particular message	RO	–	0	

Bit	Definition	When Bit = 0	When Bit = 1	Access ²	SF ²	Default ³	Hex
8.3	Message code field /Unformatted code field	Bit value depends on the particular message	Bit value depends on the particular message	RO	–	0	0
8.2	Message code field /Unformatted code field	Bit value depends on the particular message	Bit value depends on the particular message	RO	–	0	
8.1	Message code field /Unformatted code field	Bit value depends on the particular message	Bit value depends on the particular message	RO	–	0	
8.0	Message code field /Unformatted code field	Bit value depends on the particular message	Bit value depends on the particular message	RO	–	0	
Register 9 through 15 - Reserved by IEEE							
Register 16 - Extended Control Register							
16.15	Command Override Write enable	Disabled	Enabled	RW	SC	0	–
16.14	ICS reserved	Reserved	Reserved	RW/0	–	0	
16.13	ICS reserved	Reserved	Reserved	RW/0	–	0	
16.12	ICS reserved	Reserved	Reserved	RW/0	–	0	
16.11	ICS reserved	Reserved	Reserved	RW/0	–	0	
16.10	PHY Address Bit 4			RO	–	1	
16.9	PHY Address Bit 3			RO	–	L	
16.8	PHY Address Bit 2			RO	–	L	
16.7	PHY Address Bit 1			RO	–	L	
16.6	PHY Address Bit 0			RO	–	L	
16.5	Stream Cipher Test Mode	Normal operation	Test mode	RW	–	0	
16.4	ICS reserved	Read unspecified	Read unspecified	RW/0	–	–	
16.3	NRZ/NRZI encoding	NRZ encoding	NRZI encoding	RW	–	1	8
16.2	Transmit invalid codes	Disabled	Enabled	RW	–	0	
16.1	ICS reserved	Read unspecified	Read unspecified	RW/0	–	0	
16.0	Stream Cipher disable	Stream Cipher enabled	Stream Cipher disabled	RW	–	0	
Register 17 - Quick Poll Detailed Status Register							
17.15	Data rate	10 Mbps	100 Mbps	RO	–	–	–
17.14	Duplex	Half duplex	Full duplex	RO	–	–	
17.13	Auto-Negotiation Progress Monitor Bit 2	Reference Decode Table	Reference Decode Table	RO	LM X	0	
17.12	Auto-Negotiation Progress Monitor Bit 1	Reference Decode Table	Reference Decode Table	RO	LM X	0	

Bit	Definition	When Bit = 0	When Bit = 1	Access ²	SF ²	Default ³	Hex
17.11	Auto-Negotiation Progress Monitor Bit 0	Reference Decode Table	Reference Decode Table	RO	LM X	0	0
17.10	100Base-TX signal lost	Valid signal	Signal lost	RO	LH	0	
17.9	100BasePLL Lock Error	PLL locked	PLL failed to lock	RO	LH	0	
17.8	False Carrier detect	Normal Carrier or Idle	False Carrier	RO	LH	0	
17.7	Invalid symbol detected	Valid symbols observed	Invalid symbol received	RO	LH	0	0
17.6	Halt Symbol detected	No Halt Symbol received	Halt Symbol received	RO	LH	0	
17.5	Premature End detected	Normal data stream	Stream contained two IDLE symbols	RO	LH	0	
17.4	Auto-Negotiation complete	Auto-Negotiation in process	Auto-Negotiation complete	RO	–	0	
17.3	100Base-TX signal detect	Signal present	No signal present	RO	–	1	8
17.2	Jabber detect	No jabber detected	Jabber detected	RO	LH	0	
17.1	Remote fault	No remote fault detected	Remote fault detected	RO	LH	0	
17.0	Link Status	Link is not valid	Link is valid	RO	LL	0	
Register 18 - 10Base-T Operations Register							
18.15	Remote Jabber Detect	No Remote Jabber Condition detected	Remote Jabber Condition Detected	RO	LH	0	–
18.14	Polarity reversed	Normal polarity	Polarity reversed	RO	LH	0	
18.13	Data Bus Mode	Bit18.13 is latched pin RXTRI Bit18.12 is latched SI [1x]=RMII mode [01]=SI mode (Serial interface mode) [00]=MII mode		R0	–	–	
18.12				R0	–	L	
18.11	AMDIXEN	AMDIX disable	AMDIX enable	RW	–	L	–
18.10	RXTRI	RX output enable	RX tri-state for MII/RMII interface	RW	–	L	
18.9	REGEN	Vender reserved register access enable	Vender reserved register (byte25~byte31) access disable	RW	–	L	
18.8	TM_SWITCH	Switch TMUX2 to TMUX1, test control		RW	–	0	
18.7	IDT reserved	Read unspecified	Read unspecified	RW/0	–	–	–
18.6	IDT reserved	Read unspecified	Read unspecified	RW/0	–	–	
18.5	Jabber inhibit	Normal Jabber behavior	Jabber Check disabled	RW	–	0	
18.4	IDT reserved	Read unspecified	Read unspecified	RW/1	–	1	

Bit	Definition	When Bit = 0	When Bit = 1	Access ²	SF ²	Default ³	Hex
18.3	Auto polarity inhibit	Polarity automatically corrected	Polarity not automatically corrected	RW	–	0	0
18.2	SQE test inhibit	Normal SQE test behavior	SQE test disabled	RW	–	0	
18.1	Link Loss inhibit	Normal Link Loss behavior	Link Always = Link Pass	RW	–	0	
18.0	Squelch inhibit	Normal squelch behavior	No squelch	RW	–	0	
Register 19 - Extended Control Register							
19.15	Node Mode	Node mode	Repeater mode	RW	–	L	–
19.14	Hardware/Software Mode Speed Select	Use bit00.13 to select speed	Use real time input pin 22 only to select speed	RW	–	L	
19.13	Remote Fault	No faults detected	Remote fault detected	RO	–	0	
19.12	Register Bank select	[01]=Bank1, access register0x00~0x13 and registers 0x14~0x1F [00]=Bank0, access register0x00~0x13, new defined registers 0x14~0x25 [1x]=Bank0, same as [00]		RW	–	0	
19.11				RW	–	0	2
19.10	IDT reserved	Read unspecified	Read unspecified	RO	–	0	
19.9	AMDIX_EN	See Table on page 11	See Table on page 11	RW	–	1	
19.8	MDI_MODE	See Table on page 11	See Table on page 11	RW	–	0	
19.7	Twisted Pair Tri-State Enable, TPTRI	Twisted Pair Signals are not Tri-States or No effect	Twisted Pair Signals are Tri-States	RW	–	0	0
19.6	ICS reserved	Reserved	Reserved	RW	–	0	
19.5	ICS reserved	Reserved	Reserved	RW	–	0	
19.4	ICS reserved	Reserved	Reserved	RW	–	0	
19.3	ICS reserved	Reserved	Reserved	RW	–	0	1
19.2	ICS reserved	Reserved	Reserved	RW	–	0	
19.1	ICS reserved	Reserved	Reserved	RW	–	0	
19.0	Automatic 100Base-TX Power Down	Do not automatically power down	Power down automatically	RW	–	1	
Register 20 - Extended Control Register							
20.15	Str_enhance	Normal digital output strength	Enhance digital output strength in 1.8V condition	RW		0	3
20.14	Fast-off	Disable the function	Enable fast-off circuit	RW	–	0	
20.13	LED4 mode	00=Receive data 01=Collision 10=Full duplex 11=OFF (default LED4)		RW	–	1	
20.12						1	

Bit	Definition	When Bit = 0	When Bit = 1	Access ²	SF ²	Default ³	Hex
20.11	LED3 Mode	000 = Link Integrity 001 = activity/no activity 010 = Transmit Data 011 = Receive Data 100 = Collision 101 = 100/10 mode 110 = Full Duplex 111 = OFF (Default LED3)		RW	-	1	F
20.10						1	
20.9						1	
20.8	LED2 Mode	000 = Link Integrity 001 = activity/no activity 010 = Transmit Data 011 = Receive Data 100 = Collision 101 = 100/10 mode 110 = Full Duplex 111 = OFF (Default LED2)		RW		1	E
20.7						1	
20.6						1	
20.5	LED1 Mode	000 = Link Integrity 001 = activity/no activity 010 = Transmit Data 011 = Receive Data 100 = Collision 101 = 100/10 mode (Default LED1) 110 = Full Duplex 111 = OFF		RW		1	9
20.4						0	
20.3						1	
20.2	LED0 Mode	000 = Link Integrity 001 = activity/no activity (Default LED0) 010 = Transmit Data 011 = Receive Data 100 = Collision 101 = 100/10 mode 110 = Full Duplex 111 = LINK_STAT		RW		0	
20.1						0	
20.0						1	
Register 21 - Extended Control Register							
21.15:0	RXER_CNT	Receive error count for RMII mode		RW			0
Register 22 - Extended Control Register							
22.15	Interrupt output enable	Disable interrupt output	Enable interrupt output	RW		0	0
22.14	Interrupt flag read clear enable	Interrupt flag clear by read disable	Interrupt flag clear by read enable	RW		0	
22.13	Interrupt polarity	Output low when interrupt occur	Output high when interrupt occur	RW		0	
22.12	Interrupt flag auto clear enable	Interrupt flag unchanged when interrupt condition removed	Interrupt flag cleared when interrupt condition removed	RW		0	