



Chipsmall Limited consists of a professional team with an average of over 10 year of expertise in the distribution of electronic components. Based in Hongkong, we have already established firm and mutual-benefit business relationships with customers from,Europe,America and south Asia,supplying obsolete and hard-to-find components to meet their specific needs.

With the principle of “Quality Parts,Customers Priority,Honest Operation,and Considerate Service”,our business mainly focus on the distribution of electronic components. Line cards we deal with include Microchip,ALPS,ROHM,Xilinx,Pulse,ON,Everlight and Freescale. Main products comprise IC,Modules,Potentiometer,IC Socket,Relay,Connector.Our parts cover such applications as commercial,industrial, and automotives areas.

We are looking forward to setting up business relationship with you and hope to provide you with the best service and solution. Let us make a better world for our industry!



Contact us

Tel: +86-755-8981 8866 Fax: +86-755-8427 6832

Email & Skype: info@chipsmall.com Web: www.chipsmall.com

Address: A1208, Overseas Decoration Building, #122 Zhenhua RD., Futian, Shenzhen, China



PART NAME: KNOB SCALE: 1:1 DATE: 12/22/14 DR. BY JAM

DAVIES MOLDING COMPANY
CAROL STREAM, ILLINOIS 60188

P/N 1910EY
BASE PART 1910-12
SET SCREW I2486

THIS DRAWING IS THE PROPERTY OF DAVIES MOLDING COMPANY, IS SUBMITTED SOLELY AS A DESIGN OR ENGINEERING PROJECT. WE ACCEPT NO RESPONSIBILITY WHATSOEVER FOR THE PRACTICAL APPLICATION OF THE PIECES MADE TO THIS DESIGN.

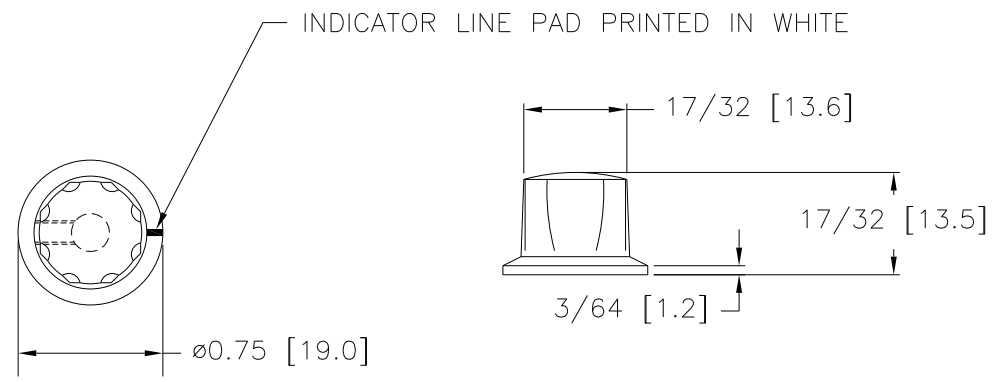

USE #40 DRILL($\phi 0.098$), M3X0.5 TAP, M3X0.5X5MM[0.197] SOCKET, CUP POINT, SET SCREW, I2486

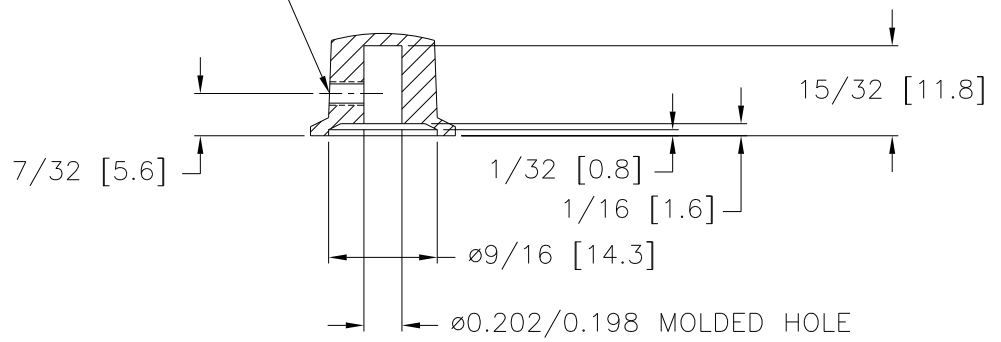

MATERIAL: G.P. PHENOLIC (B11)
COLOR: BLACK

| | | | | | |
|---|--|---------|---------------|-----|----------|
| TOLERANCES: UNLESS OTHERWISE SPECIFIED | DO NOT SCALE DRAWING | | | | |
| DECIMALS: X.XXX \pm .005 X.XX \pm .015 | MM: X.XX \pm 0.15MM X.X \pm 0.4MM | - | WAS SK1910-33 | JAM | 12/22/14 |
| FRACTIONS \pm 1/64 | ANG. \pm 1° | CHANGES | | | |