



Chipsmall Limited consists of a professional team with an average of over 10 year of expertise in the distribution of electronic components. Based in Hongkong, we have already established firm and mutual-benefit business relationships with customers from,Europe,America and south Asia,supplying obsolete and hard-to-find components to meet their specific needs.

With the principle of “Quality Parts,Customers Priority,Honest Operation,and Considerate Service”,our business mainly focus on the distribution of electronic components. Line cards we deal with include Microchip,ALPS,ROHM,Xilinx,Pulse,ON,Everlight and Freescale. Main products comprise IC,Modules,Potentiometer,IC Socket,Relay,Connector.Our parts cover such applications as commercial,industrial, and automotives areas.

We are looking forward to setting up business relationship with you and hope to provide you with the best service and solution. Let us make a better world for our industry!



## Contact us







Tel: +86-755-8981 8866 Fax: +86-755-8427 6832

Email & Skype: info@chipsmall.com Web: www.chipsmall.com

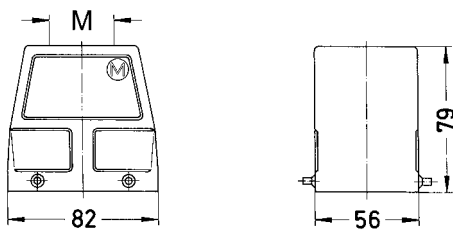
Address: A1208, Overseas Decoration Building, #122 Zhenhua RD., Futian, Shenzhen, China

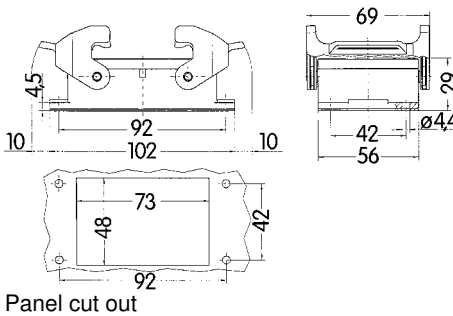

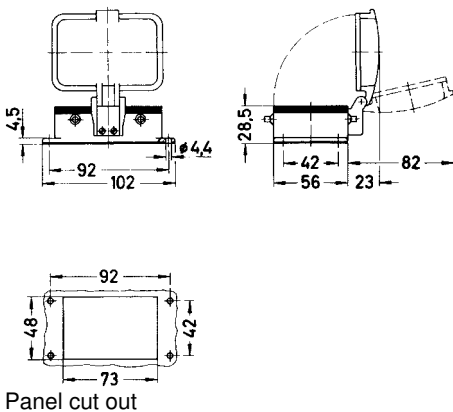

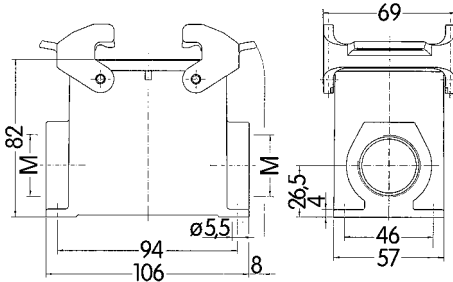
| Identification   | Cable entry             | Part number      |  | Drawing<br>Dimensions in mm  |
|--|-------------------------|------------------|--|--|
|  |                         | Low construction | High construction                                  |  |
| Han A®,<br>Hoods,<br>top entry<br><br>  | 1xM25<br>1xM32          |                  | 19 20 032 0426<br>19 20 032 0427                   |                         |
| Han A®,<br>Bulkhead mounted housings,<br>Han-Easy Lock®<br><br>                 |                         | 09 20 032 0301   |  |  <p>Panel cut out</p>   |
| Han A®,<br>Bulkhead mounted housings,<br>with thermo-plastic cover<br><br>    |                         | 09 20 032 0302   |  |  <p>Panel cut out</p> |
| Han A®,<br>Surface mounted housings,<br>side entry,<br>Han-Easy Lock®<br><br> | 1xM25<br>1xM32<br>2xM32 |                  | 19 20 032 0231<br>19 20 032 0232<br>19 20 032 0272 |                       |

Hoods  
Housings