



Chipsmall Limited consists of a professional team with an average of over 10 year of expertise in the distribution of electronic components. Based in Hongkong, we have already established firm and mutual-benefit business relationships with customers from,Europe,America and south Asia,supplying obsolete and hard-to-find components to meet their specific needs.

With the principle of “Quality Parts,Customers Priority,Honest Operation,and Considerate Service”,our business mainly focus on the distribution of electronic components. Line cards we deal with include Microchip,ALPS,ROHM,Xilinx,Pulse,ON,Everlight and Freescale. Main products comprise IC,Modules,Potentiometer,IC Socket,Relay,Connector.Our parts cover such applications as commercial,industrial, and automotives areas.

We are looking forward to setting up business relationship with you and hope to provide you with the best service and solution. Let us make a better world for our industry!



Contact us

Tel: +86-755-8981 8866 Fax: +86-755-8427 6832

Email & Skype: info@chipsmall.com Web: www.chipsmall.com

Address: A1208, Overseas Decoration Building, #122 Zhenhua RD., Futian, Shenzhen, China



THIS DRAWING IS UNPUBLISHED. RELEASED FOR PUBLICATION
 © COPYRIGHT BY TYCO ELECTRONICS CORPORATION. ALL RIGHTS RESERVED.

LOC	DIST	REVISIONS					
GE	00	P	LTR	DESCRIPTION	DATE	DWN	APVD
		B		REVISED PER ECO-09-007254	26MAR2009	DD	MT

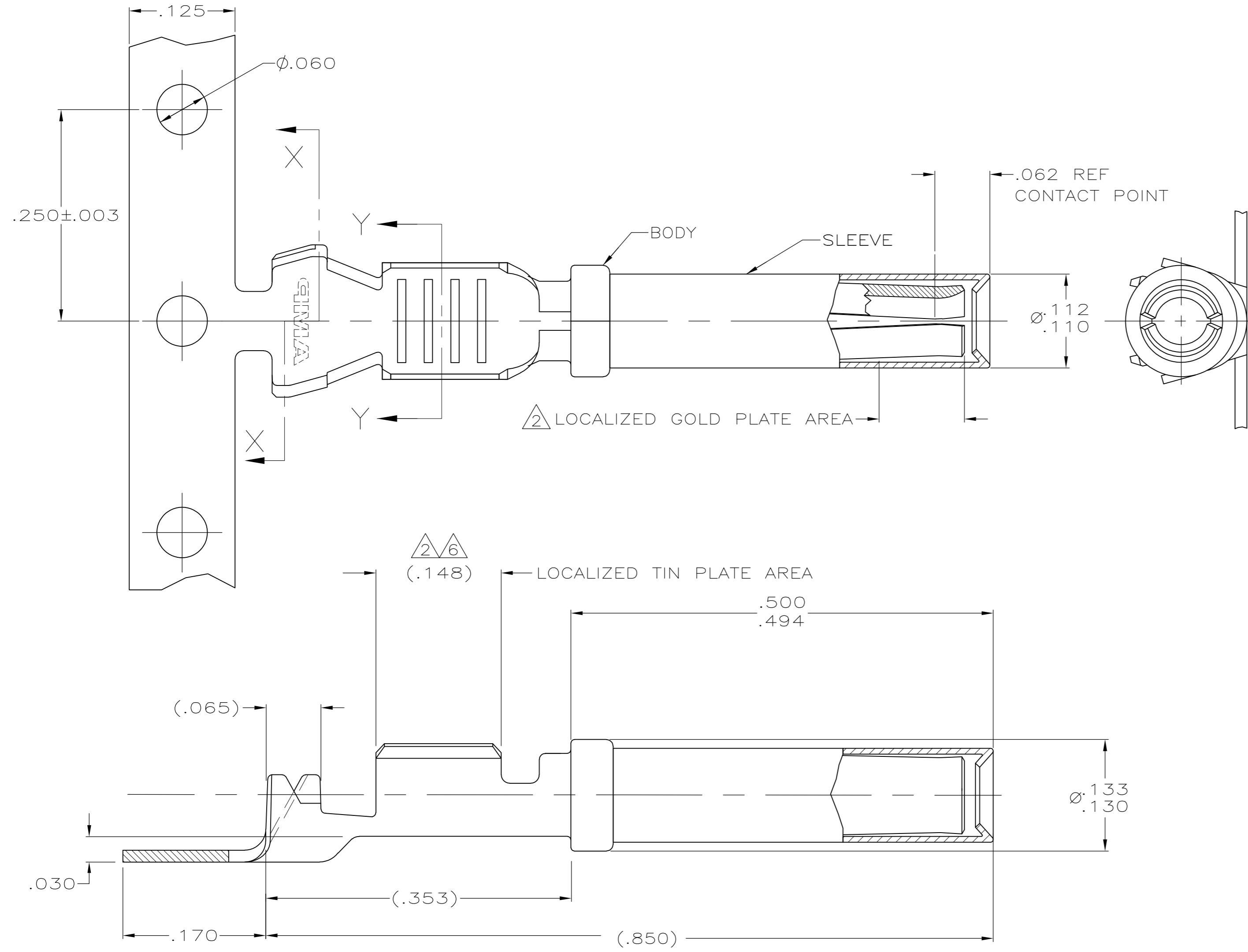

- 1 MATERIAL:
BODY: .014 THK. COPPER ALLOY.
SLEEVE: .007 THK. STAINLESS STEEL.
- 2 FINISH:
BODY: .000030 MIN SELECT GOLD IN LOCALIZED GOLD PLATE AREA, AND .000100-.000200 TIN IN LOCALIZED TIN PLATE AREA.
ALL OVER: .000040-.000080 THK. NICKEL.
SLEEVE: PASSIVATE PER 112-230-2, METHOD 1.
- 3. CONTACT TO BE LUBED WITH LUBRICANT PER TYCO ELECTRONICS P/N 22014-4.
- 4. WIRE RANGE: 20-18 AWG WITH INSULATION DIAMETERS OF .050 - .107 INCHES.
- 5. SLEEVE MUST WITHSTAND PULL OFF FORCE IN DIRECTION PARALLEL TO CENTER OF TERMINAL OF 10 LBS MINIMUM.
- 6 MATERIAL:
BODY: .000100 - .000200 TIN IN LOCALIZED TIN PLATE AREA.
ALL OVER: .000040 - .000080 THK NICKEL.
SLEEVE: PASSIVATE PER 112-230-2, METHOD 1.

2/6
(.148)

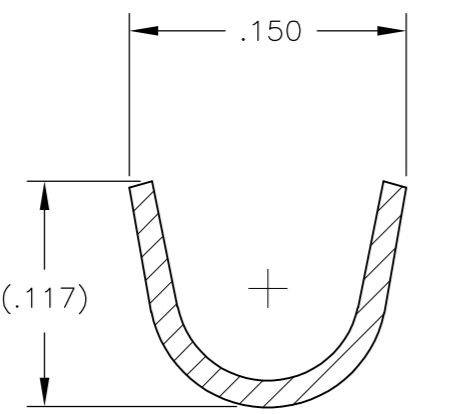

SECTION X-X

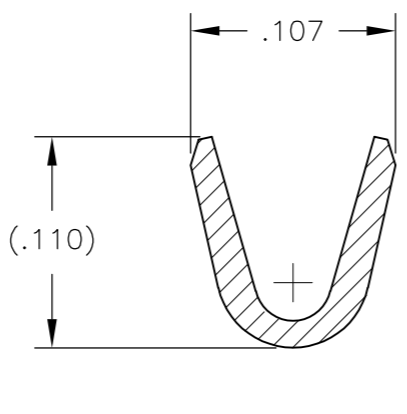

SECTION Y-Y

THIS DRAWING IS A CONTROLLED DOCUMENT.		DWN DL DRUMMOND 27AUG2007	Tyco Electronics Corporation Harrisburg, PA 17105-3608	
DIMENSIONS: INCHES		CHK MP TRULL 27AUG2007		
TOLERANCES UNLESS OTHERWISE SPECIFIED:		APVD MP TRULL 27AUG2007	NAME	
0 PLC ± -	1 PLC ± -	PRODUCT SPEC	ASSEMBLY, SOCKET	
2 PLC ± .02	3 PLC ± .005	APPLICATION SPEC	SIZE A2	CAGE CODE 00779
4 PLC ± -	ANGLES ± -	WEIGHT -	DRAWING NO C=1924464	RESTRICTED TO -
MATERIAL 1	FINISH SEE TABLE	CUSTOMER DRAWING	SCALE 10:1	SHEET 1 OF 1
			REV B	

1924464