



Chipsmall Limited consists of a professional team with an average of over 10 year of expertise in the distribution of electronic components. Based in Hongkong, we have already established firm and mutual-benefit business relationships with customers from,Europe,America and south Asia,supplying obsolete and hard-to-find components to meet their specific needs.

With the principle of “Quality Parts,Customers Priority,Honest Operation,and Considerate Service”,our business mainly focus on the distribution of electronic components. Line cards we deal with include Microchip,ALPS,ROHM,Xilinx,Pulse,ON,Everlight and Freescale. Main products comprise IC,Modules,Potentiometer,IC Socket,Relay,Connector.Our parts cover such applications as commercial,industrial, and automotives areas.

We are looking forward to setting up business relationship with you and hope to provide you with the best service and solution. Let us make a better world for our industry!



## Contact us

Tel: +86-755-8981 8866 Fax: +86-755-8427 6832

Email & Skype: info@chipsmall.com Web: www.chipsmall.com

Address: A1208, Overseas Decoration Building, #122 Zhenhua RD., Futian, Shenzhen, China



THIS DRAWING IS UNPUBLISHED. RELEASED FOR PUBLICATION 20  
 © COPYRIGHT 20 BY TYCO ELECTRONICS CORPORATION. ALL RIGHTS RESERVED.

LOC	DIST	REVISIONS			
P	LTR	DESCRIPTION	DATE	DWN	APVD
ES	00	A2	OBSOLETE ECO-18-012430	04SEP18	K.G W.H

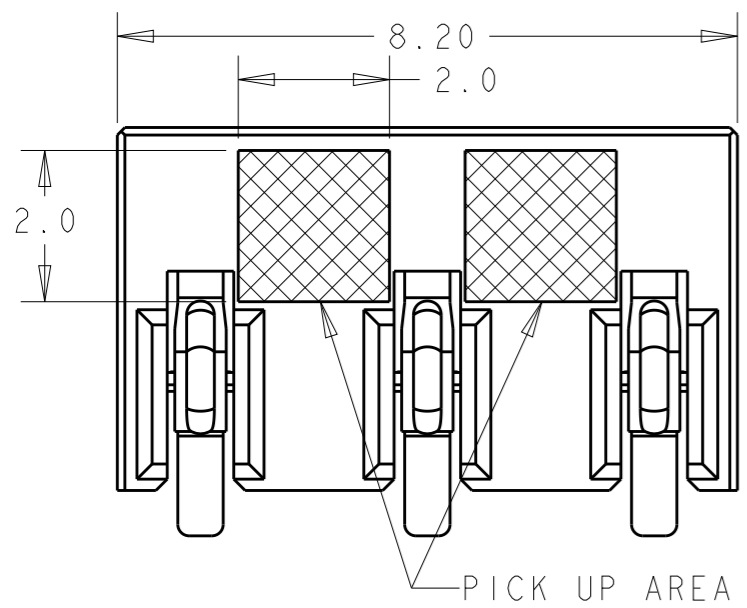

- 1 MATERIAL:  
CONTACT: COPPER ALLOY.  
HOUSING: THERMOPLASTIC BLACK LCP OR EQUIVALENT, UL 94V-0.
- 2 FINISH: 15 MICROINCH (0.38 MICRON) GOLD PLATING ON CONTACT AREA,  
GOLD FLASH PLATING ON SOLDER AREA,  
OVER 50 MICROINCH (1.27 MICRON) NICKEL PLATING OVERALL.
- 3 PRODUCT TO BE PACKAGED IN ANTI-STATIC TAPE AND REEL.
- 4 NORMAL FORCE IS 80g MIN. WHEN A CONTACT PRESSURE TO THE POSITION.

1932076-1 AS SHOWN

OBSOLETE

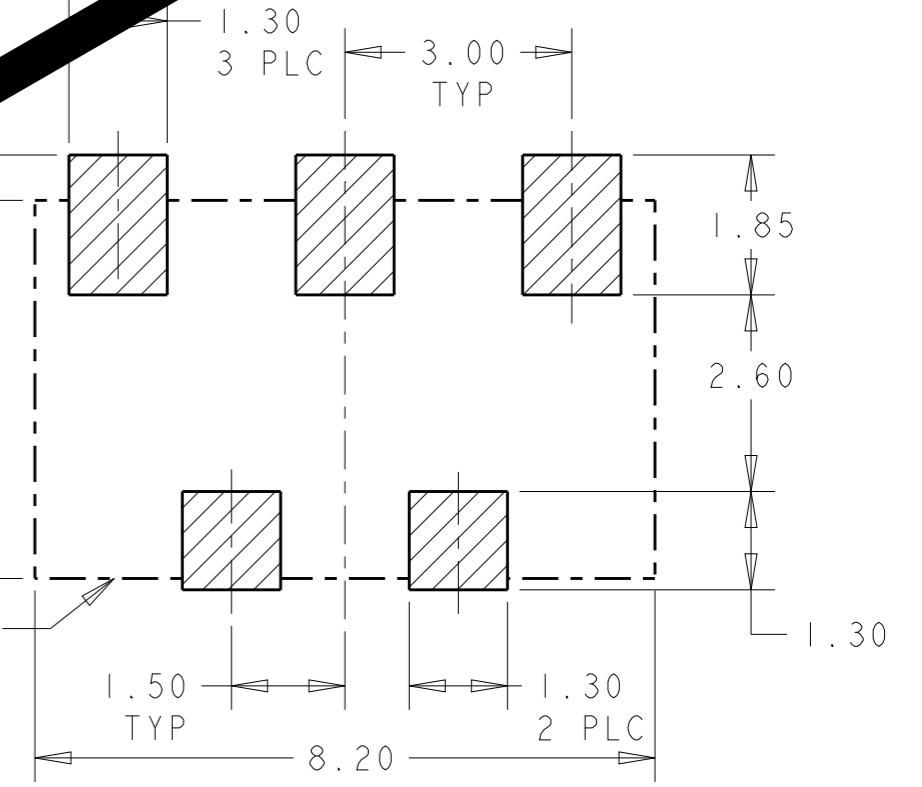
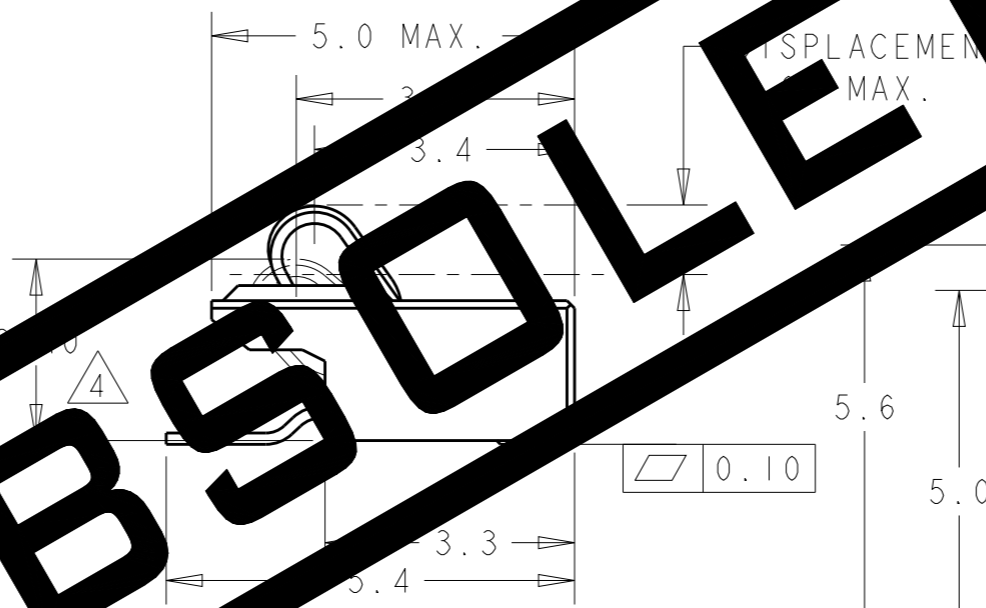
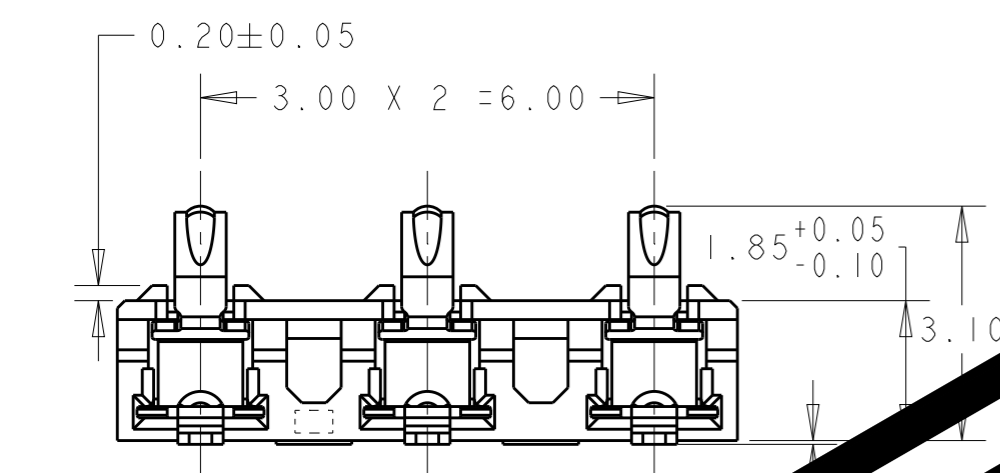

RECOMMENED PCB LAYOUT (TOLERANCE ±0.05)

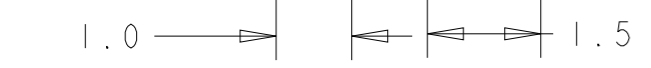
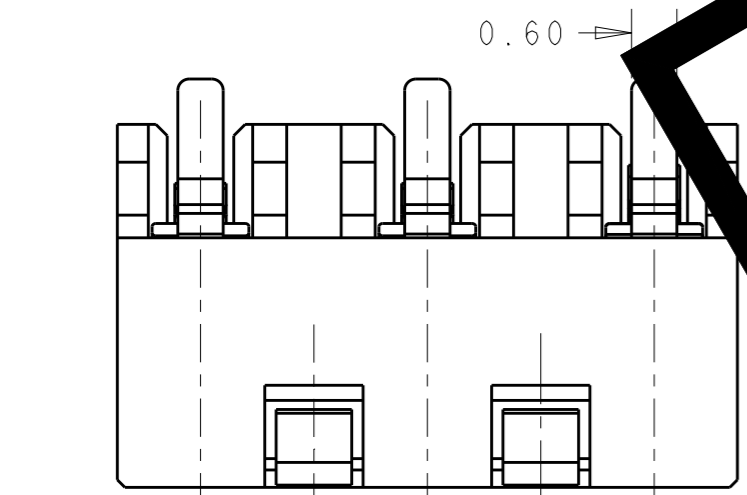

<small>THIS DRAWING IS A CONTROLLED DOCUMENT FOR TYCO ELECTRONICS CORPORATION. IT IS SUBJECT TO CHANGE AND THE CONTROLLING ENGINEERING ORGANIZATION SHOULD BE CONTACTED FOR THE LATEST REVISION.</small>		DWN 06-NOV-07 Lesson, Li CHK 06-NOV-07 Wenke, He APVD 06-NOV-07 Steven Yao		Tyco Electronics Shanghai, P.R.China, 200233	
DIMENSIONS: mm		TOLERANCES UNLESS OTHERWISE SPECIFIED: 0 PLC ±- 1 PLC ±0.2 2 PLC ±0.10 3 PLC ±0.05 4 PLC ±- ANGLES ±-		NAME 3.0mm PITCH 3 PIN SMT TYPE BATTERY CONNECTOR HEIGHT=3.15mm	
MATERIAL SEE NOTES 1		FINISH SEE NOTES 2 3		PRODUCT SPEC 108-60068 APPLICATION SPEC - WEIGHT -	
CUSTOMER DRAWING		SCALE 15:1		SHEET 1 OF 1 REV A2	