



Chipsmall Limited consists of a professional team with an average of over 10 year of expertise in the distribution of electronic components. Based in Hongkong, we have already established firm and mutual-benefit business relationships with customers from,Europe,America and south Asia,supplying obsolete and hard-to-find components to meet their specific needs.

With the principle of “Quality Parts,Customers Priority,Honest Operation,and Considerate Service”,our business mainly focus on the distribution of electronic components. Line cards we deal with include Microchip,ALPS,ROHM,Xilinx,Pulse,ON,Everlight and Freescale. Main products comprise IC,Modules,Potentiometer,IC Socket,Relay,Connector.Our parts cover such applications as commercial,industrial, and automotives areas.

We are looking forward to setting up business relationship with you and hope to provide you with the best service and solution. Let us make a better world for our industry!



## Contact us

Tel: +86-755-8981 8866 Fax: +86-755-8427 6832

Email & Skype: info@chipsmall.com Web: www.chipsmall.com

Address: A1208, Overseas Decoration Building, #122 Zhenhua RD., Futian, Shenzhen, China



4

3

2

1

THIS DRAWING IS UNPUBLISHED. RELEASED FOR PUBLICATION  
 © COPYRIGHT 2003 BY TYCO ELECTRONICS CORPORATION. ALL INTERNATIONAL RIGHTS RESERVED.

LOC	DIST	REVISIONS					
J	-	P	LTR	DESCRIPTION	DATE	DWN	APVD
		A		RELEASE	07JUN11	TQ	SY

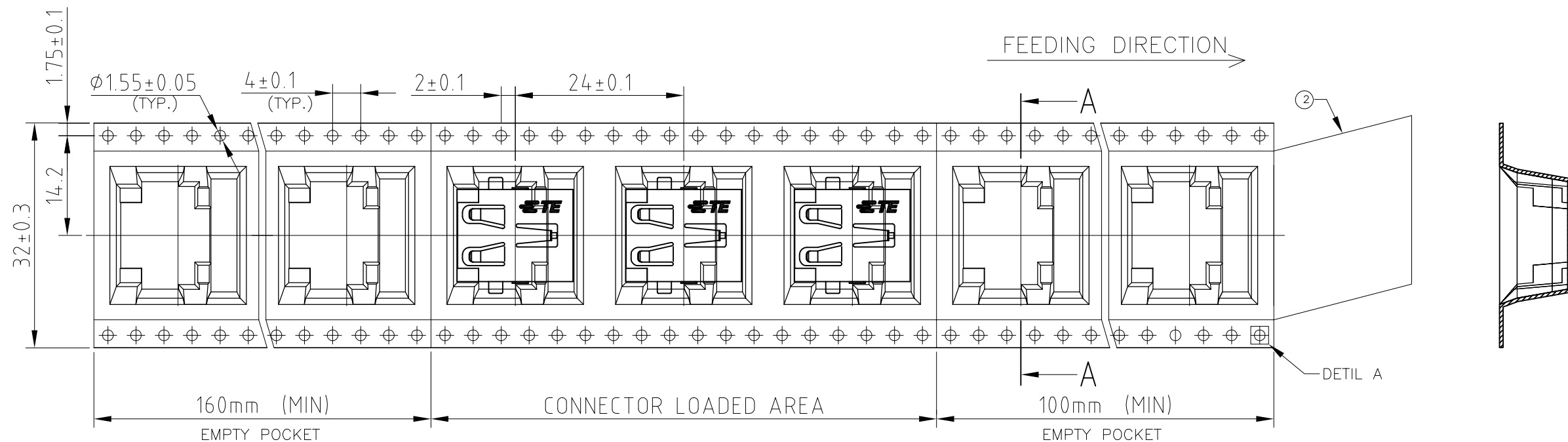

- NOTES :
- 10 POCKETS HOLE PITCH CUMULATIVE TOLERANCE  $\pm 0.2\text{mm}$  .
  - NUMBER OF CONNECTORS : 230 PCS/REEL .
  - COVER TAPE PEELING STRENGTH : 0.1 ~ 1.3N . AT 300mm/min .

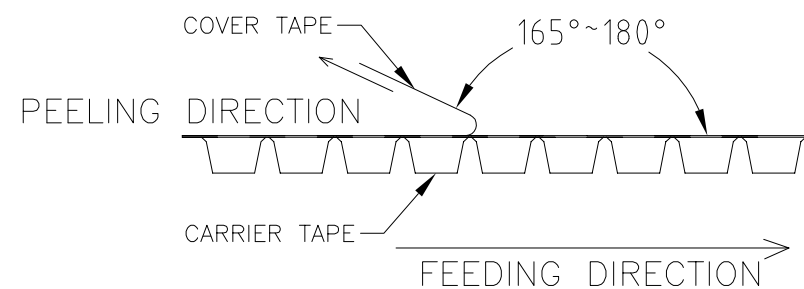
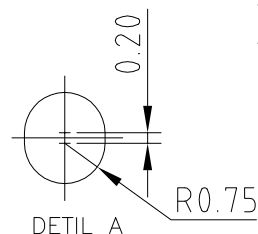
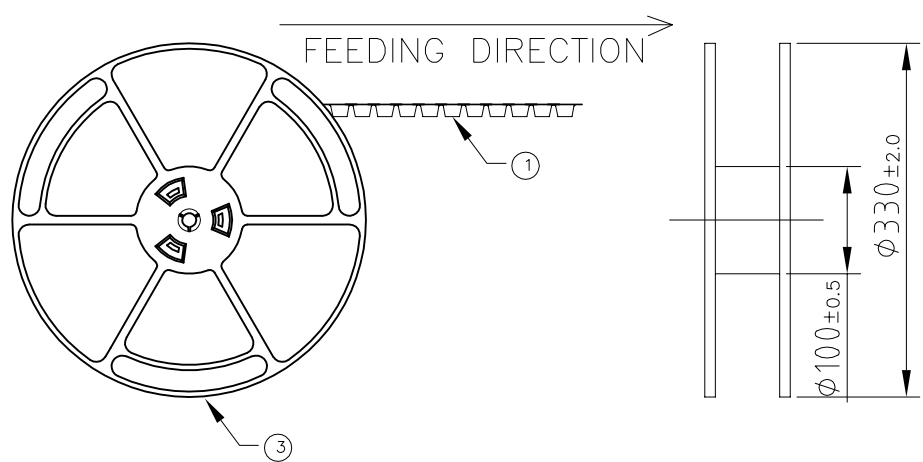

BLACK	1932733-1
COLOR	PARTS No.

THIS DRAWING IS A CONTROLLED DOCUMENT.		DWN Tommy Qian 07JUN11				
		CHK Martin Li 07JUN11				
DIMENSIONS: mm 		APVD Steven Yao 07JUN11	NAME			
TOLERANCES UNLESS OTHERWISE SPECIFIED: 0 PLC $\pm 0.3$ 1 PLC $\pm$ 2 PLC $\pm 0.3$ 3 PLC $\pm$ 4 PLC $\pm$ ANGLES $\pm 3^\circ$		PRODUCT SPEC 108-5983	USB CONNECTOR RECEPTACLE DIP AND OFFSET TYPE			
MATERIAL 1		FINISH 2	SIZE A3	CAGE CODE 00779	DRAWING NO C=1932733	RESTRICTED TO
CUSTOMER DRAWING			SCALE 6:1	SHEET 1 of 2	REV A	

THIS DRAWING IS UNPUBLISHED. RELEASED FOR PUBLICATION  
 © COPYRIGHT 2003 BY TYCO ELECTRONICS CORPORATION. ALL INTERNATIONAL RIGHTS RESERVED.

LOC		DIST		REVISIONS			
P	LTR	DESCRIPTION		DATE	DWN	APVD	
J		-		SEE SHEET 1	-	-	

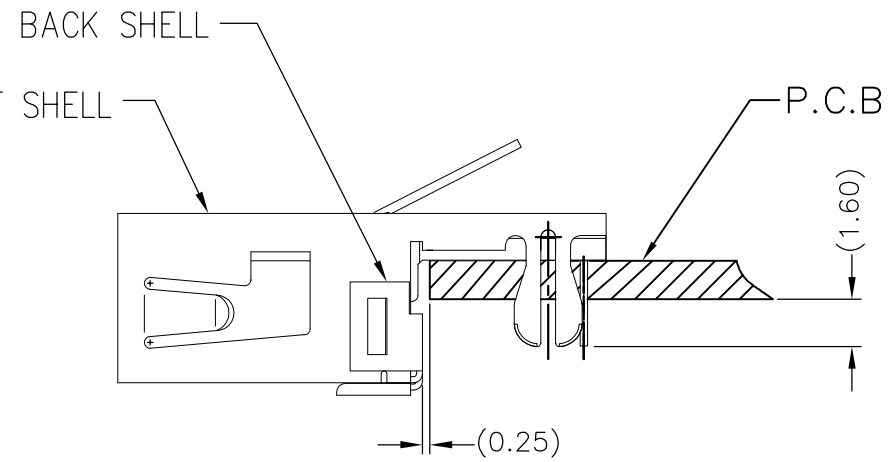
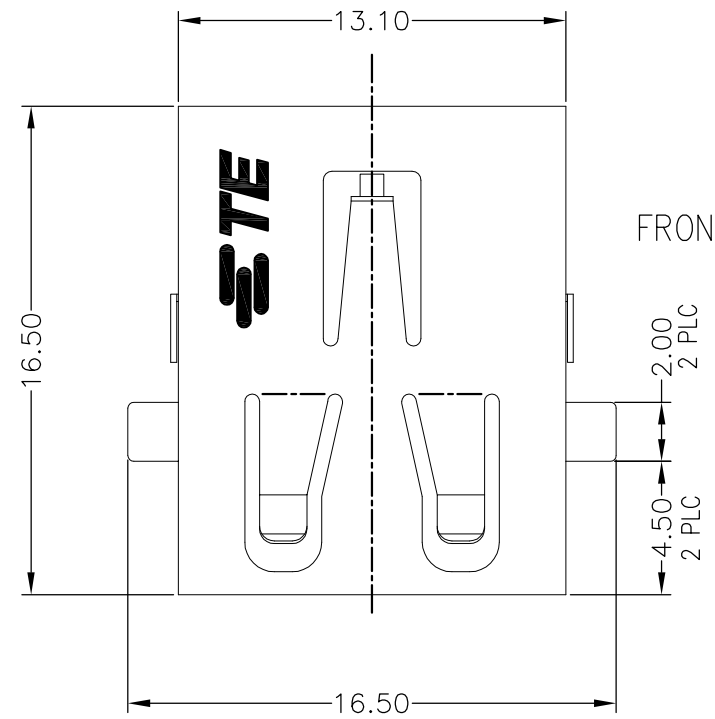

REFERENCE P.C.B LAYOUT  
(SIDE VIEW, 1.3mm THK)

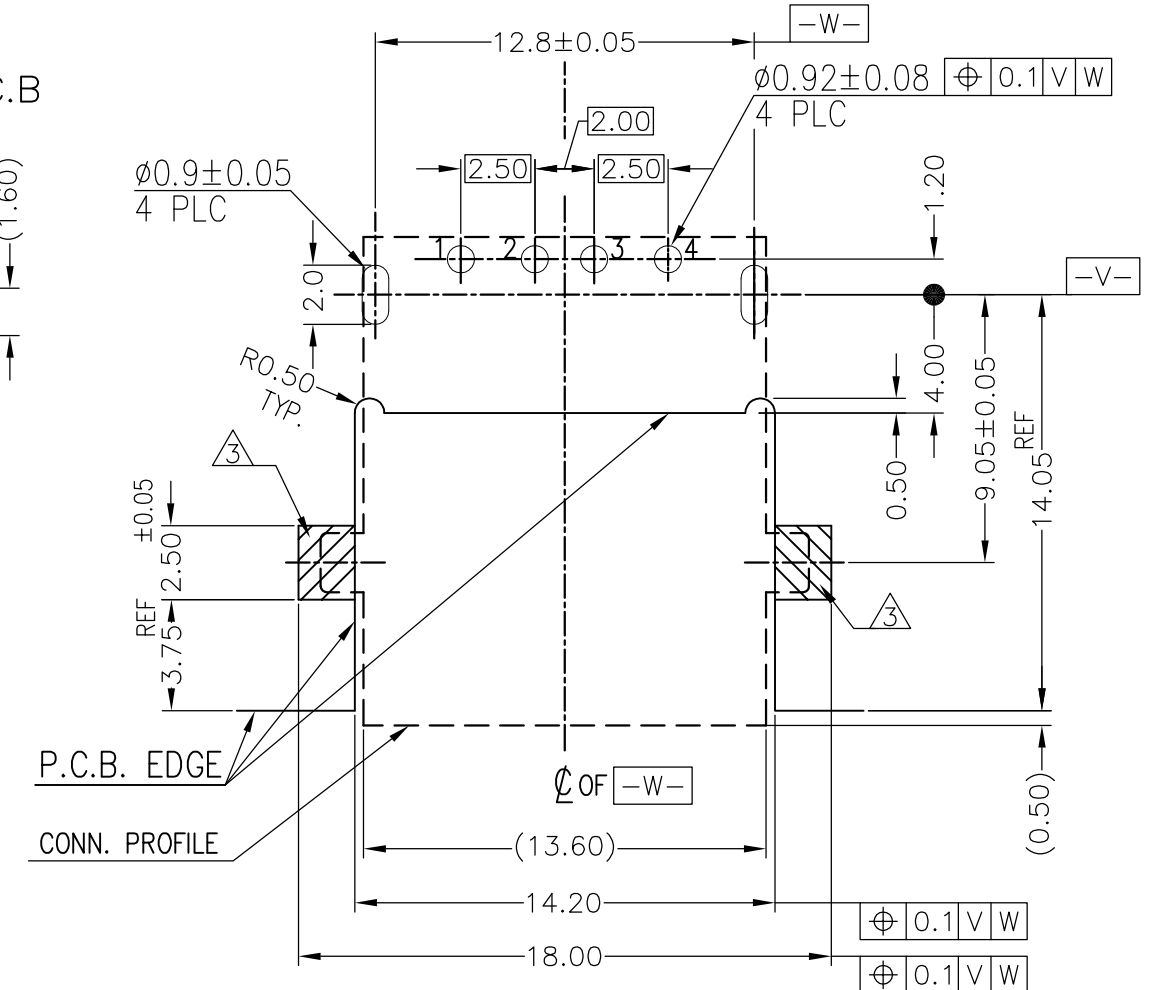
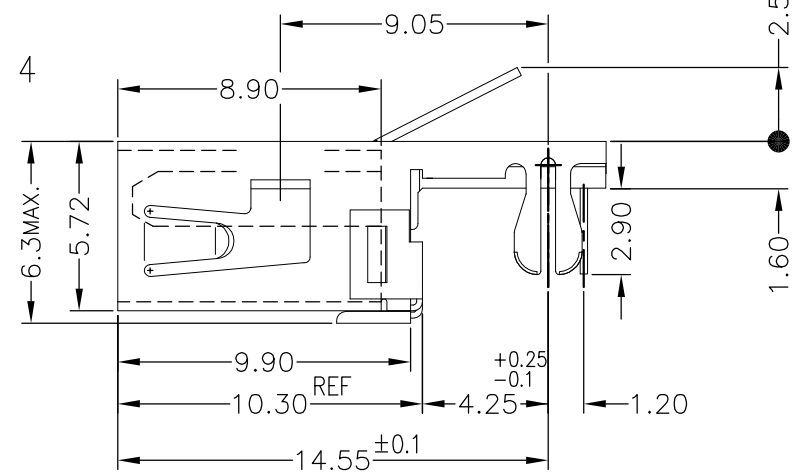
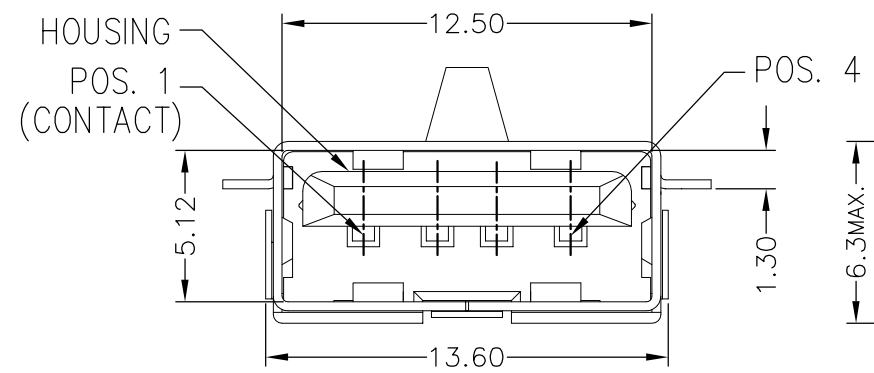

REFERENCE P.C.B LAYOUT  
(TOP VIEW, 1.1~1.3mm PWB THK)

- 1 MATERIAL  
HOUSING: HIGH TEMPERATURE THERMOPLASTIC, BLACK, HALOGEN FREE, UL 94V-0  
CONTACT: COPPER ALLOY  
FRONT SHELL: COPPER ALLOY  
BACK SHELL: COPPER ALLOY
- 2 FINISH  
CONTACT: NICKEL UNDER PLATE ALL OVER.  
CONTACT AREA: GOLD PLATING  
TINE AREA: Tin PLATING  
FRONT SHELL: Tin PLATING, Ni UNDER PLATING  
BACK SHELL: Ni PLATING
- 3 NO COMPONENT AREA.

THIS DRAWING IS A CONTROLLED DOCUMENT.

DIMENSIONS:	TOLERANCES UNLESS OTHERWISE SPECIFIED:
mm	
	0 PLC ±
	1 PLC ±0.3
	2 PLC ±0.3
	3 PLC ±
	4 PLC ±
	ANGLES ±3°
MATERIAL	FINISH
1	2

DWN	Tommy Qian	07JUN11
CHK	Martin Li	07JUN11
APVD	Steven Yao	07JUN11
PRODUCT SPEC	108-5983	
APPLICATION SPEC		
WEIGHT		
CUSTOMER DRAWING		

**TE** TE Connectivity

NAME: USB CONNECTOR RECEPTACLE DIP AND OFFSET TYPE

SIZE	CAGE CODE	DRAWING NO	RESTRICTED TO
A3	00779	C-1932733	

SCALE: 4:1 SHEET: 2 OF 2 REV: A