



Chipsmall Limited consists of a professional team with an average of over 10 year of expertise in the distribution of electronic components. Based in Hongkong, we have already established firm and mutual-benefit business relationships with customers from,Europe,America and south Asia,supplying obsolete and hard-to-find components to meet their specific needs.

With the principle of “Quality Parts,Customers Priority,Honest Operation,and Considerate Service”,our business mainly focus on the distribution of electronic components. Line cards we deal with include Microchip,ALPS,ROHM,Xilinx,Pulse,ON,Everlight and Freescale. Main products comprise IC,Modules,Potentiometer,IC Socket,Relay,Connector.Our parts cover such applications as commercial,industrial, and automotives areas.

We are looking forward to setting up business relationship with you and hope to provide you with the best service and solution. Let us make a better world for our industry!



Contact us

Tel: +86-755-8981 8866 Fax: +86-755-8427 6832

Email & Skype: info@chipsmall.com Web: www.chipsmall.com

Address: A1208, Overseas Decoration Building, #122 Zhenhua RD., Futian, Shenzhen, China



LOC	DIST	REVISIONS					
		P	LTN	DESCRIPTION	DATE	DWN	APVD
HM	00	B		REV; ECO-13-004517	13MAR2013	GG	RA
		C		REV; ECO-13-009275	04JUN2013	GG	RA

- △ MATERIAL:
 HOUSING - UL 94V-0 RATED ABS.
 SEE TABLE FOR COLOR.
- CONNECTOR: STANDARD USB A AND B TYPE.
 - COMPLIES WITH ROHS DIRECTIVE 2002/95/EC TO BE LEAD FREE.

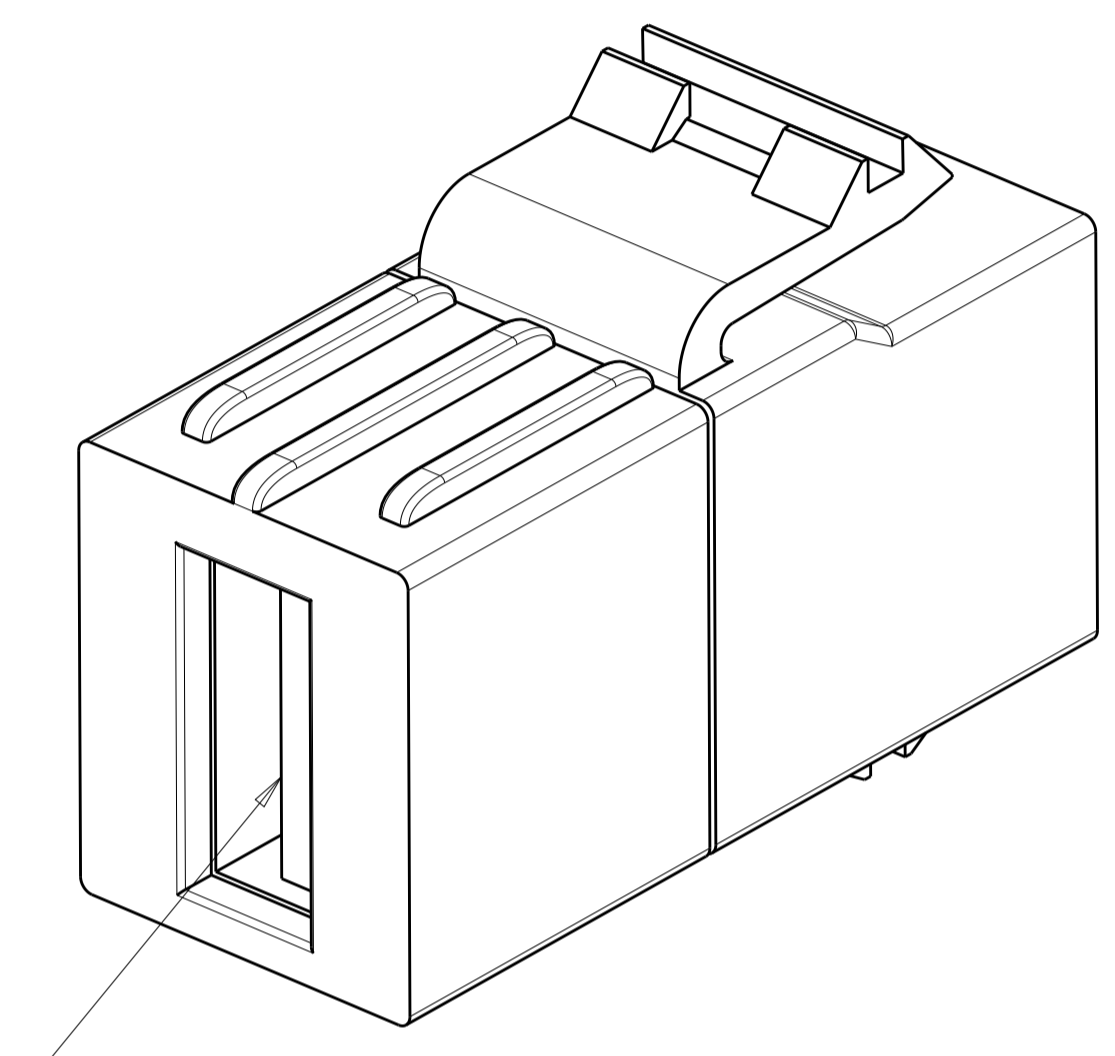
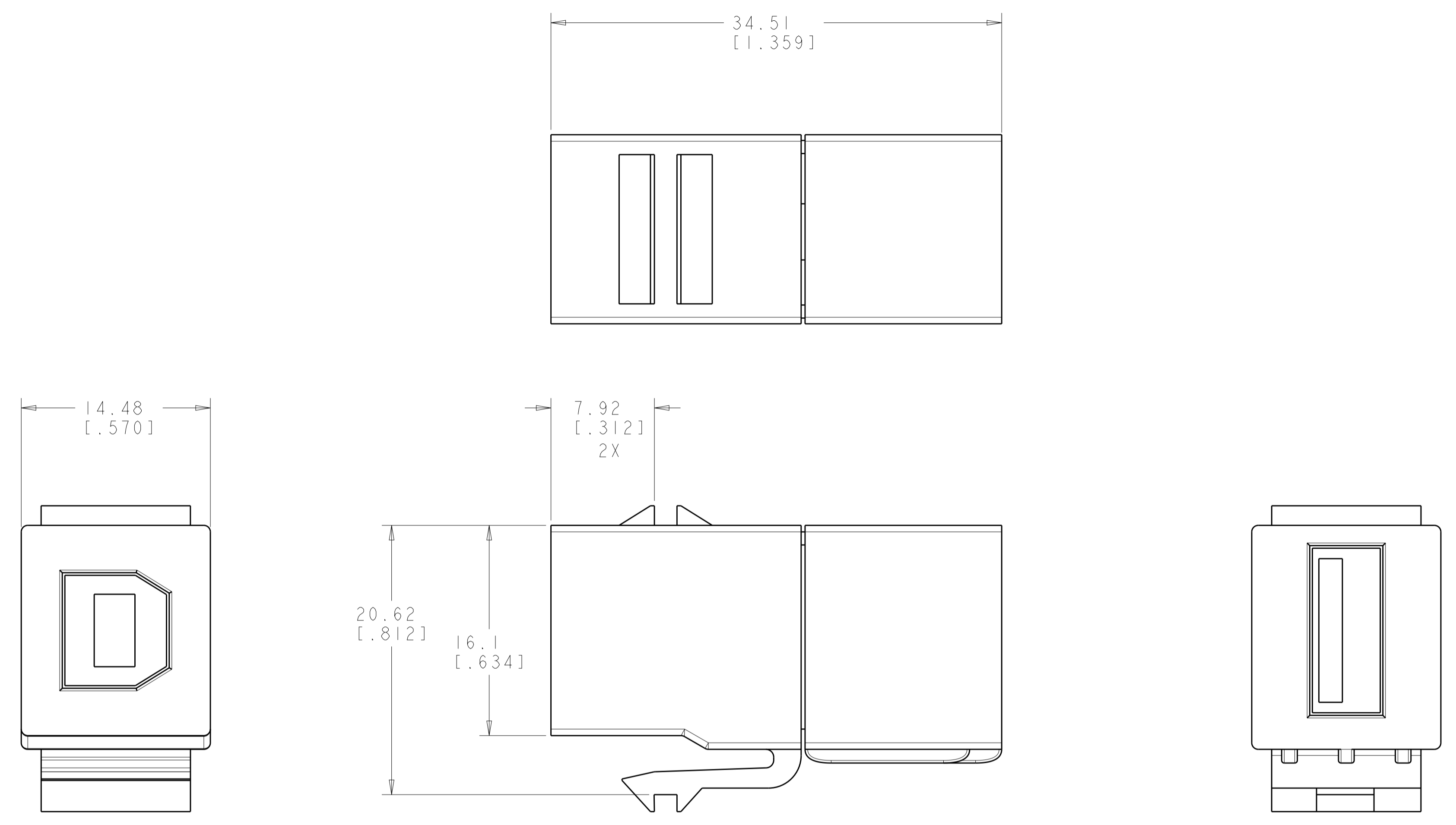

USB TYPE-A RECEPTACLE

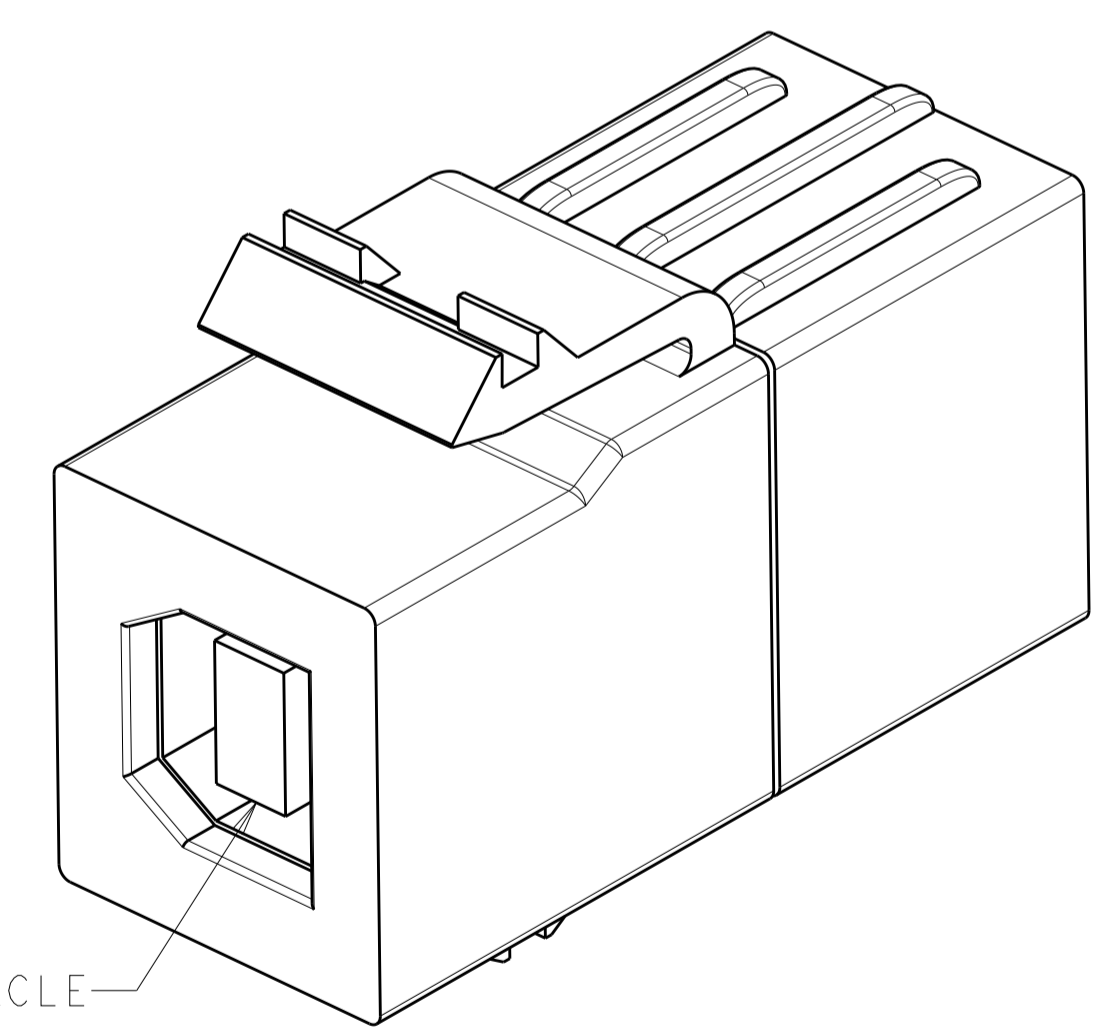
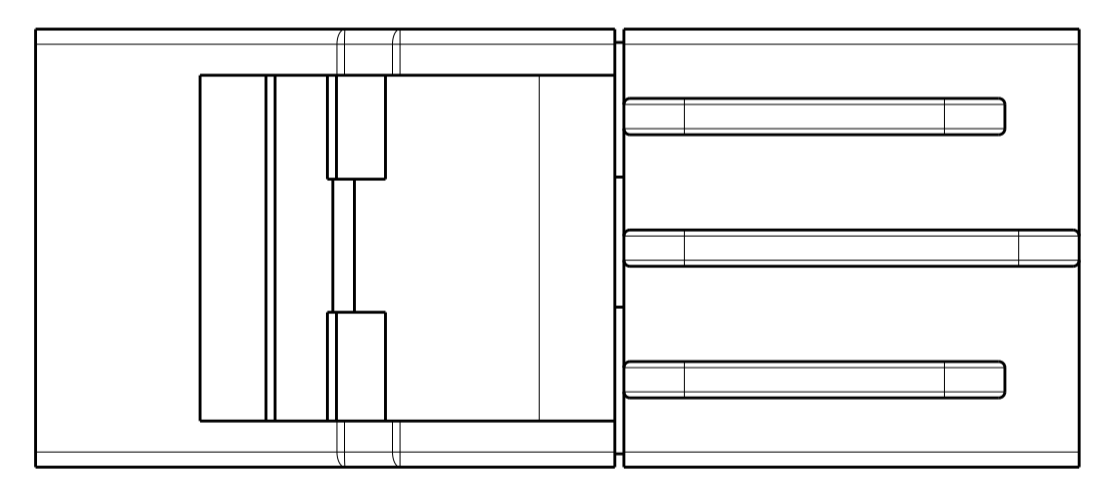

USB TYPE-B RECEPTACLE

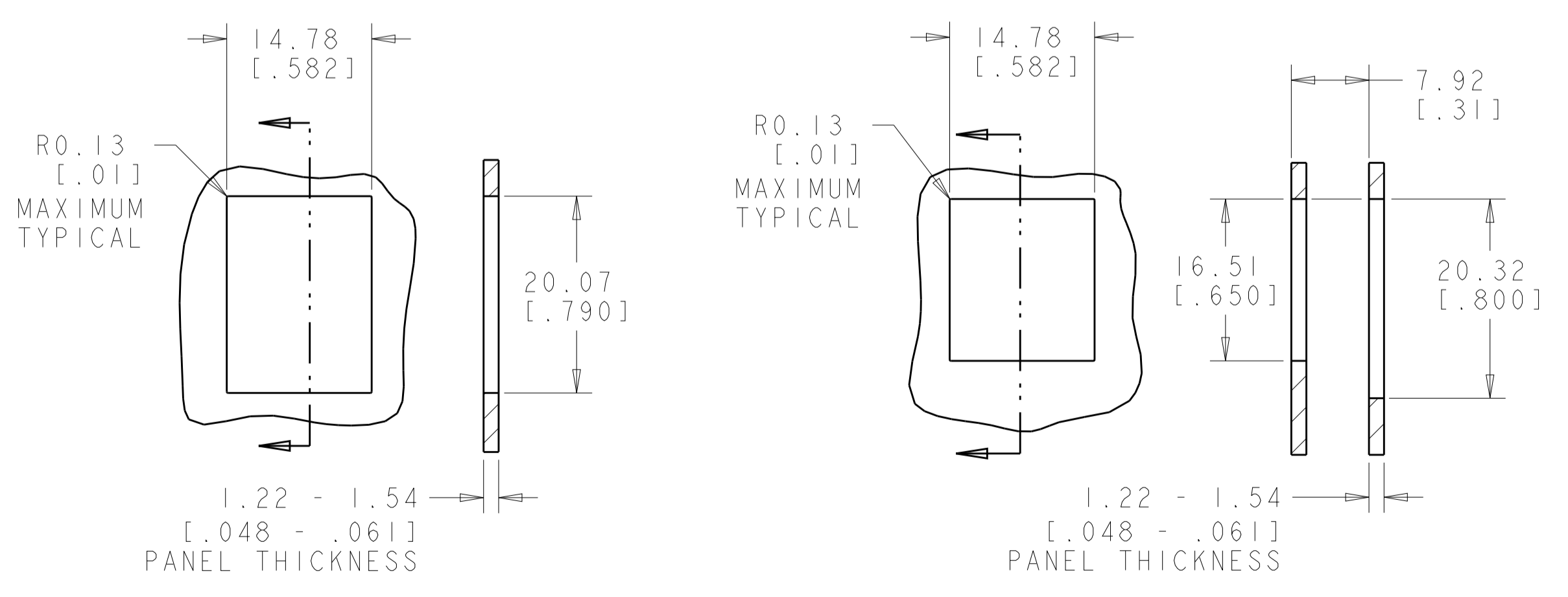

SINGLE PANEL CUTOUT

SUGGESTED FLUSH MOUNT PANEL APPLICATION CUTOUT

ALPINE WHITE	I-1933661-3
LIGHT ALMOND	1933661-1
COLOR	PART NUMBER

THIS DRAWING IS A CONTROLLED DOCUMENT.		DWN: G. GARRETT 11APR2008	ALPINE WHITE		I-1933661-3
DIMENSIONS: MM [INCHES]		CHK: S. ALLGOOD 17APR2008	LIGHT ALMOND		1933661-1
TOLERANCES UNLESS OTHERWISE SPECIFIED:		APVD: S. ALLGOOD 17APR2008	COLOR		PART NUMBER
0 PLC	±	PRODUCT SPEC	USB B-A COUPLER, SL JACK STYLE		
1 PLC	±	APPLICATION SPEC	-		
2 PLC	±	WEIGHT	-		
3 PLC	±	Customer Drawing	-		
4 PLC	±	SCALE	4:1		
ANGLES	±	SHEET	1 OF 1		
MATERIAL	△	REV	C		