



Chipsmall Limited consists of a professional team with an average of over 10 year of expertise in the distribution of electronic components. Based in Hongkong, we have already established firm and mutual-benefit business relationships with customers from,Europe,America and south Asia,supplying obsolete and hard-to-find components to meet their specific needs.

With the principle of “Quality Parts,Customers Priority,Honest Operation,and Considerate Service”,our business mainly focus on the distribution of electronic components. Line cards we deal with include Microchip,ALPS,ROHM,Xilinx,Pulse,ON,Everlight and Freescale. Main products comprise IC,Modules,Potentiometer,IC Socket,Relay,Connector.Our parts cover such applications as commercial,industrial, and automotives areas.

We are looking forward to setting up business relationship with you and hope to provide you with the best service and solution. Let us make a better world for our industry!



Contact us

Tel: +86-755-8981 8866 Fax: +86-755-8427 6832

Email & Skype: info@chipsmall.com Web: www.chipsmall.com

Address: A1208, Overseas Decoration Building, #122 Zhenhua RD., Futian, Shenzhen, China



LOC	DIST	REV	DATE	DWN	APVD
AD	00	B	30APR2012	KH	RP
		REVISIONS			
		DESCRIPTION	DATE	DWN	APVD
		B REVISED PER ECO-12-006575	30APR2012	KH	RP

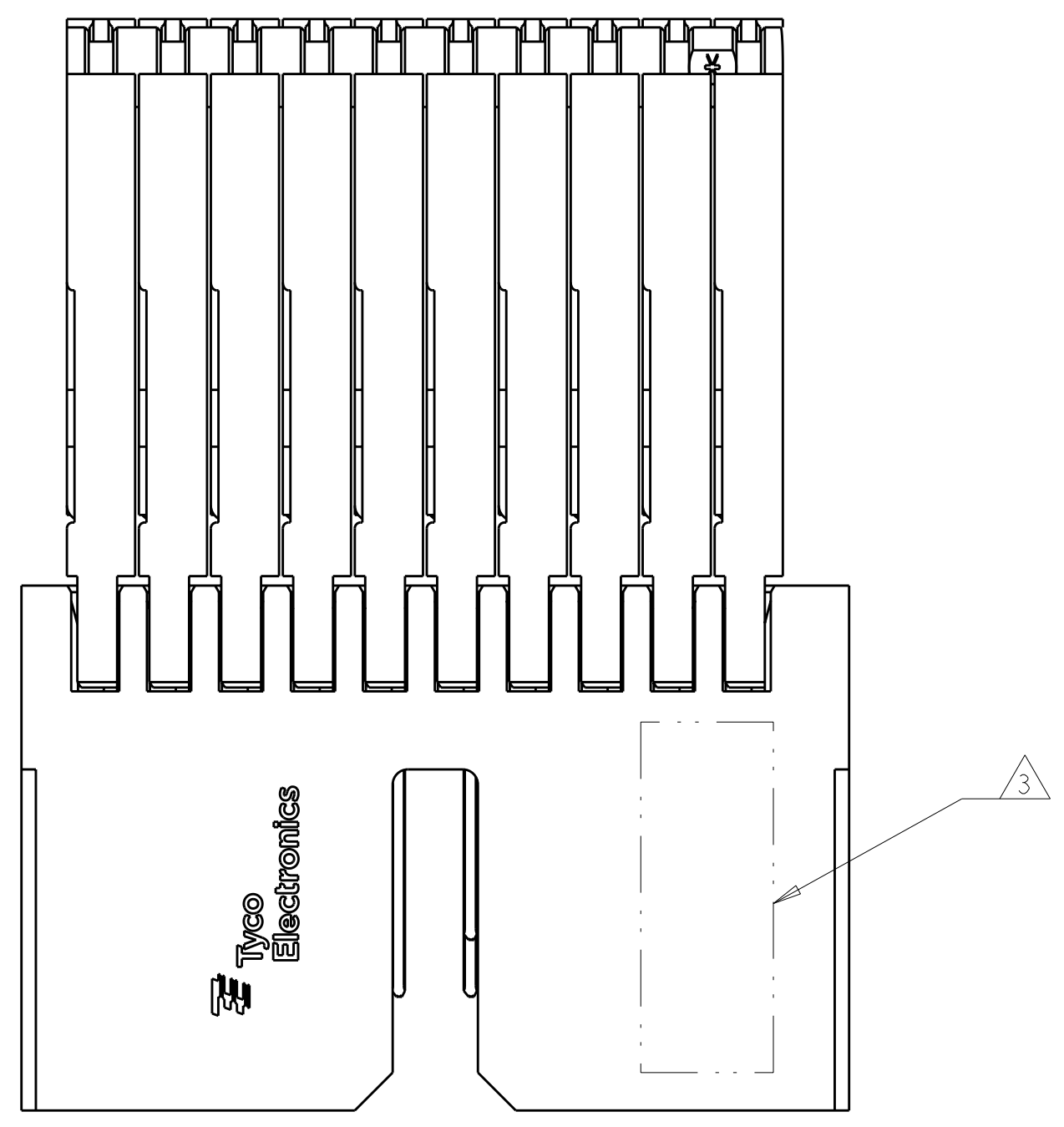
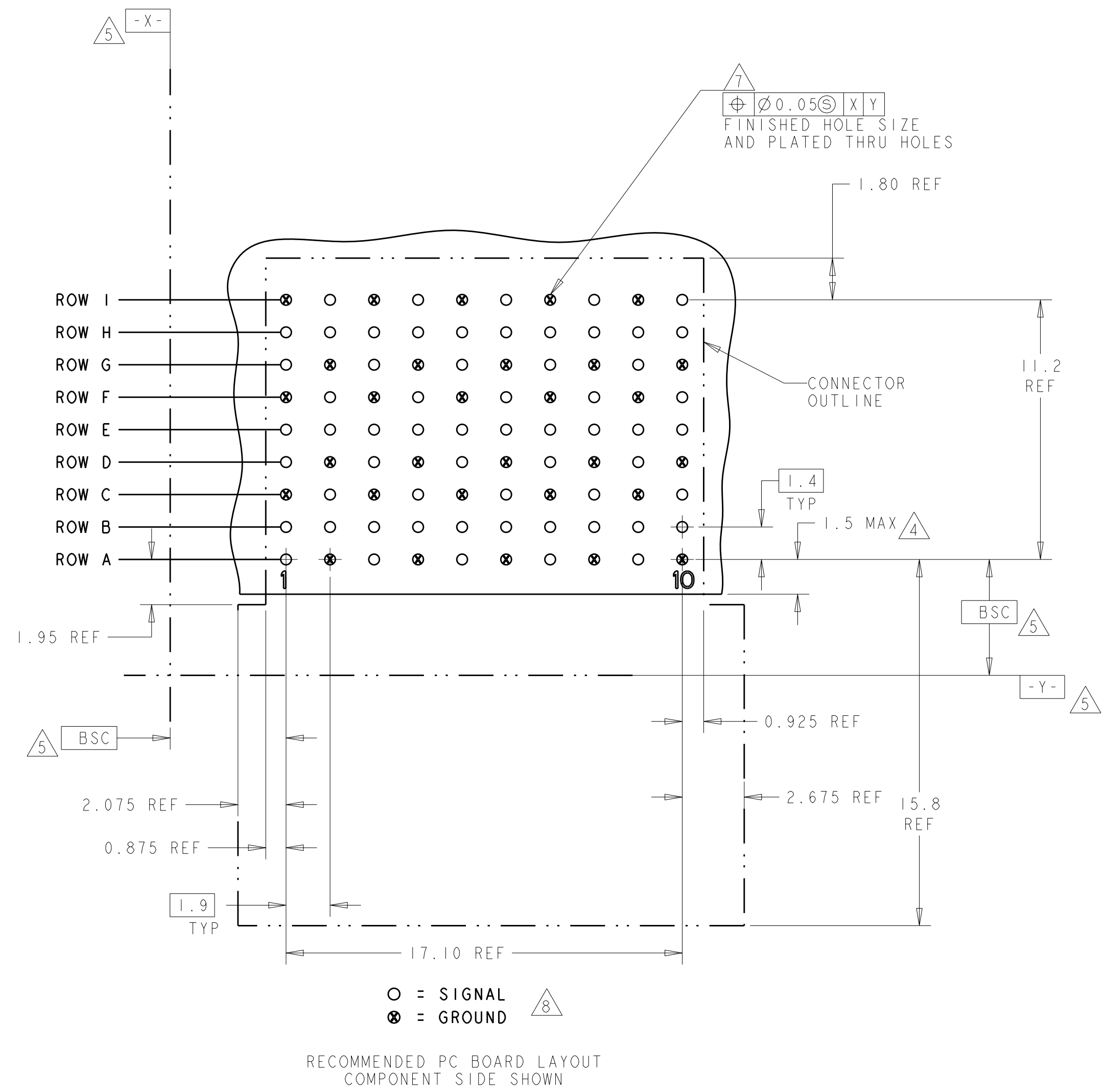

- 1 MATERIAL:
 CONTACT AND SHIELD: PHOS BRONZE
 HOUSING AND CHICKLET: LCP, UL 94V-0, COLOR: BLACK
- 2 FINISH:
 CONTACT AREA FINISH CONFORMS TO THE REQUIREMENTS OF TE PRODUCT SPECIFICATION 108-2303; BASED ON TELCORDIA GR-1217-CORE FOR SYSTEM QUALITY LEVEL III APPLICATIONS IN CONTROLLED ENVIRONMENTS (CENTRAL OFFICE).
- 3 CONNECTOR MARKED WITH PART NUMBER, DATE CODE, 85 OHM, AND STANDARD IN APPROXIMATE AREA SHOWN.
- 4 DIMENSION APPLIES TO CENTERLINE OF THRU HOLE.
- 5 DATUMS AND BASIC DIMENSIONS ESTABLISHED BY CUSTOMER.
- 6 CONTACT AREA LUBRICATED WITH BELLCORE APPROVED LUBRICANT. TECHNICAL REFERENCE: GR-1217-CORE, ISSUE 1, NOVEMBER 1995.
- 7 REFERENCE APPLICATION SPEC FOR RECOMMENDED PLATED THRU HOLE DIAMETER AND PLATING THICKNESS.
- 8 ALL GROUNDS IN ODD NUMBERED COLUMNS ARE COMMONED. ALL GROUNDS IN EVEN NUMBERED COLUMNS, EXCEPT FOR ROW A ARE COMMONED.

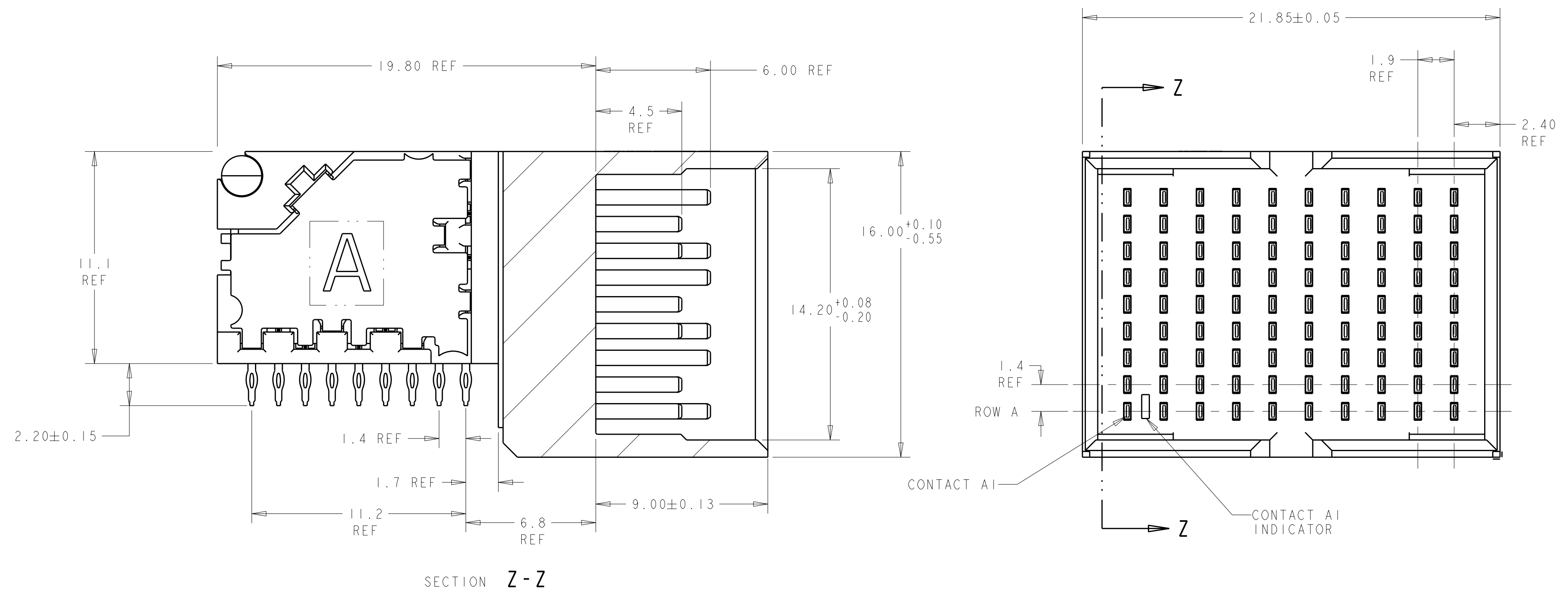

1934950-1
 PART NUMBER

THIS DRAWING IS A CONTROLLED DOCUMENT. DWN W.SOURBEER 01MAY2008
 CHK C.RITIER 01MAY2008

STE TE Connectivity

NAME: RIGHT ANGLE HEADER ASSEMBLY, DOUBLE WALL, 3 PAIR, 10 COLUMN, Z-PACK TinMan

PRODUCT SPEC: 108-2303-1
 APPLICATION SPEC: 114-13243

SIZE: A100779 C=1934950
 WEIGHT: -

CUSTOMER DRAWING SCALE: 6:1 SHEET 1 OF 1 REV B