



Chipsmall Limited consists of a professional team with an average of over 10 year of expertise in the distribution of electronic components. Based in Hongkong, we have already established firm and mutual-benefit business relationships with customers from,Europe,America and south Asia,supplying obsolete and hard-to-find components to meet their specific needs.

With the principle of “Quality Parts,Customers Priority,Honest Operation,and Considerate Service”,our business mainly focus on the distribution of electronic components. Line cards we deal with include Microchip,ALPS,ROHM,Xilinx,Pulse,ON,Everlight and Freescale. Main products comprise IC,Modules,Potentiometer,IC Socket,Relay,Connector.Our parts cover such applications as commercial,industrial, and automotives areas.

We are looking forward to setting up business relationship with you and hope to provide you with the best service and solution. Let us make a better world for our industry!



Contact us

Tel: +86-755-8981 8866 Fax: +86-755-8427 6832

Email & Skype: info@chipsmall.com Web: www.chipsmall.com

Address: A1208, Overseas Decoration Building, #122 Zhenhua RD., Futian, Shenzhen, China



Digital Hand-Held Static Fieldmeter Operation and Maintenance



Made in America

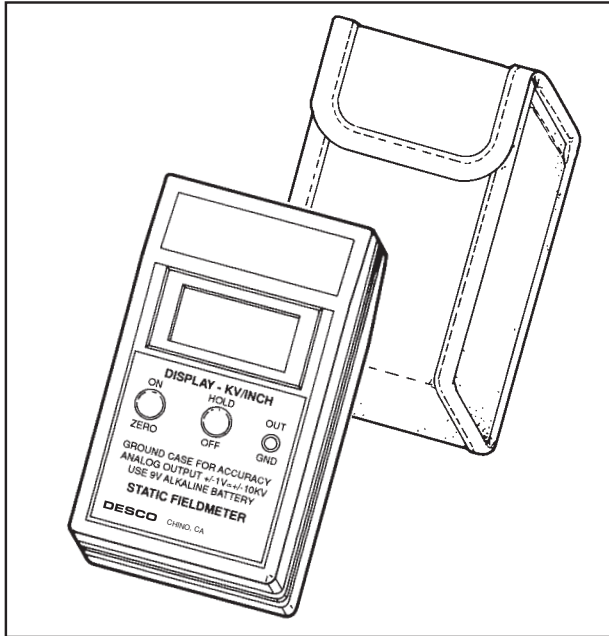

Figure 1. 19445 Digital Static Fieldmeter

Description

The Desco 19445 is a high quality, portable non-contacting static fieldmeter which produces consistently accurate readings with ease and provides years of trouble-free operation. It indicates surface voltage and polarity on objects up to $\pm 20\text{kV}$ at a spacing of one inch with an accuracy of 5% of the displayed value. It is chopper-stabilized for use under almost any conditions including ionized environments. Also featured are a push-button auto-zero and a push-button hold function. A unique flashing LED rangefinder system provides accurate positioning of the meter from the target.

Its accuracy is dependent upon four factors:

- Grounding of the meter via a ground cord or a grounded operator.
- The instrument must be properly zeroed.
- The distance from the front edge of the case to the target or surface under examination must be accurately defined.
- The target must be large relative to the measurement distance. It should be at least 5" x 5" for true accuracy.

Inspection

Remove the fieldmeter from the carton and inspect for damage. Included with each unit should be:

- 1 carrying case
- 1 9V alkaline battery

Operation

ZEROING THE METER

1. The meter needs only to be zeroed at the time you first use the instrument. It will maintain this value until the battery is changed.
2. Press the ON/ZERO button and release. The LCD display is activated and LED rangefinder lights begin to flash.
3. Ground the operator by using a wrist strap or a footgrounding device. You can also ground the unit directly via a ground cord. The case of the instrument is conductive and is the reference for the measurement.
4. Face the Fieldmeter away from charged objects and press the ON/ZERO button. Hold until the display reads zero. The instrument may also be zeroed by pointing it toward a known grounded surface (such as the palm of the opposite hand) and depressing the ON/ZERO button. Although you must be careful not to contact the recessed sensor plate, the amount of spacing between the instrument and the target is not critical when zeroing the instrument.

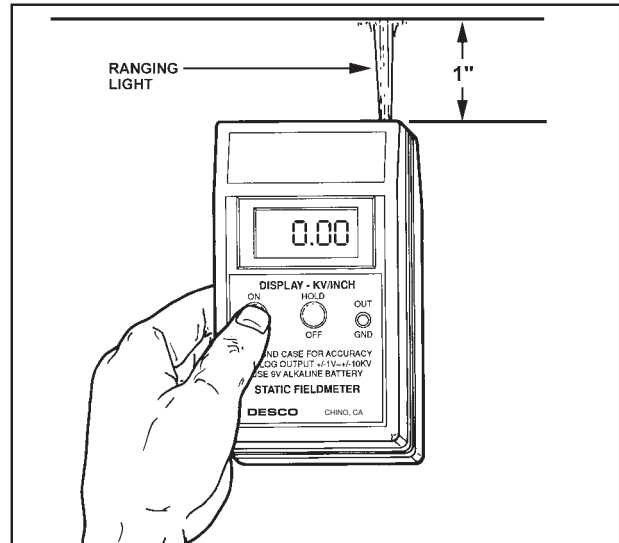

Figure 2. Zeroing the meter.

TAKING READINGS

1. Point the sensor plate toward the target and move to a spacing of one inch from sensor plate to target. Use the LED rangefinder to determine this distance. The two LEDs appear to form a stationary (not moving) circle on the target at one inch. Note the meter reading. A source with a negative polarity shows a minus (-) sign in the display. A positive source will display no sign.

To hold the reading, click the HOLD/OFF button briefly. The present reading is held and the word "HOLD" appears in the display. The rangefinder LEDs go off during the hold period to

conserve battery life. A second brief click releases the held reading.

CAUTION: If, as you approach the target, the indicated field strength begins to exceed 20kV at a distance greater than 1", **STOP!** This implies that the target voltage may be high enough to create an arc. Proceed with caution.

For measurements in excess of 20kV, estimate the distance to the target and use the following multiplying factors:

At 4", multiply reading by 2 - 40kV range
At 6.5", multiply reading by 3 - 60kV range
At 8.5", multiply reading by 4 - 80kV range

The LED rangefinder system is calibrated at 1" distance only.

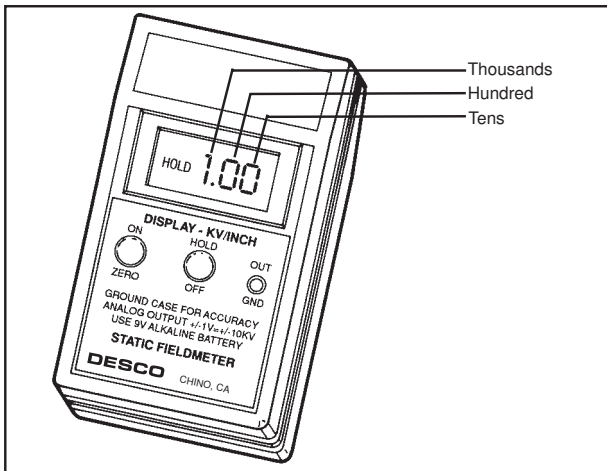

Figure 3. Taking readings in the "HOLD" mode.

2. Repeat the above for additional measurements.
3. To turn the instrument off, press and hold the HOLD/OFF button for more than 3 seconds.

AUTO SHUTDOWN TIMER

During normal operation (not during ZERO) a blinking decimal point indicates the AUTO SHUTDOWN TIMER is enabled. If the AUTO SHUTDOWN TIMER is disabled the decimal point will be on continuously.

Holding down the ZERO button, while unit is ON, for less than 3 seconds resets the AUTO SHUTDOWN TIMER (if enabled). The AUTO SHUTDOWN TIMER is enabled or disabled by turning on the unit and keeping the ON/ZERO button pressed then toggling the HOLD/OFF button. Enable/disable of the AUTO SHUTDOWN TIMER is indicated by the decimal point: DP on = timer on, DP off = timer off.

AUTO SHUTDOWN TIMER state is maintained during power off. AUTO SHUTDOWN TIMER can be continually toggled as long as the ON/ZERO button remains pressed, up to 20 seconds, after which the unit will turn off. A blinking decimal point indicates the AUTO SHUTDOWN TIMER is active. During the last minute before

power off ALL annunciators will blink at a fast rate. Pressing any button will reset the timer. Timeout is nominally 15 minutes.

Operating Notes:

- The case of the instrument is made of a material which is sufficiently conductive to provide a grounding path via the person holding the instrument or a grounded wrist strap in contact with the case.
- The output jack accepts a standard 3/32" (2.5mm) monaural phone plug and is provided in order that the output of the instrument may be connected to an oscilloscope, strip chart recorder, external meter or other device. The output voltage at this jack is ± 2 volts for full input (20kV/in. at 1") for high impedance loads (100 k Ω or greater). It has an impedance of approximately 100 Ω .

The shell of this jack may be used to provide a "hard ground" connection.

- If you press the on/zero button during operation, the meter begins the auto zero function and displays the value. If you do not complete the auto zero operation, the meter is not correctly zeroed.
- For extended monitoring of materials, a +9 volt power supply (such as Radio Shack #273-1552) may be substituted for the battery.

Measurement Accuracy

The accuracy of measurement is dependent on a stable ground reference and the 1 inch measuring distance as previously noted. It is also dependent on the "aspect ratio," relating the size of the object to be measured to the measurement distance. This ratio should be at least 3 for best accuracy, i.e. the object should be at least a 3 inch square when measuring at a 1 inch distance. Accurate measurements may be made at other measurement distances by scaling the meter range and observing the proper aspect ratio. For example, at a measurement distance of 3 inches, the object being measured at this distance should be at least a 9 inch square.

Auditing of Ionization Equipment with the 19445

Due to its unique measuring circuit the digital fieldmeter will accurately operate in an ionized air stream or ionized field.

Desco offers a "Portable Ionization Test Kit" (Item #19447) designed to facilitate routine auditing and periodic testing of ionization equipment. The test kit is designed to be used in conjunction with the 19445 meter. The meter and test kit combination can be used to audit an ionizer's overall performance. The highly portable test kit allows the user to make quick and accurate balance level and neutralization efficiency measurements. The test kit is sold separately as item #19447. The Portable Ionization Test Kit includes a slide-on adapter plate, a ± 1000 V charging unit and a durable molded carrying case along with the Digital Fieldmeter.

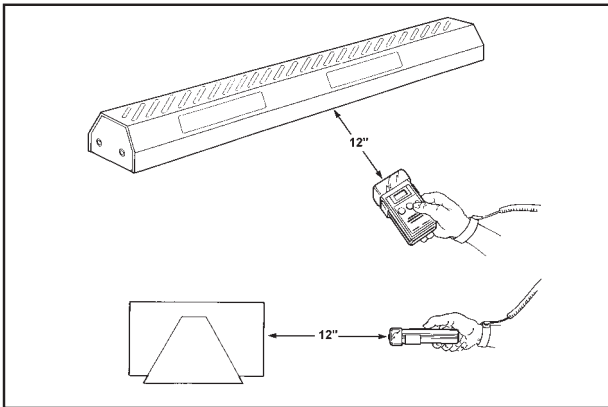

Figure 4. Auditing ionization equipment with the Digital Fieldmeter and the Ionization Test Kit.

In order to test ionization equipment to an industry recognized standard, we recommend the test procedure published by the ESD Association as Standard 3.1. This standard may be obtained from the ESD Association, 7902 Turin Road, Suite 4, Rome, NY 13440-2069, (315) 339-6937.

Maintenance

BATTERY REPLACEMENT

The unit should be off while replacing the battery. Normal battery life is about 40 hours of use. Replace the battery when the "BAT" indicator appears in the display above the "HOLD" indicator position for more than an instant or change at least once a year. Dead battery voltage is approximately 7.2 volts.

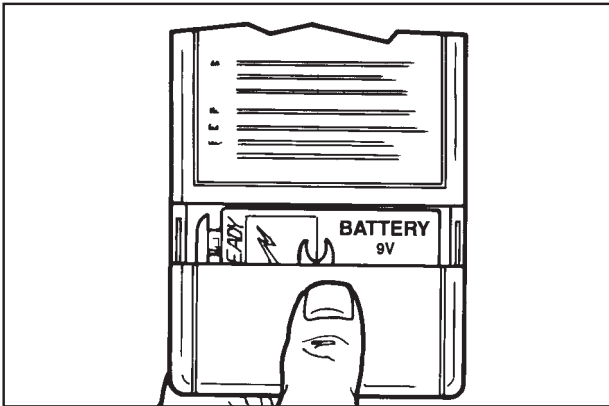

Figure 5. Replacing batteries.

Replacement type is Eveready #216 or equivalent NEMA 1604. An alkaline type is recommended where longest service life is important. Remove the battery when storing the instrument for an extended period of time.

NOTE: After you change the battery you will need to re-zero the meter.

CLEANING

If the 19445 is used in a dirty or dusty environment, it may be necessary to clean the sensor to ensure proper operation.

Foreign materials which may enter the aperture associated with the input electrode can generate undesired signals, offset or drift, thereby impairing the accuracy and utility of the instrument. It is imperative that the area around the aperture be kept scrupulously clean at all times. This can best be done by proper care, handling and storage of the instrument. Loose dust or other particulate matter may simply be blown away with low pressure instrument grade air.

More severe contamination may be removed by spraying or flushing with the least practical amount of clean technical grade isopropyl alcohol. Stand with instrument on end and allow to dry thoroughly for several hours. Cleaning with any solvent should **NOT** be done on a routine basis.

Calibration

The Desco 19445 is calibrated prior to shipment to NIST traceable standards. Re-calibration should be performed annually unless the instrument has been tampered with or repaired, or more frequent calibration is specified by company policy or by contract. Calibration of the Digital Field Meter should only be performed by the factory. Contact our Customer Service Department for details.

Recommended Reading

SEMI E43-95, RECOMMENDED PRACTICE FOR MEASURING STATIC CHARGE ON OBJECTS AND SURFACES. Published by Semiconductor Equipment Materials International (SEMI), Mountain View, CA, (650) 964-5111.

Specifications

| | |
|---------------------|---|
| Display: | 3 1/2 digits, 0.4" digit height LCD |
| Response: | <1 sec., 10% to 90% equivalent to 5Hz output |
| Range: | ± 0.00 to ± 19.99 kV/inch (25mm) |
| Accuracy: | ± 5% of displayed value, ± 3 counts (LSD) |
| Environment: | 0 - 50°C at 85% RH (non- condensing) |
| Output: | 2.5mm phone jack/plug, ± 2 volts for full input (2V/20kV/in.) |
| Battery: | 9 volt, NEMA 1604, alkaline recommended |
| Accessories: | Carrying case and technical bulletin included |

Charged Plate Adapter available as an optional accessory for testing air ionizers

Personal HBM Test Fixture

(Requires the 19449 Charging Plate to be installed first)

The Personal HBM Test Fixture (Desco Item Number 19448) turns your model 19445 Digital Field Meter into a Human Body Model tribo-electric charging tester. This kit will allow you to measure electrical charges generated on the human body while walking or moving across an insulative or conductive surface. It has been specially designed to measure static charges produced by walking across substrates such as carpeting, vinyl floor tile, and sealed concrete. It can also be used to detect charge generation on conductive surfaces such as conductive or dissipative floor tiles

and carpeting. An ESD technician may also use this tool to verify proper grounding between a conductive or dissipative floor surface and a person wearing personal grounding devices such as foot grounders. The amount (or size) of the charge generated will vary from one human body to another. Other factors such as humidity, contamination between the foot and flooring surface, as well as human body capacitance will also affect the amount of charge generated.

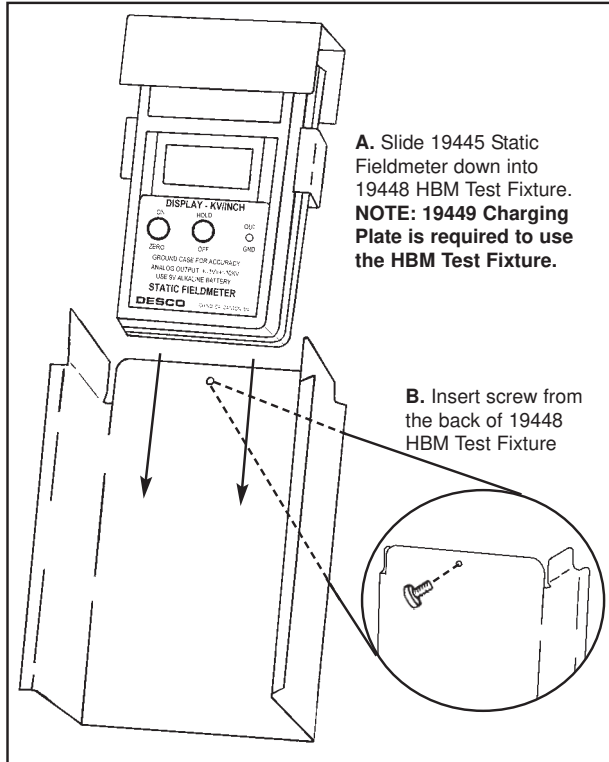

Figure 6. Installing HBM Test Fixture on 19445 Digital Field Meter

INSTALLATION AND REMOVAL

The test fixture is stored in the Survey Kit with the Digital Field Meter installed, ready for use. Or, you may purchase the 19448 HBM Test Fixture and 19449 Charging Plate separately if you don't have a Survey Kit. If the fixture needs to be removed to allow use of the Field Meter alone, follow steps A and B of the diagram. The ground cord is located underneath the test fixture in the Survey Kit. To obtain the desired result, the ground cord must be installed onto the Field Meter and attached to a utility or common ground point.

METHOD OF OPERATION

In order to obtain the desired test results, the meter must be properly grounded as stated in the Installation and Removal section. Once installed on the Field Meter, the Test Fixture itself is isolated from the meter case and ground and should remain that way.

Cradle the Test Fixture in the palm of your hand. Once the meter is grounded and you are standing on the substrate to be tested, simply walk around, shuffle your feet or raise a foot, to determine if the combination of footwear and substrate produces an electrical charge. If an electrical charge is generated and induced onto the

human body, the Test Fixture will transfer that charge onto the Field Meter, and the amount of the charge will be registered. If it is necessary to record the amount of charge, you can save

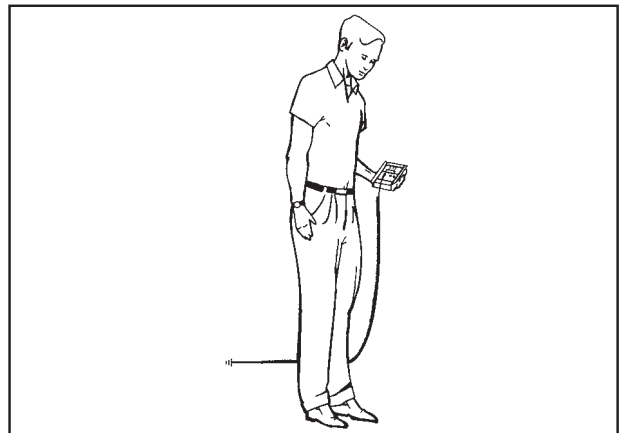

Figure 7. Using the HBM Test Fixture to measure charges on the body.

the result by simply pressing the Hold button on the front of the Field Meter, and pressing the button with an insulated object. This test can be done regardless of the type of footwear or substrate combination. Other items in your ESD Control Program may also be tested such as conductive or dissipative chairs. Simply sit in the chair on the desired substrate and move the chair back and forth to determine if the chair and human body combination produces and electrical charge.

Limited Warranty

Desco expressly warrants that for a period of one (1) year from the date of purchase, Desco Static Fieldmeters will be free of defects in material (parts) and workmanship (labor). Within the warranty period, the product will be tested, repaired, or replaced at Desco's option, free of charge. Call our Customer Service Department at 909-627-8178 (Chino, CA) or 781- 821-8370 (Canton, MA) for a Return Material Authorization (RMA) and proper shipping instructions and address. Include a copy of your original packing slip, invoice, or other proof of purchase date. Any unit under warranty should be shipped prepaid to the Desco factory. Warranty repairs will take approximately two weeks.

If your unit is out of warranty call Customer Service at 909-627-8178 (Chino, CA) or 781-821-8370 (Canton, MA) for a Return Material Authorization (RMA) and proper shipping instructions and address. Desco will quote repair charges necessary to bring your unit up to factory standards.

Warranty Exclusions

THE FOREGOING EXPRESS WARRANTY IS MADE IN LIEU OF ALL OTHER PRODUCT WARRANTIES, EXPRESSED AND IMPLIED, INCLUDING MERCHANTABILITY AND FITNESS FOR A PARTICULAR PURPOSE WHICH ARE SPECIFICALLY DISCLAIMED. The express warranty will not apply to defects or damage due to accidents, neglect, misuse, alterations, operator error, or failure to properly maintain, clean or repair products.

Limit of Liability

In no event will Desco or any seller be responsible or liable for any injury, loss or damage, direct or consequential, arising out of the use of or the inability to use the product. Before using, users shall determine the suitability of the product for their intended use, and users assume all risk and liability whatsoever in connection therewith.