



Chipsmall Limited consists of a professional team with an average of over 10 year of expertise in the distribution of electronic components. Based in Hongkong, we have already established firm and mutual-benefit business relationships with customers from,Europe,America and south Asia,supplying obsolete and hard-to-find components to meet their specific needs.

With the principle of “Quality Parts,Customers Priority,Honest Operation,and Considerate Service”,our business mainly focus on the distribution of electronic components. Line cards we deal with include Microchip,ALPS,ROHM,Xilinx,Pulse,ON,Everlight and Freescale. Main products comprise IC,Modules,Potentiometer,IC Socket,Relay,Connector.Our parts cover such applications as commercial,industrial, and automotives areas.

We are looking forward to setting up business relationship with you and hope to provide you with the best service and solution. Let us make a better world for our industry!



Contact us

Tel: +86-755-8981 8866 Fax: +86-755-8427 6832

Email & Skype: info@chipsmall.com Web: www.chipsmall.com

Address: A1208, Overseas Decoration Building, #122 Zhenhua RD., Futian, Shenzhen, China



Dual-Wire Dual-Operator Programmable Monitor Installation, Operation and Maintenance



Made in the
United States of America



Figure 1. Desco 19665 Dual-Wire Dual-Operator Programmable Monitor

Description

The patented* Desco Dual-Wire Dual-Operator Programmable Monitor monitors two operators and two ESD work surfaces eliminating the need for periodic testing and record keeping of wrist straps. The Dual-Wire Dual-Operator Programmable Monitor uses low-voltage steady state DC continuous-loop technology to continuously monitor (versus pulsed or intermittent) dual-wire wrist strap functionality. Independent audio and visual alarm conditions make it easy to identify the status of the work surfaces and operators. Two operator remotes with 10 foot cables are included for use at adjacent workstations. Each monitor is calibrated with accepted procedures and standards traceable to the National Institute of Standards and Technology (NIST) and includes a NIST certificate.

ANSI/ESD S20.20 section 7.3 states “Compliance verification records shall be established and maintained to provide evidence of conformity to the technical requirements.”

Per ANSI/ESD S1.1 Annex A.3 Daily (wrist strap system) testing may be omitted if constant monitoring used.” Per ESD Handbook ESD TR 20.20 section 5.3.2.4.4 “Typical Test programs recommend that wrist straps that are used daily should be tested daily. However, if the products that are being produced are of such value that knowledge of a continuous, reliable ground is needed, and then continuous monitoring should be considered or even required.”

Packaging

- 1 Dual-Wire Dual-Operator Programmable Monitor
- 1 Power Adapter, 12VDC, N. America
- 2 Operator Remotes
- 2 Operator Remote Cables (1 black, 1 white)
- 2 Mat Monitor Cords (1 black, 1 white)
- 2 Mat Ground Cords (green and yellow)
- 1 Monitor Ground Cord (green and yellow)
- 1 Universal Snap Kit
- 1 Certificate of Calibration

*U.S. Patents 6,052,053 and 6,205,408

Features and Components

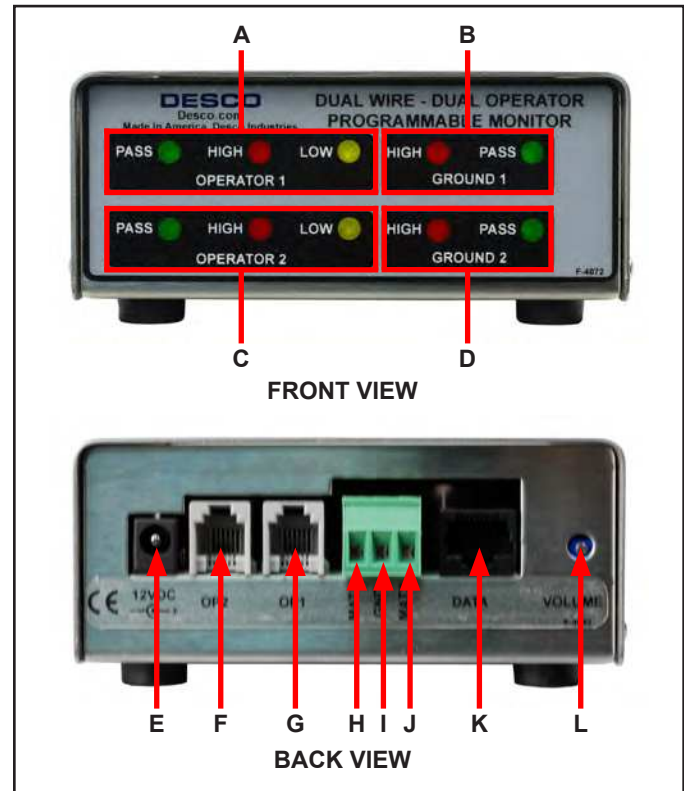

Figure 2. Dual-Wire Dual-Operator Programmable Monitor features and components

A. Operator 1 Status LEDs: When the green LED is illuminated, operator 1 is properly grounded. When the LED is illuminated red or yellow and the alarm sounds, operator 1 is not properly grounded.

B. Worksurface 1 Status LEDs: When the green LED is illuminated, worksurface 1 is properly grounded. When the red LED is illuminated and the alarm sounds, worksurface 1 is not properly grounded.

C. Operator 2 Status LEDs: When the green LED is illuminated, operator 2 is properly grounded. When the LED is illuminated red or yellow and the alarm sounds, operator 2 is not properly grounded.

D. Worksurface 2 Status LEDs: When the green LED is illuminated, worksurface 2 is properly grounded. When the LED is illuminated red and the alarm sounds, worksurface 2 is not properly grounded.

E. Power Jack: Connect to the included 12VDC power adapter.

F. Operator 2 Remote Jack: Connect to the black operator remote cable.

G. Operator 1 Remote Jack: Connect to the white operator remote cable.

H. Monitored Mat 1 Terminal: Monitors a worksurface mat for proper dissipative resistance and static charges. Connect the white mat monitor cord here.

I. Ground Terminal: Common ground point for the monitor. Connect to the green and yellow monitor ground cord.

J. Monitored Mat 2 Terminal: Monitors a worksurface mat for proper dissipative resistance and static charges. Connect the black monitor cord here.

K. Data Output: To be used with the EMIT 50476 Smart Hub and EMIT SIM Software for automated record keeping of the monitor's performance. [Click here](#) to learn more about the EMIT SIM Software.

L. Alarm Audible Adjustment: Turn the trimpot clockwise to increase the audible alarm volume and counter-clockwise to decrease it.

Installation

1. Determine the mounting location of the Dual-Wire Dual-Operator Monitor. The front panel should be visible to both operators.
2. Determine the mounting locations of the operator remotes. Be sure to install the remotes at a distance that enables the 10 foot leads to reach the back of the monitor.
3. Install tinned wire ends of the mat cords to their appropriate screw terminal block located at the back of the monitor.
4. Attach the worksurface mats to ground using the green mat ground cord. Install the ring terminal end of the cord to an appropriate ground point. Attach the snaps terminals to the snaps on the worksurface mat.
5. Install the tinned wire end of the green and yellow monitor ground cord to the ground terminal located at the back of the monitor. Install its ring terminal to an appropriate ground point. Be sure to use a different ground point than the one used for the mats. The face plate screw of a grounded AC wall outlet may provide a convenient connection point.
6. Route the mat cords from the back of the monitor to the snaps on worksurface mats. The white cord is for worksurface mat #1. The black cord is for worksurface mat #2.
7. Insert the operator remote cables into their appropriate jacks located at the back of the monitor. The white cable is for operator #1. The black cable is for operator #2.
8. Connect the power adapter to the power jack located at the back of the monitor. Plug the power adapter into a proper AC power outlet. The monitor is now powered.

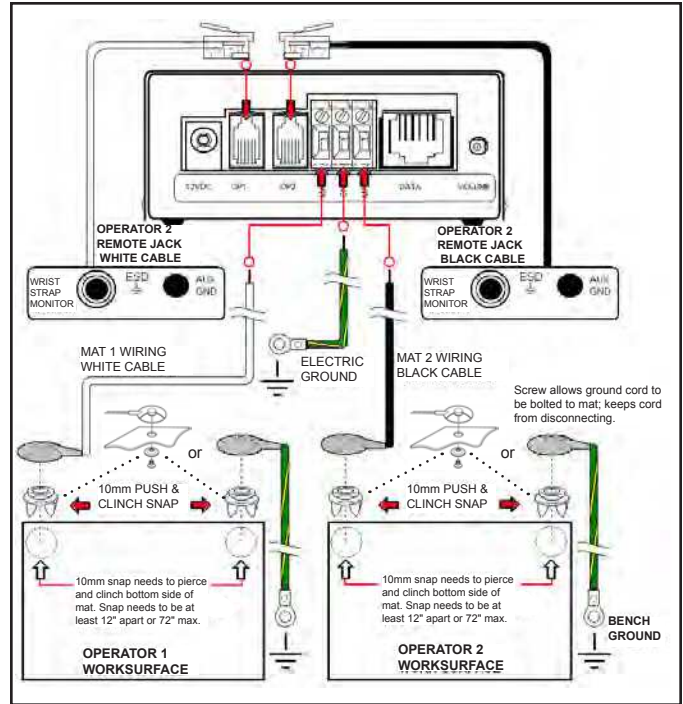

Figure 3. Installing the Dual-Wire Dual-Operator Programmable Monitor

Operation

1. Monitoring of the operators will remain in the STANDBY condition until a wrist cord is plugged into the operator remote. STANDBY mode is indicated by a blinking yellow operator LED.
2. Plug a wrist strap cord, not attached to the wristband, into the monitored jack labeled WRIST STRAP MONITOR located on the remote. This automatically activates the selected operator channel. The corresponding operator LED should illuminate red and the alarm should sound on the monitor.
3. Remove the charges from your body by making contact with a properly grounded ESD worksurface.
4. Snap the cord to the wristband, and fit it snugly onto your wrist. This should silence the audible alarm and cause the corresponding operator LED to switch from red to green. If this does not happen, examine the wrist cord for continuity or damage and your wrist band to ensure that it is securely fit. If you have dry skin, apply an approved dissipative hand lotion such as [Menda Reztore™ ESD Hand Lotion](#).
5. The AUX GND jack located on the operator remote is a grounded and unmonitored connection for guests. It must be used with a banana plug wrist cord and single-wire wristband.

NOTE: Worksurface must have a conductive layer such as Dual Layer Rubber or Dissipative 3-Layer Vinyl or Micastat® Dissipative Laminate with conductive buried layers. EMIT Continuous Monitors are not recommended for use with homogeneous matting.

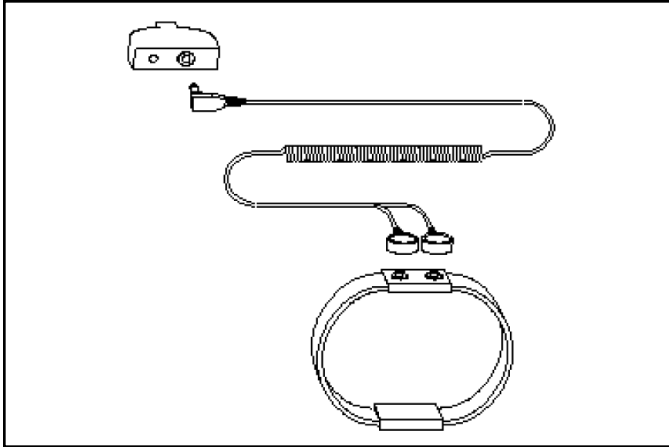

Figure 4. Connecting a dual-wire wrist strap to the operator remote

SETTING THE OPERATOR TEST VOLTAGE AND TEST LIMIT

The Dual-Wire Dual-Operator Monitor's operator test voltage and high test limit can be set to different values. The operator test voltage can be set to either +5V or +8V, and the operator high test limit can be set to either 10 megohms or 35 megohms. The default voltage is +8V, and the default operator high test limit is 10 megohms. These settings are controlled by a set of 3 switches located inside the monitor's enclosure.

NOTE: Desco recommends re-calibration of the monitor should either setting be changed. See the "Calibration" section for more information.

To gain access to these switches, remove the monitor's cover and position the monitor so the PCB matches the orientation shown in Figure 5. Switches SW1 and SW2 control the operator test voltage. Switch SW3 controls the operator high test limit.

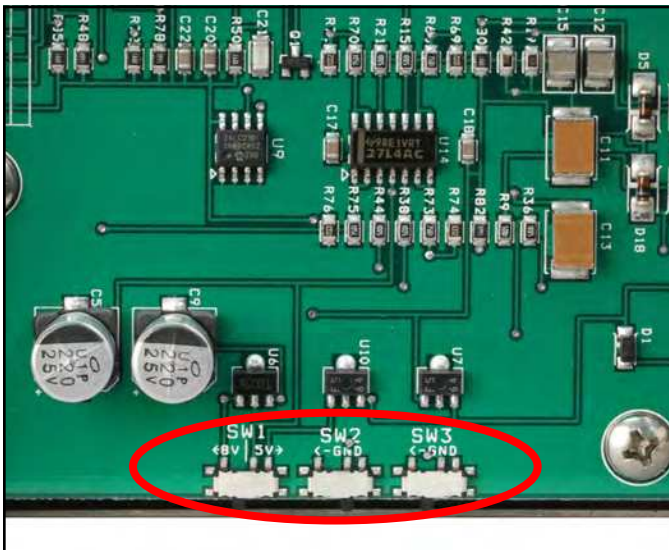

Figure 5. Switches SW1, SW2 and SW3 inside the monitor's enclosure

Operator Test Voltage

+5V

SW1 Position: RIGHT

SW2 Position: LEFT

+8V

SW1 Position: LEFT

SW2 Position: RIGHT

Operator High Test Limit

10 megohms

SW3 Position: RIGHT

35 megohms

SW3 Position: LEFT

Calibration

The Dual-Wire Dual-Operator Programmable Monitor is calibrated to standards traceable to NIST. Frequency of recalibration should be based on the critical nature of those ESD sensitive items handled and the risk of failure for the ESD protective equipment and materials. In general, we recommend that calibration be performed annually.

Use the EMIT [50524](#) Limit Comparator for Dual-Wire Monitors to perform periodic testing (once every 6-12 months) of the Dual-Wire Dual-Operator Programmable Monitor. The Limit Comparator can be used on the shop floor within a few minutes virtually eliminating downtime, verifying that the monitor is operating within tolerances.

See [TB-6542](#) for more information.



Figure 6. EMIT [50524](#) Limit Comparator for Dual-Wire Monitors

NIST Calibration

Desco provides a basic, National Institute of Standards and Technology (NIST) traceable calibration for the products that we manufacture. This is sometimes referred to as a Level 1 calibration.

For more on National Institute of Standards and Technology see:

<http://www.nist.gov/index.html>

For more information on the calibration that Desco's provides for products that we manufacture see:

<http://desco.descoindustries.com/Calibration.aspx>

Specifications

Operating Voltage	12 VDC
Operating Temperature	32°F - 104°F (0 - 40°C)
Monitor Dimensions	4.4" x 4.7" x 2.1" (11.2cm x 11.9cm x 5.3cm)
Monitor Weight	1.1 lbs (0.5 kg)

TEST VOLTAGES

Operator	+8 V** or +5 V
Worksurface	200 mV

TEST LIMITS

Operator	Low Fail: < 1.72 megohms Pass: 2 - 9 megohms** High Fail: > 11.5 megohms** or Pass: 2 - 30 megohms High Fail: > 40 megohms
Worksurface	Pass: < 3.5 megohms Fail: > 3.8 megohms

**Default

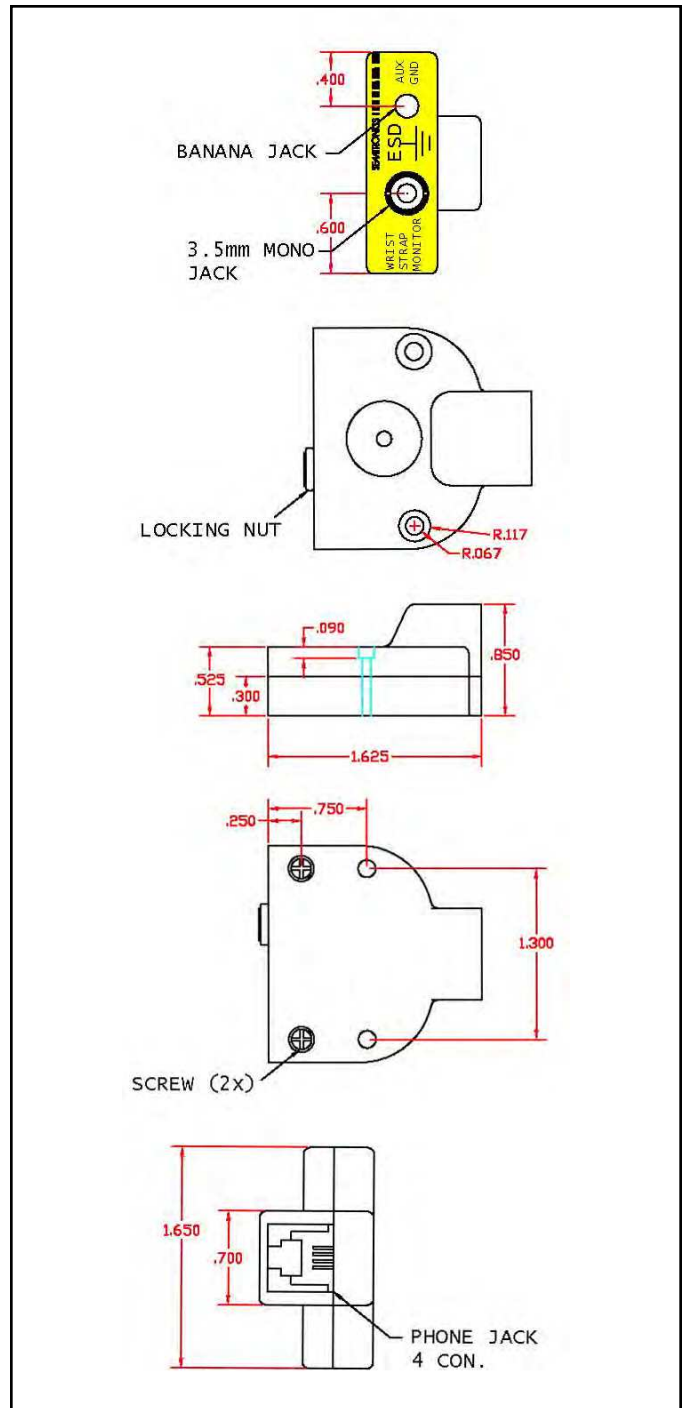

Figure 7. Operator Remote dimensions

Replacement remotes are available as EMIT item numbers [50525](#) and [50526](#).

Limited Warranty

Desco expressly warrants that for a period of one (1) year from the date of purchase Desco Continuous Monitors will be free of defects in material (parts) and workmanship (labor). Within the warranty period, a credit for purchase of replacement Desco Continuous Monitor, or, at Desco's option, the Ionizer Motion Sensor will be repaired or replaced free of charge. If product credit is issued, the amount will be calculated by multiplying the unused portion of the expected one year life times the original unit purchase price. Call our Customer Service Department at 909-627-8178 (Chino, CA) or 781-821-8370 (Canton, MA) for a Return Material Authorization (RMA) and proper shipping instructions and address. Please include a copy of your original packing slip, invoice, or other proof of date of purchase. Any unit under warranty should be shipped prepaid to the Desco factory. Warranty replacements will take approximately two weeks.

If your unit is out of warranty, call our Customer Service Department at 909-627-8178 (Chino, CA) or 781-821-8370 (Canton, MA) for a Return Material Authorization (RMA) and proper shipping instructions and address. Desco will quote repair charges necessary to bring your unit up to factory standards.

Warranty Exclusions

THE FOREGOING EXPRESS WARRANTY IS MADE IN LIEU OF ALL OTHER PRODUCT WARRANTIES, EXPRESSED AND IMPLIED, INCLUDING MERCHANTABILITY AND FITNESS FOR A PARTICULAR PURPOSE WHICH ARE SPECIFICALLY DISCLAIMED. The express warranty will not apply to defects or damage due to accidents, neglect, misuse, alterations, operator error, or failure to properly maintain, clean or repair products.

Limit of Liability

In no event will Desco or any seller be responsible or liable for any injury, loss or damage, direct or consequential, arising out of the use of or the inability to use the product. Before using, users shall determine the suitability of the product for their intended use, and users assume all risk and liability whatsoever in connection therewith.