



Chipsmall Limited consists of a professional team with an average of over 10 year of expertise in the distribution of electronic components. Based in Hongkong, we have already established firm and mutual-benefit business relationships with customers from,Europe,America and south Asia,supplying obsolete and hard-to-find components to meet their specific needs.

With the principle of "Quality Parts,Customers Priority,Honest Operation,and Considerate Service",our business mainly focus on the distribution of electronic components. Line cards we deal with include Microchip,ALPS,ROHM,Xilinx,Pulse,ON,Everlight and Freescale. Main products comprise IC,Modules,Potentiometer,IC Socket,Relay,Connector.Our parts cover such applications as commercial,industrial, and automotives areas.

We are looking forward to setting up business relationship with you and hope to provide you with the best service and solution. Let us make a better world for our industry!



## Contact us

Tel: +86-755-8981 8866 Fax: +86-755-8427 6832

Email & Skype: info@chipsmall.com Web: www.chipsmall.com

Address: A1208, Overseas Decoration Building, #122 Zhenhua RD., Futian, Shenzhen, China



DATE: 2016-2-18 (YY/MM/DD)

Customer :

# APPROVAL SHEET

PRODUCT: AC ADAPTOR

MODEL: GEO151UB-6025

PART NO. C688-13917

V: A1

Receiver's stamp or signature

PLEASE APPROVE & RETURN BEFORE 2016-2-21  
OR WE WOULD REGARD IT BEEN CONFIRMED.

RESPONSIBLE	APPROVED	ISSUED

ISSUES STAMP

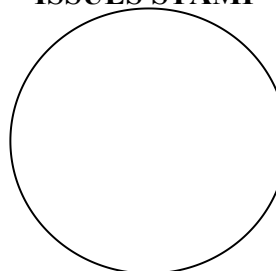

### Revised History

NO.	Revised Date	Description	Approved	Issued
1	2016-6-22	DOE6.0		2016-6-29

**GEO TECHNOLOGY CO., LTD.**

D.3 Building, Tianyang,4Road Tianyang Industrial,East AvenueSonggang Town , Shenzhen,Guangdong,Chi

<http://www.szjiao.com>

TEL:(86-755)33925289 FAX:(86-755)33925289

E-mail: made555888@163.com sjl@88gme.com

	<b>DESCRIPTION</b>	<b>SWITCHING POWER AC ADAPTER</b>	<b>SHEET NO.</b>	<b>1 OF 4</b>
	<b>MODEL NO.</b>	<b>GEO151UB-6025</b>	<b>VER:</b>	<b>A1</b>
			<b>PART NO.</b>	<b>C688-13917</b>

1.INPUT REQUIREMENT

2.OUTPUT SPECIFICATION

3.MECHANICAL

4.RELIABILITY

5.ENVIRONMENT

6.OUTLOOKING

7.SAFETY

8.QC CHECK

9.DIMENSION

10.LABEL

11.PACKING

	DESCRIPTION	SWITCHING POWER AC ADAPTER	SHEET NO.	2 OF 4
	MODEL NO.	GE0151UB-6025	VER:	A1
			PART NO.	C688-13917

### 1.INPUT REQUIREMENT

ITEM	SPECIFICATION	MIN	TYP.	MAX
NORMAL AC INPUT VOLTAGE	SINGLE PHASE	100Vac	110Vac/220Vac	240Vac
AC INPUT VOLTAGE RANGE	SINGLE PHASE	90Vac	110Vac/220Vac	264Vac
AC INPUT FREQUENCY	SINGLE PHASE	47Hz	50/60Hz	63Hz
AC INPUT CURRENT	TYPICAL INPUT VOLTAGE& OUTPUT AT FULL LOAD.			350mA
AC INRUSH CURRENT	TYPICAL INPUT VOLTAGE& OUTPUT AT FULL LOAD , 25°C.			30A
EFFICIENCY	TYPICAL INPUT VOLTAGE& OUTPUT AT FULL LOAD	80.27%		

### 2.OUTPUT SPECIFICATION

ITEM	SPECIFICATION	MIN	TYP.	MAX
NORMAL DC OUTPUT VOLTAGE			5.25V	
DC OUTPUT VOLTAGE RANGE	±5%	4.80V		5.60V
LOAD CURRENT RANGE			2.4A	
PEAK LOAD CURRENT	TIME<60S			
RIPPLE	TYPICAL INPUT VOLTAGE , TYPICAL LOAD CURRENT , 25°C			200mV
HOLD-UP TIME	AT TYPICAL INPUT VOLTAGE AND FULL LOAD	10mS		
TURN-ON DELAY	TYPICAL INPUT VOLTAGE AND TUP LOAD CURRENT			3S
OVER CURRENT PROTECTION	AUTO RECOVERY			
SHORT CIRCUIT PROTECTRON	THE ADAPTER SHALL NOT DAMAGE BY SHORT THE DC OUTPUT TO GROUND			
OVER VOLTAGE PROTECTION				0.1W

### \*TEST MEASURES

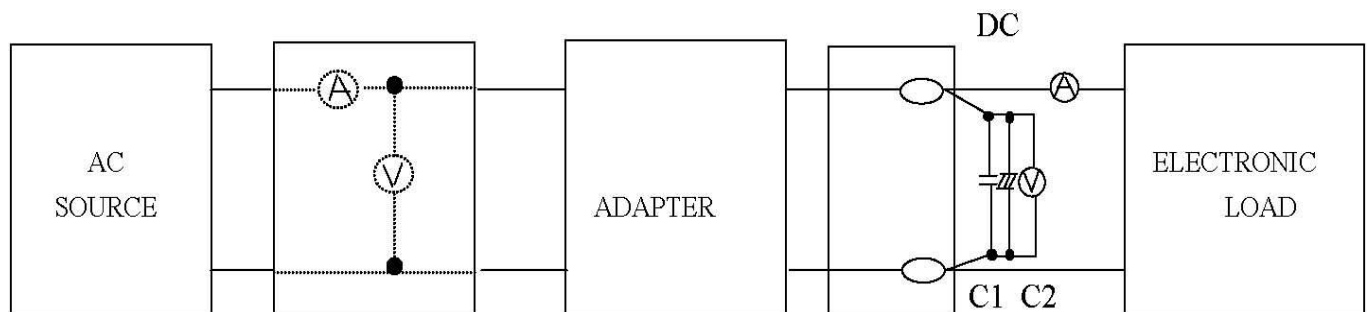

C1: 0.1uF CERAMICS CAPACITOR  
C2: 10uF 50V ALUMINUM CAPACITOR

	DESCRIPTION	SWITCHING POWER AC ADAPTER	SHEET NO.	3 OF 4
	MODEL NO.	GE0151UB-6025	VER:	A1
			PART NO.	C688-13917

### 3.MECHANICAL

ITEM	SPECIFICATION OR TEST CONDITION	ACCEPTANCE CRITERIA
BENDING TEST	NORMAL TEMPERATURE THE CORD SHALL WITHSTAND WEIGHT OF 200g, SWINGING FROM LEFT TO RIGHT AT AN ANGLE OF 60 DEG. 1000CYCLE TIMES MIN. S/R SHALL WITHSTAND WEIGHT OF 1N. SWINGING FROM LEFT TO RIGHT AT AN ANGLE OF 60DEG. 1000CYCLE TIMES MIN. BENDING SPEED 40CYCLE/MINUTE	NO SHORT CIRCUIT NO BREAKAGE OF THE CORD
VIBRATION	FREQUENCY RANGE:10~55Hz AMPLITUDE:1.5mm ACCELERATION: 1G SWEEP 1 MINUTE FOR X,Y,Z.AXIS EACH	THERE SHALL BENO ABNORMALITY ON THE APPEARNCE STRUCTURE AND OPERATING

### 4.RELIABILITY

ITEM	TEST CONDITION	ACCEPTANCE CRITERIA
TEMPERATURE UP WITH	TEST AT SURFACE OF THE CASE WITH TYPICAL	TEMPERATURE UP UNDER
TYPICAL LOAD	AC INPUT AND TYPICAL LOAD IN OUTPUT	35 DEGREES
	50/60Hz	
HI-POT TEST	INPUT TO OUTPUT GRADUALLY RAISED FROM 0 TO THE 3000Vac AND HELD AT THAT VALUE FOR 3S,10mA	NO DAMAGE
INSULATION RESISTANCE	INPUT TO OUTPUT,DC 500V	>10MΩ
MTBF	TYPICAL INPUT&FULL LOAD , 25℃	50000 HOURS
BURN-IN	AT 30℃(±10℃),NORMAL INPUT VOLTAGE	2~4 HOURS

### 5.ENVIRONMENT

ITEM	SPECIFICATION OR TEST CONDITION	min.	typ.	max.
OPERATING TEMPERATURE		0℃		40℃
STORAGE TEMPERATURE		-20℃		85℃
OPERATING HUMIDITY	NON-CONDENSING	5%RH		90%RH
STORAGE HUMIDITY	NON-CONDENSING	5%RH		90%RH

	DESCRIPTION	SWITCHING POWER AC ADAPTER	SHEET NO.	4 OF 4
			VER:	A1
	MODEL NO.	GE0151UB-6025	PART NO.	C688-13917

6.OUTLOOKING

DIMENSION :59.5(L)X25.7(W)X79(H)mm  
 WEIGHT :ABOUT g  
 AC INPUT TYPE : WALL MOUNT  
 DC OUTPUT TYPE :MICRO5PIN 类型

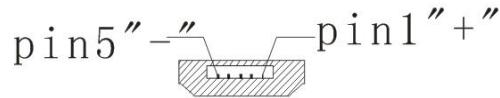

DC OUTPUT CABLE 2464 20AWG WIRE 线长1.8M  
 INDICATION :LABEL  
 CASE MATERIAL :94V-0 ABS+PC  
 PCB MATERIAL :94V-0

7.SAFETY

COMPLY SAFETY STANDARDS	STANDARD	FILE NO.
UL CE		

EMI
FCC

8.QC CHECK

ALL OF THE QUANTITY SHALL BE CHECKED BEFORE SHIPMENT,CHECK ITEM AS BELOW:  
 (1)DC PLUG POLE CHECK  
 (2)OCP FUNCTION CHECK  
 (3)DC OUTPUT VOLTAGE CHECK  
 (4)HIPOT&INSULATION CHECK  
 (5)OUTLOOKING CHECK

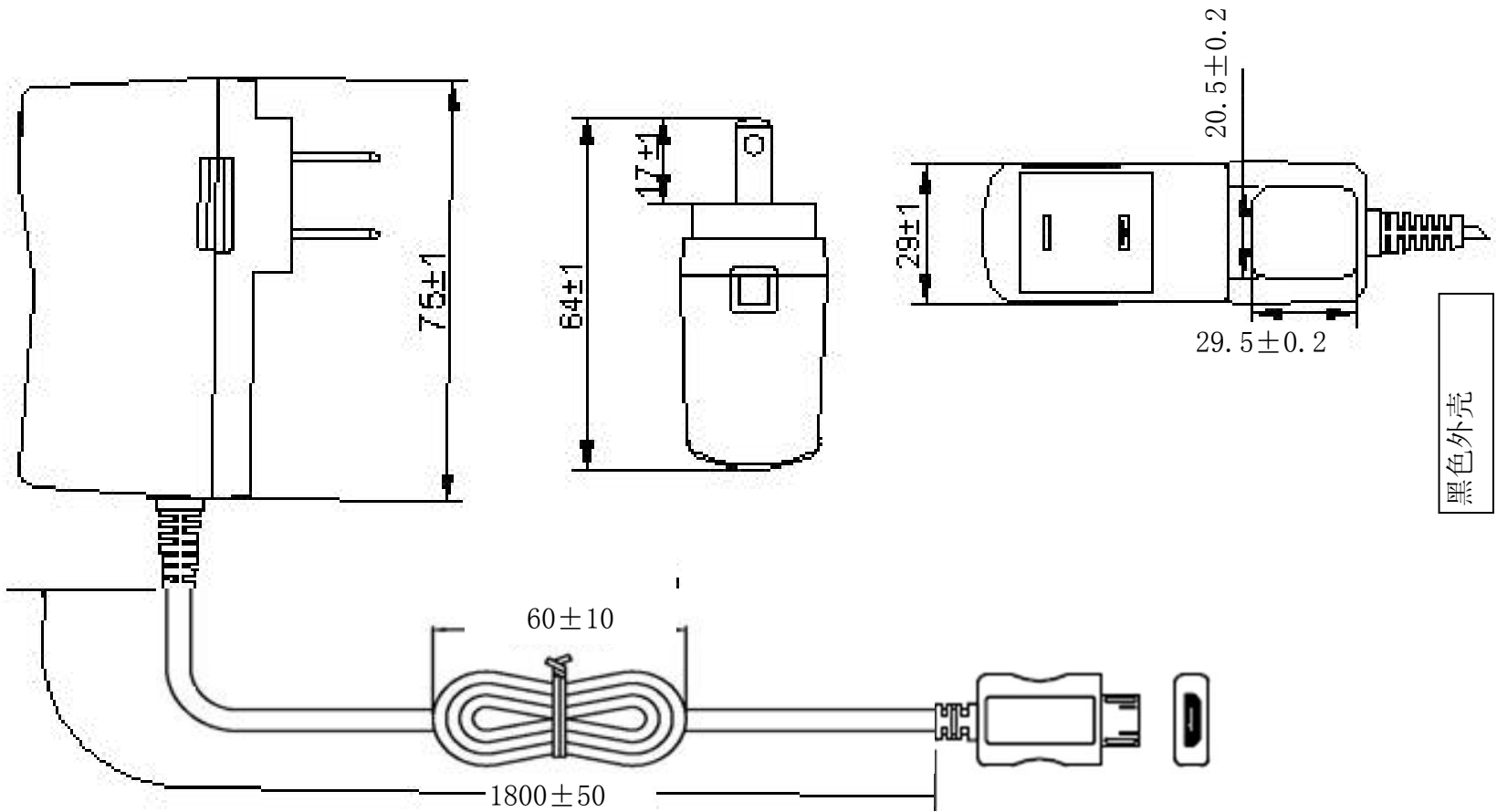

TOLERANCE				FINISH	XXXXXX		NAME	DIMENSION
0-4	4-10	10-30	30-100		MATERIAL	REV.		
$\pm 0.05$	$\pm 0.08$	$\pm 0.1$	$\pm 0.2$	XXX	A1			
$\pm 0.05$	$\pm 0.08$	$\pm 0.1$	$\pm 0.2$					
$\pm 0.1$	$\pm 0.15$	$\pm 0.25$	$\pm 0.4$					
$\pm 0.15$	$\pm 0.25$	$\pm 0.4$	$\pm 0.6$					
$\pm 0.2$	$\pm 0.4$	$\pm 0.6$	$\pm 1.0$					
DEC.	CHGD.	APPD.	UNIT	mm		PART NO.	C688-13917	
jmh			SCALE <td>REF.</td> <td>XXX</td>	REF.	XXX			
				DWG NO.	XXX			

20.5 ± 0.2

C2

29.5 ± 0.2

**SWITCHING AC/DC  
POWER ADAPTER**

---



MODEL:GEO151UB-6025  
 I/P:100-240V ~ 50/60Hz 0.35A  
 O/P:5.25V  $\equiv$  2.4A

I.T.E. POWER SUPPLY GMA102311-EA-001

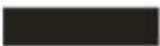

CE

  
 LISTED  
 E339441  
 3WH2

FC

MADE IN CHINA pin5"  pin1" +"

3-R1

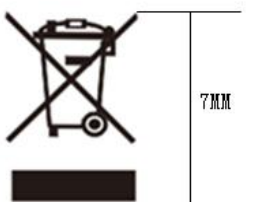

NOTE:  
 1.SILVER WORD ON BLACK BASE.  
 2.MATERIAL:PVC +MYLAR FILM.

TOLERANCE					FINISH	XXXXXX			NAME	LABEL
L < 4	4 < L ≤ 20	20 < L ≤ 50	50 < L ≤ 200	200 < L		MATERIAL	XXX	REV.		
DEG.	CHKD.	APPD.		UNIT	mm					
			SCALE	REF.	XXXX			PART NO.	C688-13917	
				DWG NO.	XXXX					

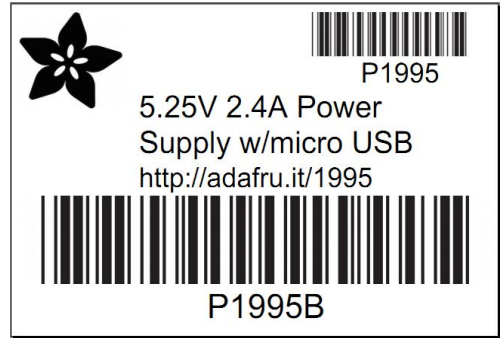
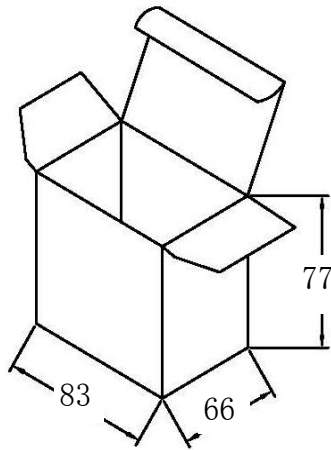

白盒标:  
尺寸: 57\*38mm,  
材质: 白底不干胶

WHITE INNER BOX+OUT CARTON

WHITE INNER BOX OUT SIDE DIMENSION:

L×W×H(83\*66\*77 )

TOLERANCE:±3

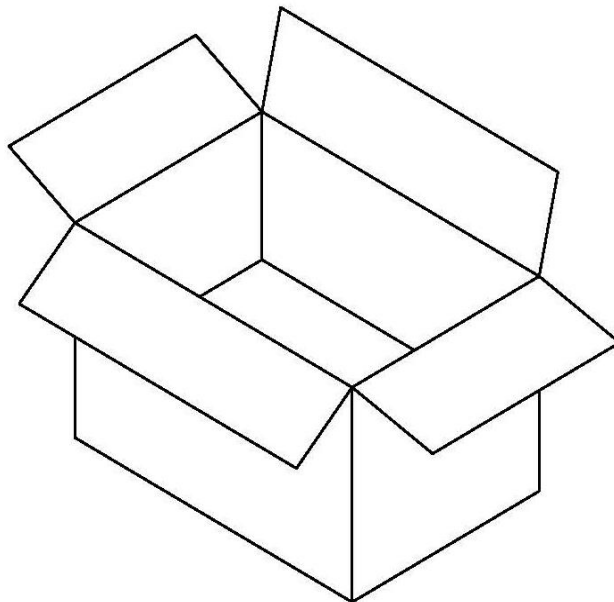

490\*350\*265 外销箱

TOLERANCE					FINISH				NAME	PACKING
L<4	4<L<20	20<L<50	50<L<200	200<L			REV.	A1		
±0.05	±0.08	±0.1	±0.2	±0.3	MATERIAL					
±0.08	±0.1	±0.2	±0.3	±0.4						
±0.1	±0.15	±0.3	±0.4	±0.6						
±0.15	±0.25	±0.4	±0.6	±0.8						
DEG.	CHKD.	APPD.			UNIT	mm			PART NO.	C688-13917
			SCALE		REF.					
					DWG NO.					