



Chipsmall Limited consists of a professional team with an average of over 10 year of expertise in the distribution of electronic components. Based in Hongkong, we have already established firm and mutual-benefit business relationships with customers from,Europe,America and south Asia,supplying obsolete and hard-to-find components to meet their specific needs.

With the principle of “Quality Parts,Customers Priority,Honest Operation,and Considerate Service”,our business mainly focus on the distribution of electronic components. Line cards we deal with include Microchip,ALPS,ROHM,Xilinx,Pulse,ON,Everlight and Freescale. Main products comprise IC,Modules,Potentiometer,IC Socket,Relay,Connector.Our parts cover such applications as commercial,industrial, and automotives areas.

We are looking forward to setting up business relationship with you and hope to provide you with the best service and solution. Let us make a better world for our industry!



Contact us

Tel: +86-755-8981 8866 Fax: +86-755-8427 6832

Email & Skype: info@chipsmall.com Web: www.chipsmall.com

Address: A1208, Overseas Decoration Building, #122 Zhenhua RD., Futian, Shenzhen, China



REVISONS		DATE	DN	APVD
F	REV PER ECO 09-025422	11-16-09	CT	KT

- CONNECTOR DIMENSIONS ARE PER ARINC 600 SPECIFICATION UNLESS OTHERWISE SPECIFIED.
- CONNECTOR IS SUPPLIED WITH CONTACTS (PER TABLE) ASSEMBLED AS SHOWN.
- KEYING SHOWN IN POSITION FOR ILLUSTRATION ONLY. CONNECTORS SHIPPED WITH KEYING INSTALLED IN POSITION PER TABLE.
- DUST COVER INSTALLED FOR SHIPPING, NOT SHOWN.
- WITH CONTACT FULLY SEATED IN CAVITY.
- THIS DIMENSION IS MEASURED TO THE BACK OF THE SHELL NOT THE HIRF.

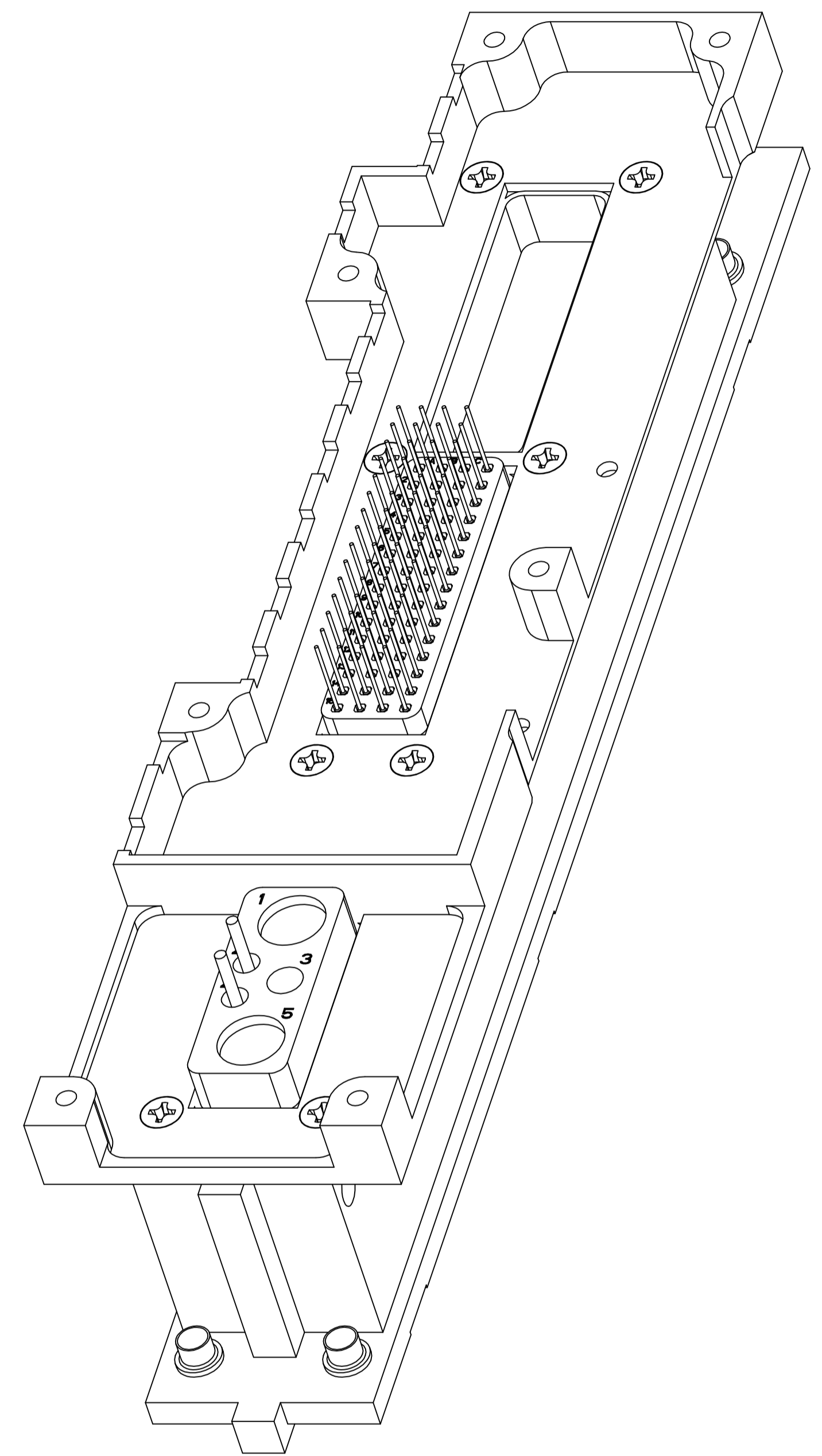
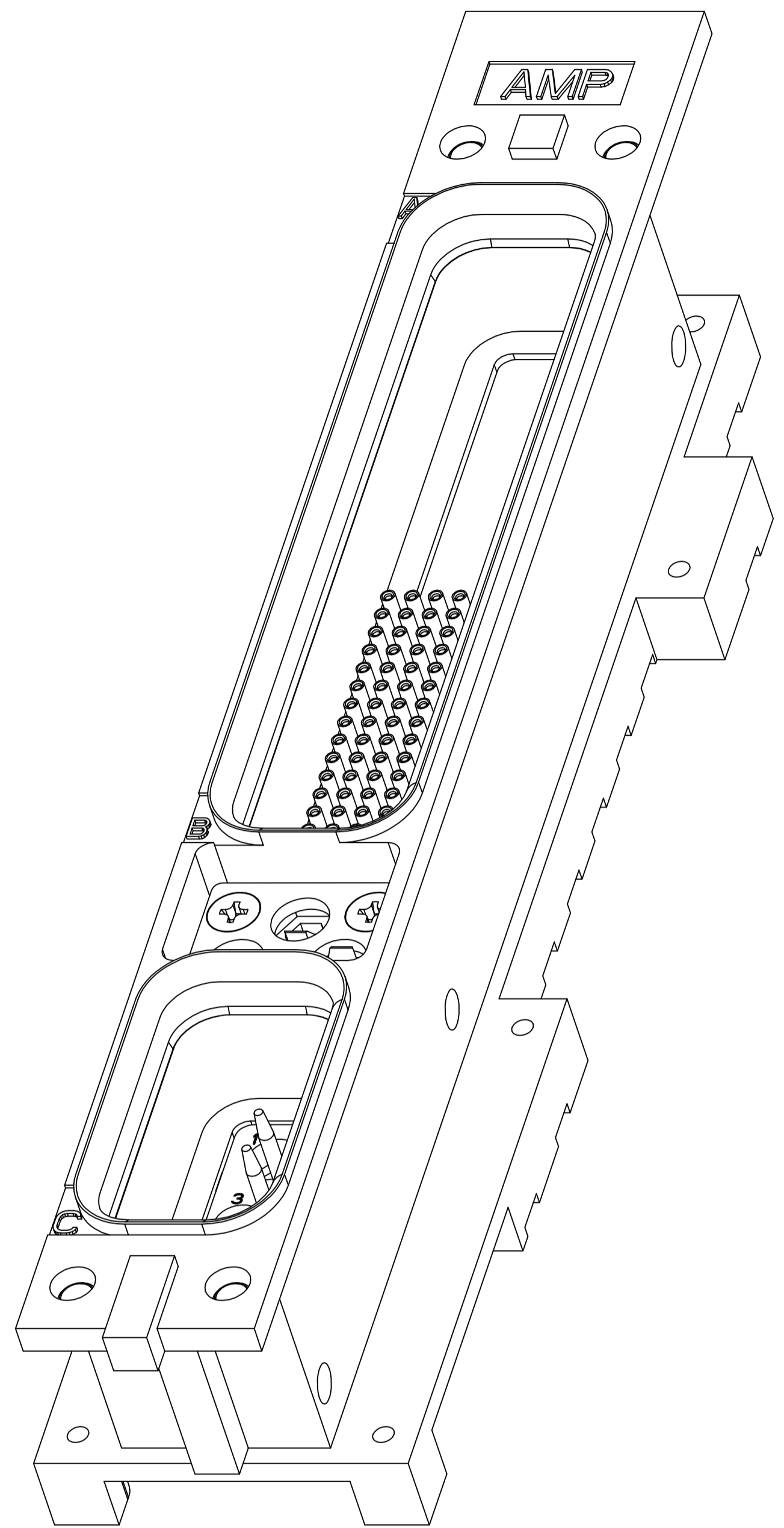

COMPONENT	MATERIAL	FINISH
SHELL	DIE CAST ALUMINUM PER ASTM-B-85	ELECTROLESS NICKEL PER MIL-C-26074
HIRF HOUSING RETENTION PLATE	ALUMINUM ALLOY 6061-T6	ELECTROLESS NI QQ-N-290 .0006 MIN OVER CU .0002
SCREWS AND LOCK WASHERS	STEEL	ZINC PLATED OVER SUPPLEMENTAL CHROMATE
POLARIZING KEYS	ZINC ALLOY PER ASTM-B-86	-
POLARIZING KEY RETAINING PLATE	ALUMINUM ALLOY PER ASTM-B-209	BLUE ANODIZED PER MIL-A-8625
60 & 5C2 INSERTS	THERMOSET	-
BLANK INSERT	ALUMINUM ALLOY PER ASTM-B-209	ELECTROLESS NICKEL PER MIL-C-26074
FILLER PLUG	TEFLON	-

"04"	HIRF P/N: 1996859-1; HONEYWELL P/N: 047-50511-0501 MODULE A: BLANK MODULE B: SZ 22 POSTED PIN CONTACT: TE P/N 1-211431-8 (QTY=60) MODULE C: SZ 16 POSTED PIN CONTACT: TE P/N 3-448139-3 (QTY=2) LOADED IN POSITION #2 & 4 SZ 12 SEALING PLUG: TE P/N 1663767-4 (QTY=1) LOADED IN POSITION #3 SZ 5 SEALING PLUG: TE P/N 205975-1 (QTY=1) LOADED IN POSITION #5	1996502-1
	KEYING POSITION	CONTACTS & SEALING PLUGS INCLUDED AND INSTALLED

THIS DRAWING IS A CONTROLLED DOCUMENT.

DIMENSIONS: INCHES (mm)	TOLERANCES UNLESS OTHERWISE SPECIFIED:	0 PLC ± -	1 PLC ± -	2 PLC ± -	3 PLC ± .005 (0.13)	4 PLC ± -	ANGLES ± -
-------------------------	--	-----------	-----------	-----------	---------------------	-----------	------------

MATERIAL: SEE TABLE FINISH: SEE TABLE

APPROVED: K. THACKSTON DATE: 10-9-08

DESIGNED: C.C. THOMAS DATE: 10-9-08

DRW: K. THACKSTON DATE: 10-9-08

NAME: Tyco Electronics Corporation, Harrisburg, PA 17105-3608

PRODUCT SPEC: RECEPTACLE ASSY, SIZE 1, ARINC 600 (BLANK/60/5C2)

APPLICATION SPEC: -

SIZE: A1 CAGE CODE: 00779 DRAWING NO: 1996502

RESTRICTED TO: -

WEIGHT: - SCALE: 3:2 SHEET: 1 OF 2 REV: F

CUSTOMER DRAWING

LOC		DIST		REVISIONS			
P	LTR	DESCRIPTION	DATE	DWN	APVD		
-	-	SEE SHEET #1	-	-	-	-	-

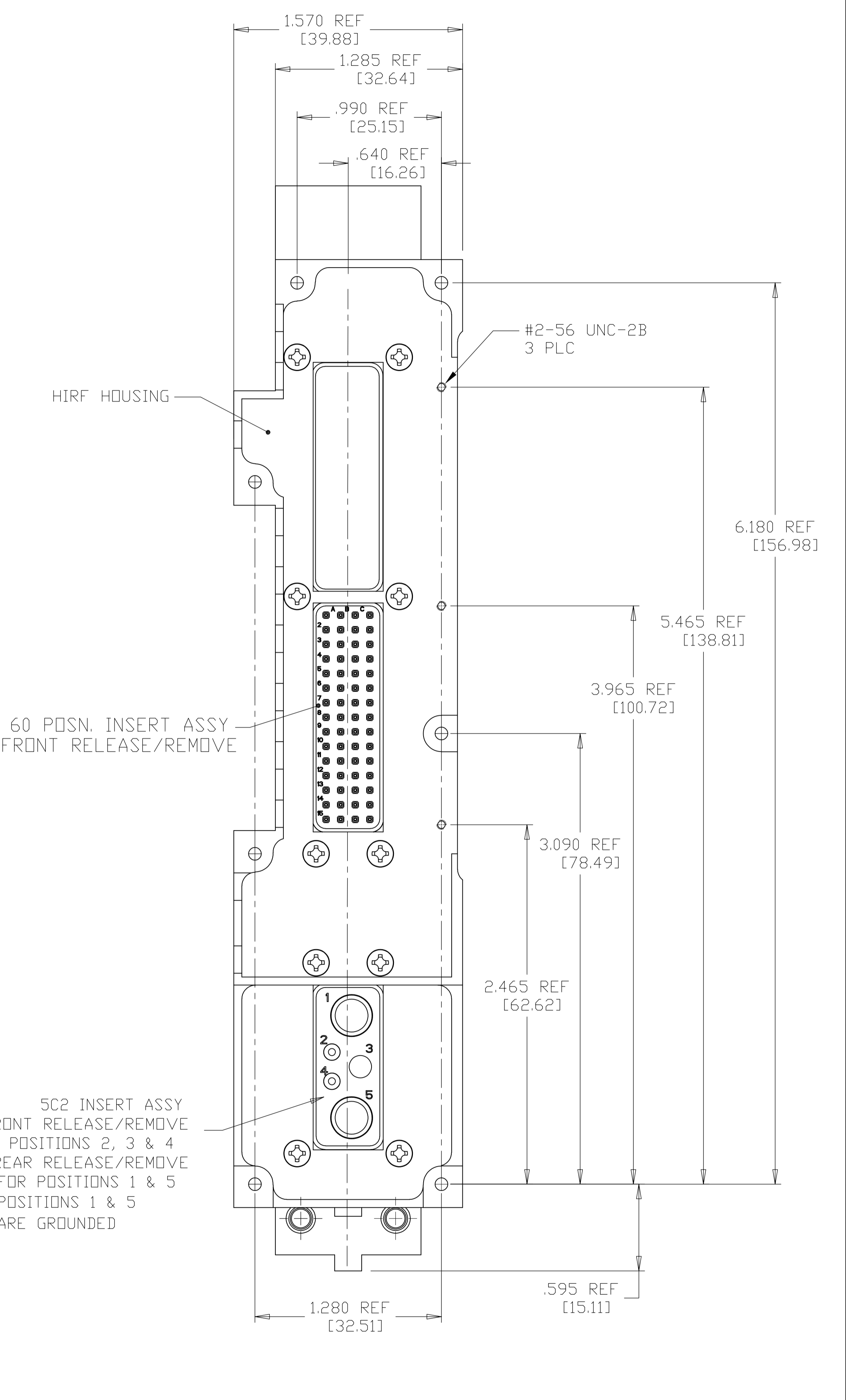
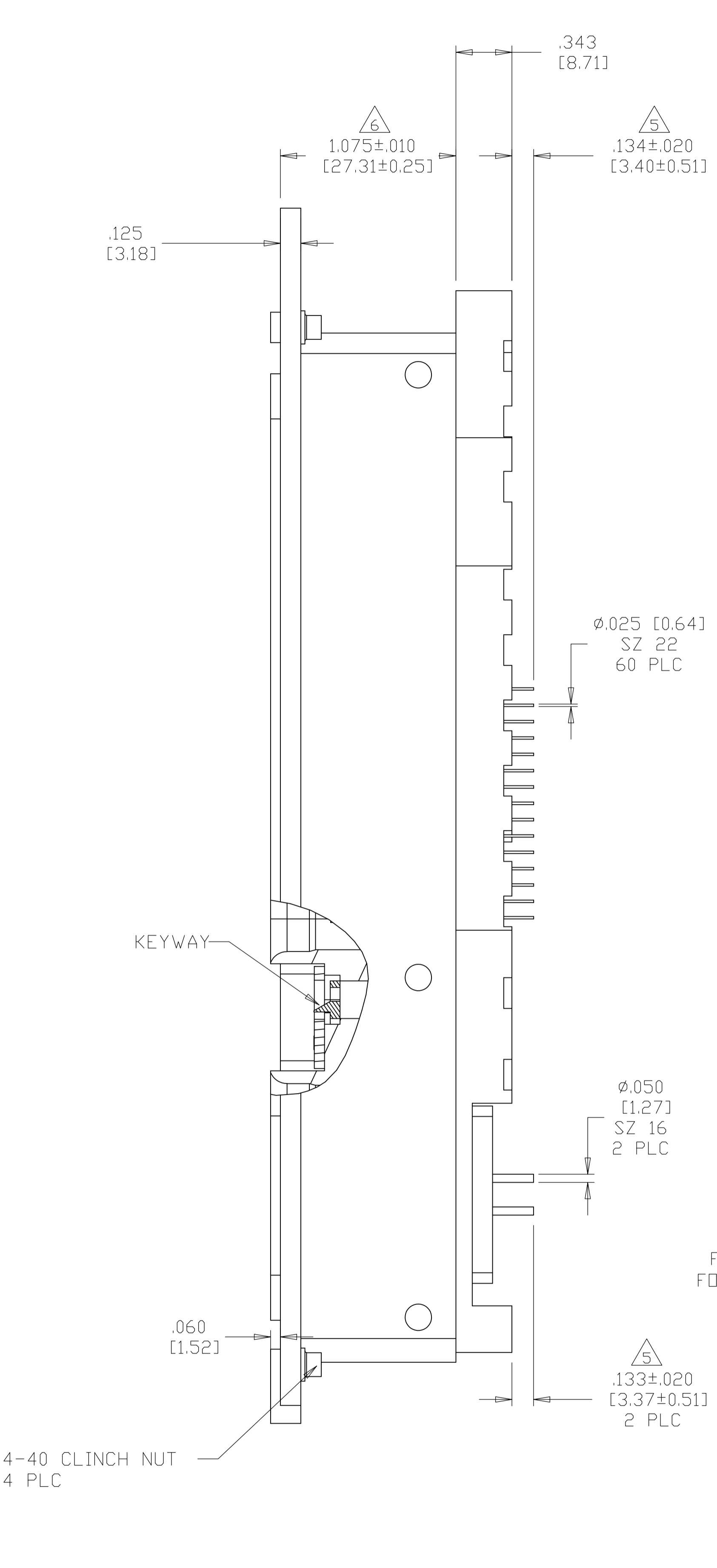
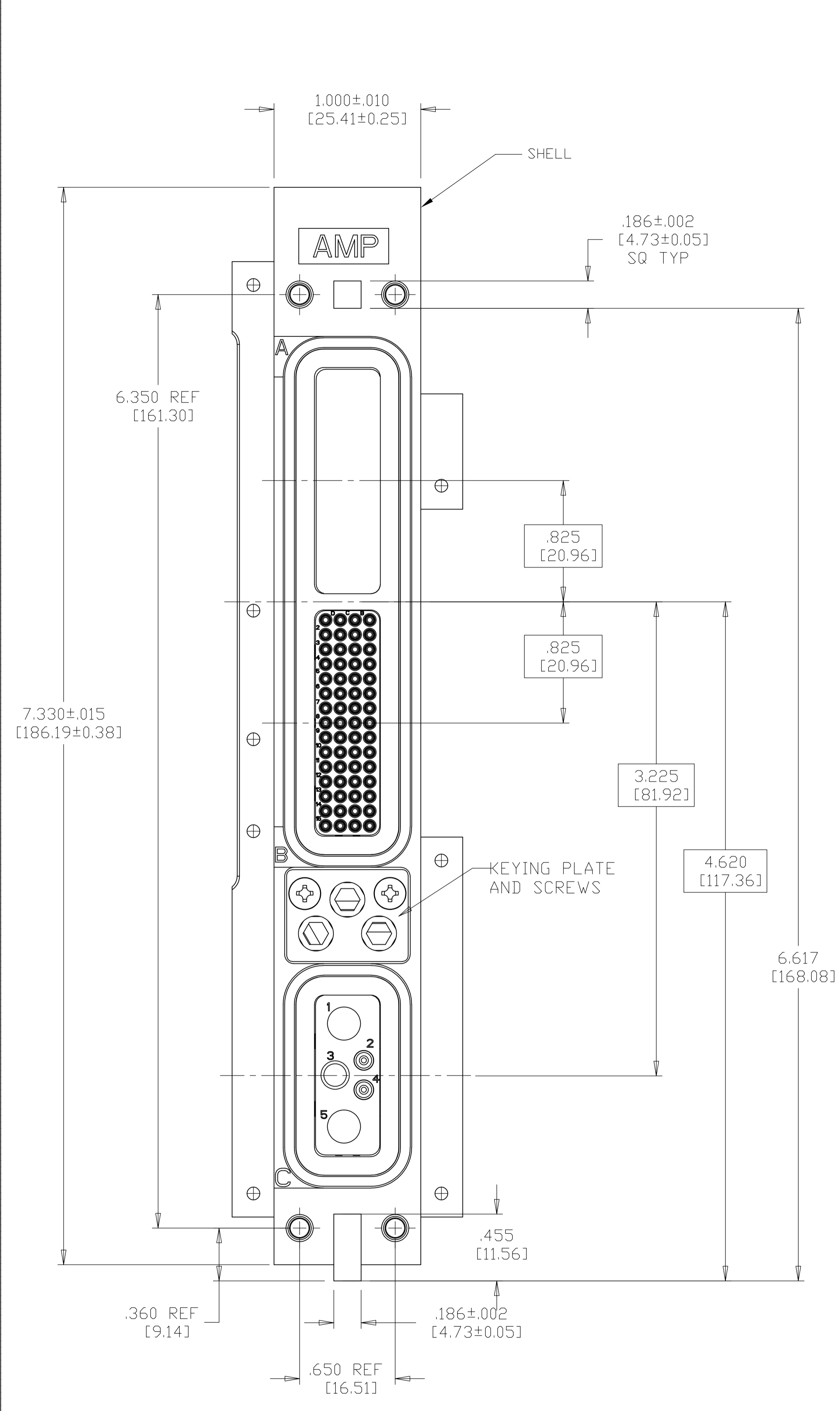

THIS DRAWING IS A CONTROLLED DOCUMENT.		DIN C.C.THOMAS 10-9-08	Tyco Electronics Corporation Harrisburg, PA 17105-3608	
DIMENSIONS: INCHES [mm]		CHK K.THACKSTON 10-9-08	NAME K.THACKSTON	
TOLERANCES UNLESS OTHERWISE SPECIFIED:		PRODUCT SPEC		
0 PLC ± -	1 PLC ± -	APPLICATION SPEC		
2 PLC ± -	3 PLC ± .005 [0.13]	SIZE A1		
4 PLC ± -	ANGLES ± -	CAGE CODE 00779		
MATERIAL SEE TABLE		FINISH SEE TABLE		DRAWING NO. 1996502
WEIGHT		RESTRICTED TO		SCALE 3:2
CUSTOMER DRAWING		SHEET 2 OF 2		REV F