



Chipsmall Limited consists of a professional team with an average of over 10 year of expertise in the distribution of electronic components. Based in Hongkong, we have already established firm and mutual-benefit business relationships with customers from,Europe,America and south Asia,supplying obsolete and hard-to-find components to meet their specific needs.

With the principle of “Quality Parts,Customers Priority,Honest Operation,and Considerate Service”,our business mainly focus on the distribution of electronic components. Line cards we deal with include Microchip,ALPS,ROHM,Xilinx,Pulse,ON,Everlight and Freescale. Main products comprise IC,Modules,Potentiometer,IC Socket,Relay,Connector.Our parts cover such applications as commercial,industrial, and automotives areas.

We are looking forward to setting up business relationship with you and hope to provide you with the best service and solution. Let us make a better world for our industry!



Contact us

Tel: +86-755-8981 8866 Fax: +86-755-8427 6832

Email & Skype: info@chipsmall.com Web: www.chipsmall.com

Address: A1208, Overseas Decoration Building, #122 Zhenhua RD., Futian, Shenzhen, China



1EDI EiceDRIVER™ Compact

Separate output variant for IGBT

Single Channel IGBT Gate Driver IC

1EDI05I12AF
1EDI20I12AF
1EDI40I12AF
1EDI60I12AF

Data Sheet

Rev. 2.0, 2014-11-10

Edition 2014-11-10

**Published by
Infineon Technologies AG
81726 Munich, Germany**

**© 2014 Infineon Technologies AG
All Rights Reserved.**

Legal Disclaimer

The information given in this document shall in no event be regarded as a guarantee of conditions or characteristics. With respect to any examples or hints given herein, any typical values stated herein and/or any information regarding the application of the device, Infineon Technologies hereby disclaims any and all warranties and liabilities of any kind, including without limitation, warranties of non-infringement of intellectual property rights of any third party.

Information

For further information on technology, delivery terms and conditions and prices, please contact the nearest Infineon Technologies Office (www.infineon.com).

Warnings

Due to technical requirements, components may contain dangerous substances. For information on the types in question, please contact the nearest Infineon Technologies Office.

Infineon Technologies components may be used in life-support devices or systems only with the express written approval of Infineon Technologies, if a failure of such components can reasonably be expected to cause the failure of that life-support device or system or to affect the safety or effectiveness of that device or system. Life support devices or systems are intended to be implanted in the human body or to support and/or maintain and sustain and/or protect human life. If they fail, it is reasonable to assume that the health of the user or other persons may be endangered.

Revision History

Page or Item	Subjects (major changes since previous revision)
Rev. 2.0, 2014-11-10	
all pages	Final DS, completion of parameters and editorial changes
Rev. 1.01, 2014-10-14	
all pages	completion of parameters

Trademarks of Infineon Technologies AG

AURIX™, BlueMoon™, C166™, CanPAK™, CIPOS™, CIPURSE™, COMNEON™, EconoPACK™, CoolMOS™, CoolSET™, CORECONTROL™, CROSSAVE™, DAVE™, EasyPIM™, EconoBRIDGE™, EconoDUAL™, EconoPIM™, EiceDRIVER™, eupec™, FCOS™, HITFET™, HybridPACK™, I²RF™, ISOFACE™, IsoPACK™, MIPAQ™, ModSTACK™, my-d™, NovalithIC™, OmniTune™, OptiMOS™, ORIGA™, PRIMARION™, PrimePACK™, PrimeSTACK™, PRO-SIL™, PROFET™, RASIC™, ReverSave™, SatRIC™, SIEGET™, SINDRION™, SIPMOS™, SMARTi™, SmartLEWIS™, SOLID FLASH™, TEMPFET™, thinQ!™, TRENCHSTOP™, TriCore™, X-GOLD™, X-PMU™, XMM™, XPOSYS™.

Other Trademarks

Advance Design System™ (ADS) of Agilent Technologies, AMBA™, ARM™, MULTI-ICE™, KEIL™, PRIMECELL™, REALVIEW™, THUMB™, μVision™ of ARM Limited, UK. AUTOSAR™ is licensed by AUTOSAR development partnership. Bluetooth™ of Bluetooth SIG Inc. CAT-ig™ of DECT Forum. COLOSSUS™, FirstGPS™ of Trimble Navigation Ltd. EMV™ of EMVCo, LLC (Visa Holdings Inc.). EPCOS™ of Epcos AG. FLEXGO™ of Microsoft Corporation. FlexRay™ is licensed by FlexRay Consortium. HYPERTERMINAL™ of Hilgraeve Incorporated. IEC™ of Commission Electrotechnique Internationale. IrDA™ of Infrared Data Association Corporation. ISO™ of INTERNATIONAL ORGANIZATION FOR STANDARDIZATION. MATLAB™ of MathWorks, Inc. MAXIM™ of Maxim Integrated Products, Inc. MICROTEC™, NUCLEUS™ of Mentor Graphics Corporation. Mifare™ of NXP. MIPI™ of MIPI Alliance, Inc. MIPS™ of MIPS Technologies, Inc., USA. muRata™ of MURATA MANUFACTURING CO., MICROWAVE OFFICE™ (MWO) of Applied Wave Research Inc., OmniVision™ of OmniVision Technologies, Inc. Openwave™ Openwave Systems Inc. RED HAT™ Red Hat, Inc. RFMD™ RF Micro Devices, Inc. SIRIUS™ of Sirius Satellite Radio Inc. SOLARIS™ of Sun Microsystems, Inc. SPANSION™ of Spansion LLC Ltd. Symbian™ of Symbian Software Limited. TAIYO YUDEN™ of Taiyo Yuden Co. TEAKLITE™ of CEVA, Inc. TEKTRONIX™ of Tektronix Inc. TOKO™ of TOKO KABUSHIKI KAISHA TA. UNIX™ of X/Open Company Limited. VERILOG™, PALLADIUM™ of Cadence Design Systems, Inc. VLYNQ™ of Texas Instruments Incorporated. VXWORKS™, WIND RIVER™ of WIND RIVER SYSTEMS, INC. ZETEX™ of Diodes Zetex Limited.

Last Trademarks Update 2010-10-26

Table of Contents

	Table of Contents	4
	List of Figures	5
	List of Tables	6
1	Overview	7
2	Block Diagram	9
3	Pin Configuration and Functionality	10
3.1	Pin Configuration	10
3.2	Pin Functionality	10
4	Functional Description	12
4.1	Introduction	12
4.2	Supply	12
4.3	Protection Features	13
4.3.1	Undervoltage Lockout (UVLO)	13
4.3.2	Active Shut-Down	13
4.3.3	Short Circuit Clamping	13
4.4	Non-Inverting and Inverting Inputs	13
4.5	Driver Outputs	13
5	Electrical Parameters	14
5.1	Absolute Maximum Ratings	14
5.2	Operating Parameters	15
5.3	Electrical Characteristics	15
5.3.1	Voltage Supply	15
5.3.2	Logic Input	16
5.3.3	Gate Driver	16
5.3.4	Short Circuit Clamping	17
5.3.5	Dynamic Characteristics	17
5.3.6	Active Shut Down	18
6	Timing Diagrams	19
7	Package Outlines	20
8	Application Notes	21
8.1	Reference Layout for Thermal Data	21
8.2	Printed Circuit Board Guidelines	21

List of Figures

Figure 1	Typical Application	8
Figure 2	Block Diagram 1EDI05I12AF, 1EDI20I12AF, 1EDI40I12AF and 1EDI60I12AF	9
Figure 3	PG-DSO-8-51 (top view).	10
Figure 4	Application Example Bipolar Supply	12
Figure 5	Application Example Unipolar Supply	12
Figure 6	Propagation Delay, Rise and Fall Time	19
Figure 7	Typical Switching Behavior.	19
Figure 8	UVLO Behavior.	19
Figure 9	PG-DSO-8-51 (Plastic (Green) Dual Small Outline Package)	20
Figure 10	Reference Layout for Thermal Data (JEDEC 1s0p, 100mm ² , Copper thickness 35 μm)	21

List of Tables

Table 1	Pin Configuration	10
Table 2	Absolute Maximum Ratings	14
Table 3	Operating Parameters	15
Table 4	Voltage Supply	15
Table 5	Logic Input	16
Table 6	Gate Driver	16
Table 7	Short Circuit Clamping	17
Table 8	Dynamic Characteristics	17
Table 9	Active Shut Down	18

1EDI EiceDRIVER™ Compact Single Channel IGBT Gate Driver IC

Separate output
variant for IGBT

1 Overview

Main Features

- Single channel isolated IGBT Driver
- Input to output isolation voltage up to 1200 V
- For high voltage power IGBTs
- Up to 10 A typical peak current at rail-to-rail outputs
- Separate source and sink outputs

Product Highlights

- Galvanically isolated Coreless Transformer Driver
- Wide input voltage operating range
- Suitable for operation at high ambient temperature

Typical Application

- AC and Brushless DC Motor Drives
- High Voltage DC/DC-Converter and DC/AC-Inverter
- Induction Heating Resonant Application
- UPS-Systems
- Welding
- Solar

Description

The 1EDI05I12AF, 1EDI20I12AF, 1EDI40I12AF, and 1EDI60I12AF are galvanically isolated single channel IGBT driver in a PG-DSO-8-51 package that provide minimum output currents up to 6 A at separated output pins.

The input logic pins operate on a wide input voltage range from 3 V to 15 V using CMOS threshold levels to support even 3.3 V microcontroller.

Data transfer across the isolation barrier is realized by the Coreless Transformer Technology.

Every driver family member comes with logic input and driver output under voltage lockout (UVLO) and active shutdown.



Product Name	Gate Drive Current (min)	Package
1EDI05I12AF	±0.5 A	PG-DSO-8-51
1EDI20I12AF	±2.0 A	PG-DSO-8-51
1EDI40I12AF	±4.0 A	PG-DSO-8-51
1EDI60I12AF	±6.0 A	PG-DSO-8-51

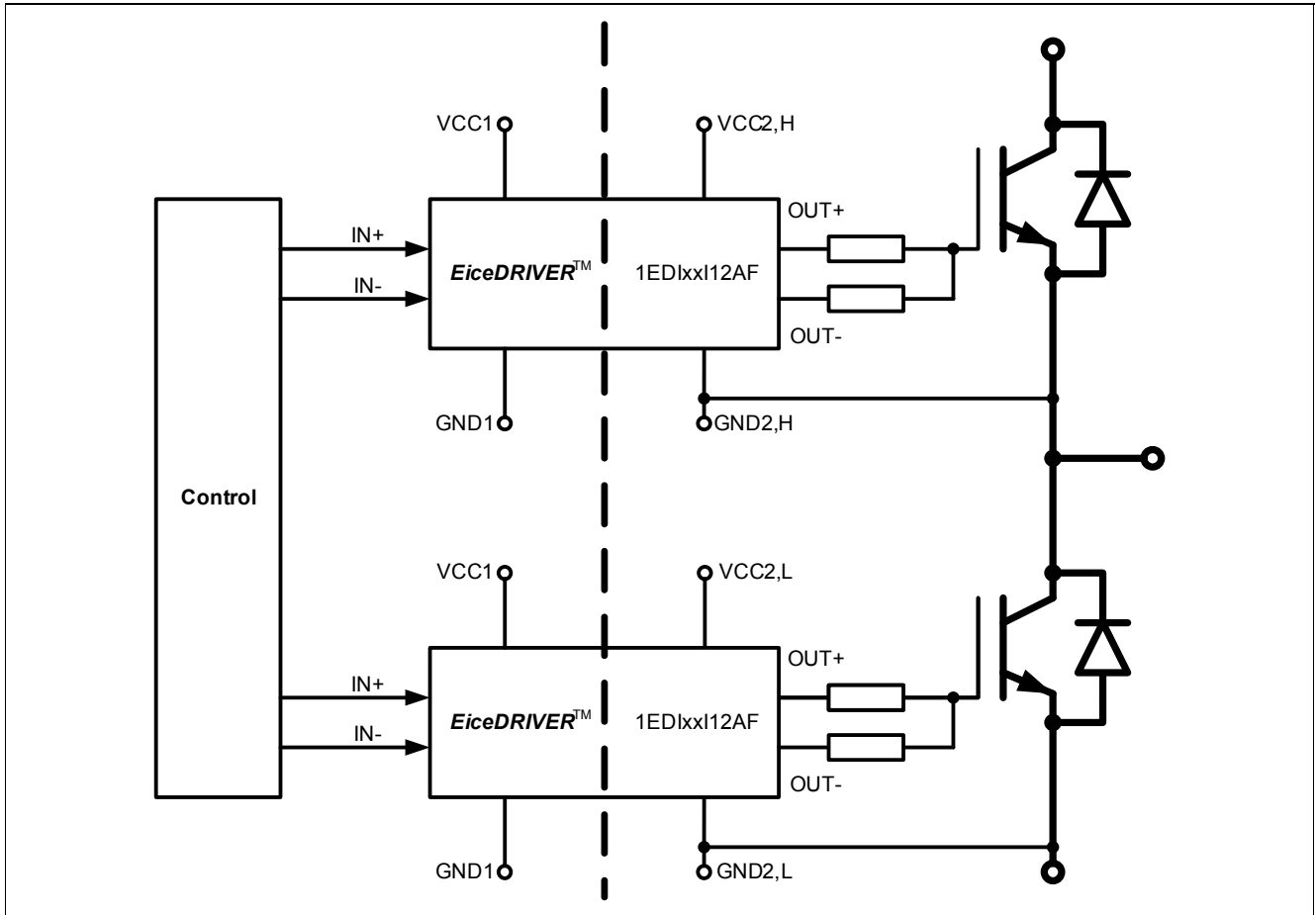

Figure 1 Typical Application

2 Block Diagram

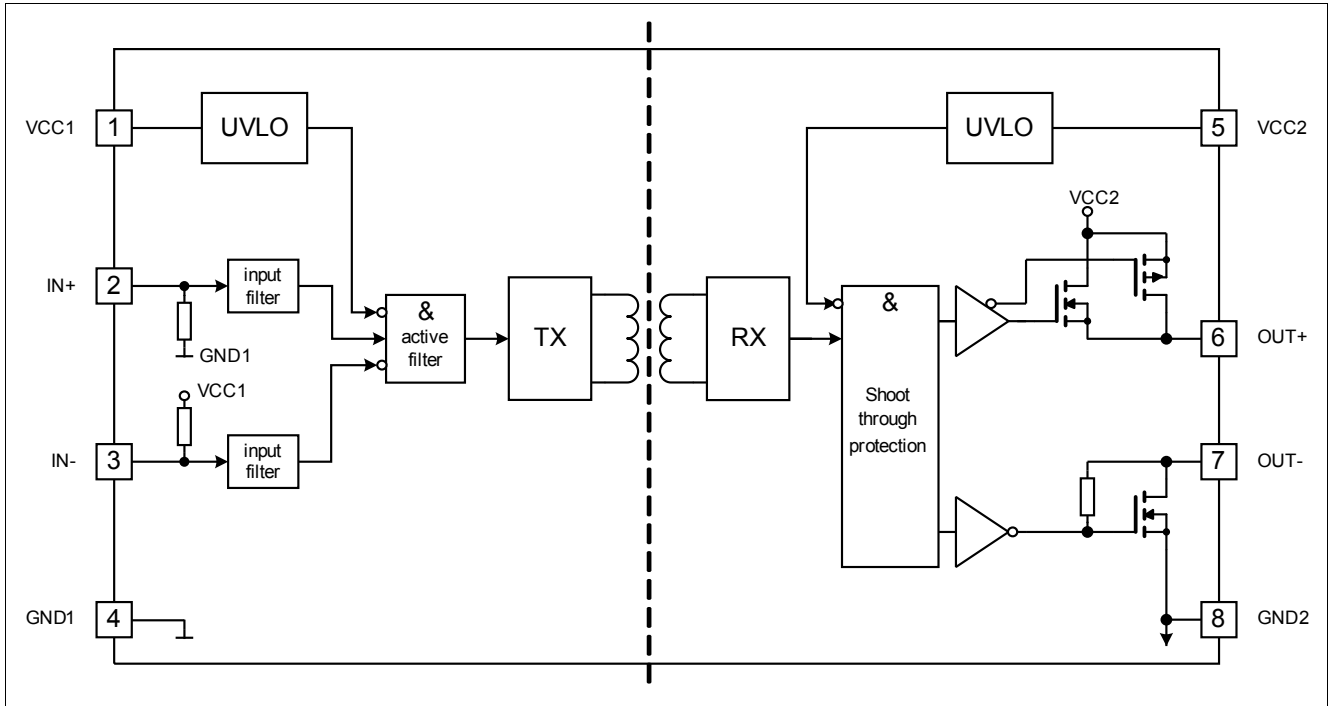

Figure 2 Block Diagram 1EDI05I12AF, 1EDI20I12AF, 1EDI40I12AF and 1EDI60I12AF

3 Pin Configuration and Functionality

3.1 Pin Configuration

Table 1 Pin Configuration

Pin No.	Name	Function
1	VCC1	Positive Logic Supply
2	IN+	Non-Inverted Driver Input (active high)
3	IN-	Inverted Driver Input (active low)
4	GND1	Logic Ground
5	VCC2	Positive Power Supply Output Side
6	OUT+	Driver Source Output
7	OUT-	Driver Sink Output
8	GND2	Power Ground

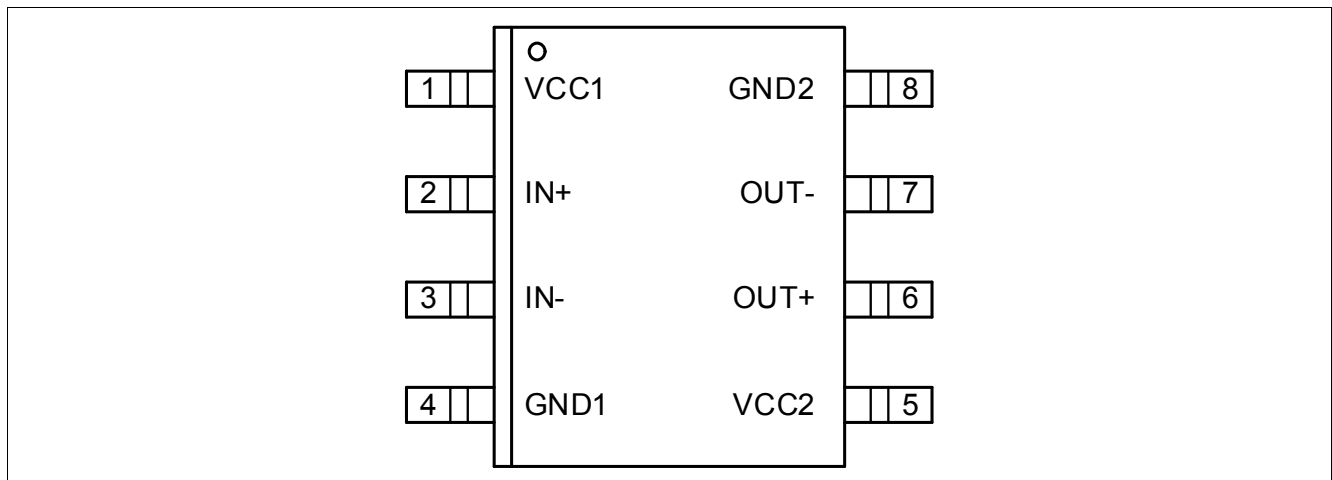

Figure 3 PG-DSO-8-51 (top view)

3.2 Pin Functionality

VCC1

Logic Input supply voltage of 3.3 V up to 15 V wide operating range.

IN+ Non Inverting Driver Input

IN+ non-inverted control signal for driver output if IN- is set to low. (Output sourcing active at IN+ = high and IN- = low)

Due to internal filtering a minimum pulse width is defined to ensure robustness against noise at IN+. An internal weak pull-down-resistor favors off-state.

IN- Inverting Driver Input

IN- inverted control signal for driver output if IN+ is set to high. (Output sourcing active at IN- = low and IN+ = high)
Due to internal filtering a minimum pulse width is defined to ensure robustness against noise at IN-. An internal weak pull-up-resistor favors off-state.

GND1

Ground connection of input circuit.

VCC2

Positive power supply pin of output driving circuit. A proper blocking capacitor has to be placed close to this supply pin.

OUT+ Driver Source Output

Driver source output pin to turn on external IGBT. During on-state the driving output is switched to VCC2. Switching of this output is controlled by IN+ and IN-. This output will also be turned off at an UVLO event.

During turn off the OUT+ terminal is able to sink approx. 100 mA.

OUT- Driver Sink Output

Driver sink output pin to turn off external IGBT. During off-state the driving output is switched to GND2. Switching of this output is controlled by IN+ and IN-. In case of UVLO an active shut down keeps the output voltage at a low level.

GND2 Reference Ground

Reference ground of the output driving circuit.

In case of a bipolar supply (positive and negative voltage referred to IGBT emitter) this pin is connected to the negative supply voltage.

4 Functional Description

4.1 Introduction

The 1EDI EiceDRIVER™ Compact is a general purpose IGBT gate driver. Basic control and protection features support fast and easy design of highly reliable systems.

The integrated galvanic isolation between control input logic and driving output stage grants additional safety. Its wide input voltage supply range support the direct connection of various signal sources like DSPs and microcontrollers.

The separated rail-to-rail driver outputs simplify gate resistor selection, save an external high current bypass diode and enhance dV/dt control.

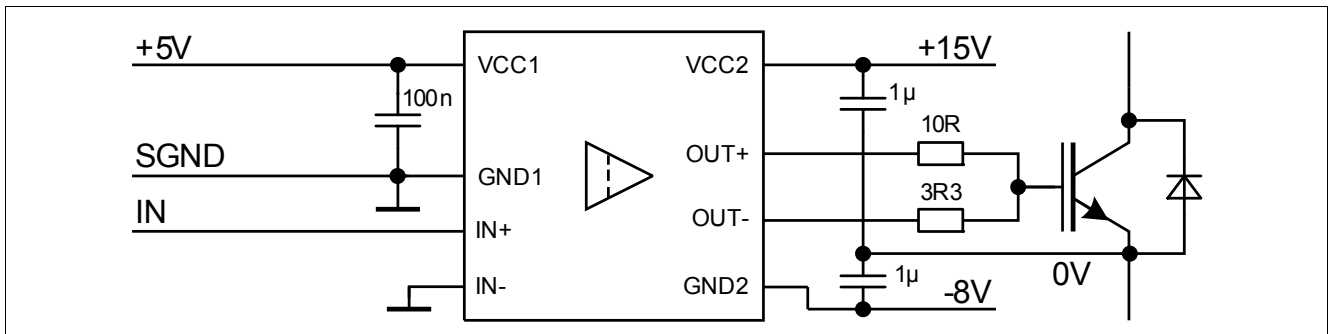

Figure 4 Application Example Bipolar Supply

4.2 Supply

The driver can operate over a wide supply voltage range, either unipolar or bipolar.

With bipolar supply the driver is typically operated with a positive voltage of 15 V at VCC2 and a negative voltage of -8V at GND2 relative to the emitter of the IGBT as seen in [Figure 4](#). Negative supply can help to prevent a dynamic turn on due to the additional charge which is generated from IGBT's input capacitance.

For unipolar supply configuration the driver is typically supplied with a positive voltage of 15 V at VCC2. In this case, careful evaluation for turn off gate resistor selection is recommended to avoid dynamic turn on (see [Figure 5](#)).

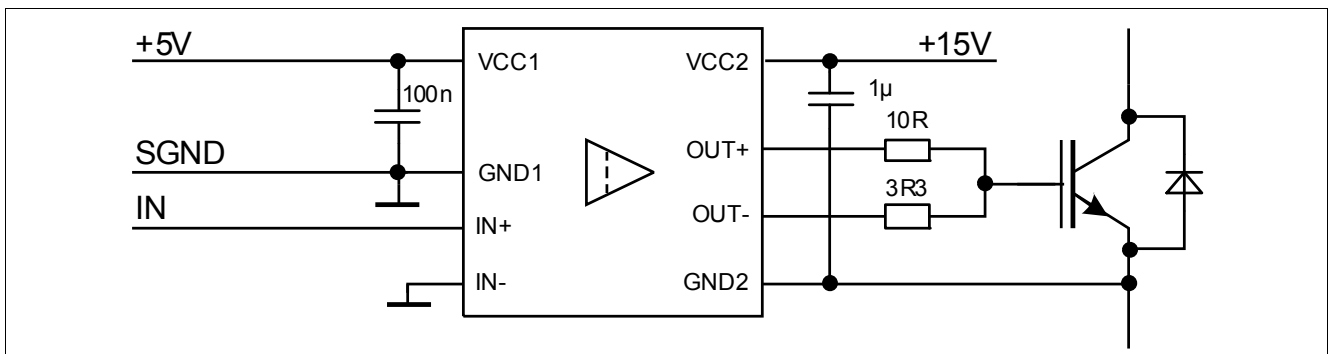

Figure 5 Application Example Unipolar Supply

4.3 Protection Features

4.3.1 Undervoltage Lockout (UVLO)

To ensure correct switching of IGBTs the device is equipped with an undervoltage lockout for input and output independently. Operation starts only after both VCC levels have increased beyond the respective V_{UVLOH} levels (see also [Figure 8](#)).

If the power supply voltage V_{VCC1} of the input chip drops below V_{UVLOL1} a turn-off signal is sent to the output chip before power-down. The IGBT is switched off and the signals at IN+ and IN- are ignored until V_{VCC1} reaches the power-up voltage V_{UVLOH1} again.

If the power supply voltage V_{VCC2} of the output chip goes down below V_{UVLOL2} the IGBT is switched off and signals from the input chip are ignored until V_{VCC2} reaches the power-up voltage V_{UVLOH2} again.

Note: V_{VCC2} is always referred to GND2 and does not differentiate between unipolar or bipolar supply.

4.3.2 Active Shut-Down

The Active Shut-Down feature ensures a safe IGBT off-state in case the output chip is not connected to the power supply or an under voltage lockout is in effect. The IGBT gate is clamped at OUT- to GND2.

4.3.3 Short Circuit Clamping

During short circuit the IGBT's gate voltage tends to rise because of the feedback via the Miller capacitance. An additional protection circuit connected to OUT+ limits this voltage to a value slightly higher than the supply voltage. A maximum current of 500 mA may be fed back to the supply through this path for 10 μ s. If higher currents are expected or tighter clamping is desired external Schottky diodes may be added.

4.4 Non-Inverting and Inverting Inputs

There are two possible input modes to control the IGBT. At non-inverting mode IN+ controls the driver output while IN- is set to low. At inverting mode IN- controls the driver output while IN+ is set to high, please see [Figure 7](#). A minimum input pulse width is defined to filter occasional glitches.

4.5 Driver Outputs

The output driver section uses MOSFETs to provide a rail-to-rail output. This feature permits that tight control of gate voltage during on-state and short circuit can be maintained as long as the driver's supply is stable. Due to the low internal voltage drop, switching behaviour of the IGBT is predominantly governed by the gate resistor. Furthermore, it reduces the power to be dissipated by the driver.

5 Electrical Parameters

5.1 Absolute Maximum Ratings

Note: Absolute maximum ratings are defined as ratings, which when being exceeded may lead to destruction of the integrated circuit. Unless otherwise noted all parameters refer to GND1.

Table 2 Absolute Maximum Ratings

Parameter	Symbol	Values		Unit	Note / Test Condition
		Min.	Max.		
Power supply output side	V_{VCC2}	-0.3	40	V	1)
Gate driver output	V_{OUT}	$V_{GND2}-0.3$	$V_{VCC2}+0.3$	V	–
Positive power supply input side	V_{VCC1}	-0.3	18.0	V	–
Logic input voltages (IN+,IN-)	$V_{LogicIN}$	-0.3	18.0	V	–
Input to output isolation voltage (GND2)	V_{ISO}	-1200	1200	V	
Junction temperature	T_J	-40	150	°C	–
Storage temperature	T_S	-55	150	°C	–
Power dissipation (Input side)	$P_{D, IN}$	–	25	mW	2) @ $T_A = 25^\circ\text{C}$
Power dissipation (Output side)	$P_{D, OUT}$	–	400	mW	2) @ $T_A = 25^\circ\text{C}$
Thermal resistance (Input side)	$R_{THJA, IN}$	–	145	K/W	2) @ $T_A = 85^\circ\text{C}$
Thermal resistance (Output side)	$R_{THJA, OUT}$	–	165	K/W	2) @ $T_A = 85^\circ\text{C}$
ESD capability	$V_{ESD, HBM}$	–	2	kV	Human Body Model ³⁾

1) With respect to GND2.

2) See [Figure 10](#) for reference layouts for these thermal data. Thermal performance may change significantly with layout and heat dissipation of components in close proximity.

3) According to EIA/JESD22-A114-C (discharging a 100 pF capacitor through a 1.5 kΩ series resistor).

5.2 Operating Parameters

Note: Within the operating range the IC operates as described in the functional description. Unless otherwise noted all parameters refer to GND1.

Table 3 Operating Parameters

Parameter	Symbol	Values		Unit	Note / Test Condition
		Min.	Max.		
Power supply output side	V_{VCC2}	13	35	V	1)
Power supply input side	V_{VCC1}	3.1	17	V	–
Logic input voltages (IN+, IN-)	$V_{LogicIN}$	-0.3	17	V	–
Switching frequency	f_{sw}	–	1.0	MHz	2) 3)
Ambient temperature	T_A	-40	125	°C	–
Thermal coefficient, junction-top	$\Psi_{th,jt}$	–	4.8	K/W	3) @ $T_A = 85^\circ\text{C}$
Common mode transient immunity (CMTI)	$ dV_{ISO}/dt $	–	100	kV/ μs	3) @ 1000 V

1) With respect to GND2.

2) do not exceed max. power dissipation

3) Parameter is not subject to production test - verified by design/characterization

5.3 Electrical Characteristics

Note: The electrical characteristics include the spread of values in supply voltages, load and junction temperatures given below. Typical values represent the median values at $T_A = 25^\circ\text{C}$. Unless otherwise noted all voltages are given with respect to their respective GND (GND1 for pins 1 to 3, GND2 for pins 5 to 7).

5.3.1 Voltage Supply

Table 4 Voltage Supply

Parameter	Symbol	Values			Unit	Note / Test Condition
		Min.	Typ.	Max.		
UVLO threshold input chip	V_{UVLOH1}	–	2.85	3.1	V	–
	V_{UVLOL1}	2.55	2.75	–	V	–
UVLO hysteresis input chip ($V_{UVLOH1} - V_{UVLOL1}$)	V_{HYS1}	90	100	–	mV	–
UVLO threshold output chip (IGBT supply)	V_{UVLOH2}	–	12.0	12.7	V	–
	V_{UVLOL2}	10.5	11.1	–	V	–
UVLO hysteresis output chip ($V_{UVLOH2} - V_{UVLOL2}$)	V_{HYS2}	700	850	–	mV	–

Table 4 Voltage Supply (cont'd)

Parameter	Symbol	Values			Unit	Note / Test Condition
		Min.	Typ.	Max.		
Quiescent current input chip	I_{Q1}	–	0.65	1.0	mA	$V_{VCC1} = 5\text{ V}$ IN+ = High, IN- = Low =>OUT = High
Quiescent current output chip	I_{Q2}	–	1.2	2.0	mA	$V_{VCC2} = 15\text{ V}$ IN+ = High, IN- = Low =>OUT = High

5.3.2 Logic Input

Note: Unless stated otherwise $V_{CC1} = 5.0\text{V}$

Table 5 Logic Input

Parameter	Symbol	Values			Unit	Note / Test Condition
		Min.	Typ.	Max.		
IN+,IN- low input voltage	V_{IN+L}, V_{IN-L}	–	–	30	%	of VCC1
IN+,IN- high input voltage	V_{IN+H}, V_{IN-H}	70	–	–	%	of VCC1
IN+,IN- low input voltage	V_{IN+L}, V_{IN-L}	–	–	1.5	V	–
IN+,IN- high input voltage	V_{IN+H}, V_{IN-H}	3.5	–	–	V	–
IN- input current	I_{IN-}	–	70	200	μA	$V_{IN-} = \text{GND1}$
IN+ input current	I_{IN+}	–	70	200	μA	$V_{IN+} = V_{CC1}$

5.3.3 Gate Driver

Table 6 Gate Driver

Parameter	Symbol	Values			Unit	Note / Test Condition
		Min.	Typ.	Max.		
High level output peak current (source) 1EDI05I12AF 1EDI20I12AF 1EDI40I12AF 1EDI60I12AF	$I_{OUT+,PEAK}$	0.5 2.0 4.0 6.0	– 1.3 4.0 7.5 10.0	–	A	1) IN+ = High, IN- = Low, $V_{VCC2} = 15\text{ V}$
Low level output peak current (sink) 1EDI05I12AF 1EDI20I12AF 1EDI40I12AF 1EDI60I12AF	$I_{OUT-,PEAK}$	0.5 2.0 4.0 6.0	– 0.9 3.5 6.8 9.4	–	A	1) IN+ = Low, IN- = Low, $V_{VCC2} = 15\text{ V}$

1) voltage across the device $V_{(VCC2 - OUT+)}$ or $V_{(OUT- - GND2)} < V_{VCC2}$.

5.3.4 Short Circuit Clamping

Table 7 Short Circuit Clamping

Parameter	Symbol	Values			Unit	Note / Test Condition
		Min.	Typ.	Max.		
Clamping voltage (OUT+) ($V_{OUT} - V_{VCC2}$)	V_{CLPout}	–	0.9	1.3	V	IN+ = High, IN- = Low, OUT = High $I_{OUT} = 500$ mA pulse test, $t_{CLPmax} = 10$ μ s)

5.3.5 Dynamic Characteristics

Dynamic characteristics are measured with $V_{VCC1} = 5$ V and $V_{VCC2} = 15$ V.

Table 8 Dynamic Characteristics

Parameter	Symbol	Values			Unit	Note / Test Condition
		Min.	Typ.	Max.		
Input IN to output propagation delay ON	T_{PDON}	270	300	330	ns	$C_{LOAD} = 100$ pF $V_{IN+} = 50\%$, $V_{OUT} = 50\%$ @ 25°C
Input IN to output propagation delay OFF	T_{PDOFF}	270	300	330	ns	
Input IN to output propagation delay distortion ($T_{PDOFF} - T_{PDON}$)	T_{PDISTO}	-30	5	40	ns	
Input pulse suppression IN+, IN-	T_{MININ+} , T_{MININ-}	230	240	–	ns	–
Input IN to output propagation delay ON variation due to temp	T_{PDONT}	–	–	14	ns	¹⁾ $C_{LOAD} = 100$ pF $V_{IN+} = 50\%$, $V_{OUT} = 50\%$
Input IN to output propagation delay OFF variation due to temp	T_{PDOFFt}	–	–	14	ns	¹⁾ $C_{LOAD} = 100$ pF $V_{IN+} = 50\%$, $V_{OUT} = 50\%$
Input IN to output propagation delay distortion variation due to temp ($T_{PDOFF} - T_{PDON}$)	$T_{PDISTOt}$	–	–	8	ns	¹⁾ $C_{LOAD} = 100$ pF $V_{IN+} = 50\%$, $V_{OUT} = 50\%$
Rise time	T_{RISE}	5	10	20	ns	$C_{LOAD} = 1$ nF $V_L 20\%$, $V_H 80\%$
Fall time	T_{FALL}	4	9	19	ns	$C_{LOAD} = 1$ nF $V_L 20\%$, $V_H 80\%$

1) The parameter is not subject to production test - verified by design/characterization

5.3.6 Active Shut Down

Table 9 Active Shut Down

Parameter	Symbol	Values			Unit	Note / Test Condition
		Min.	Typ.	Max.		
Active shut down voltage	$V_{ACTSD}^{1)}$	–	2.2	2.5	V	$I_{OUT}/I_{OUT,PEAK}=0.1$, V_{CC2} open

1) With reference to GND2

6 Timing Diagramms

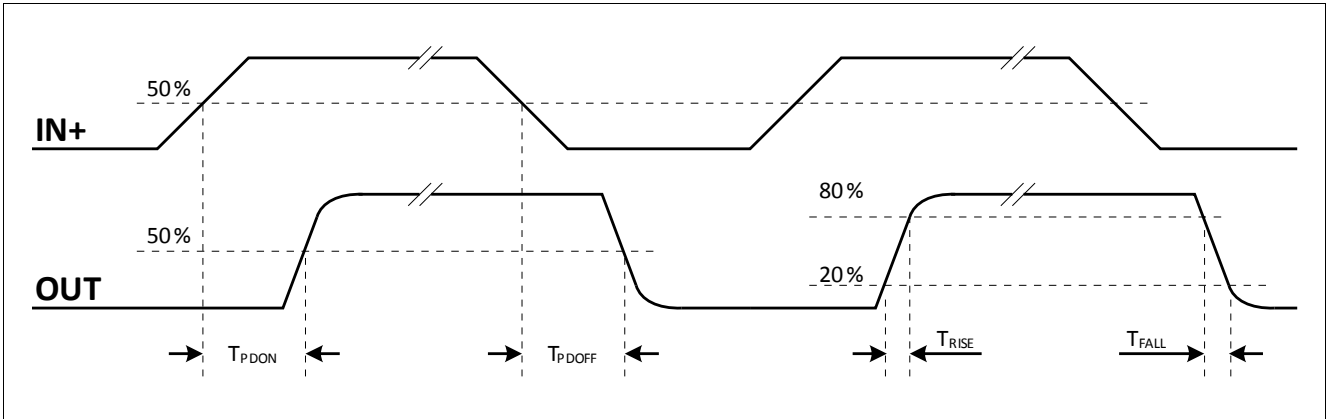

Figure 6 Propagation Delay, Rise and Fall Time

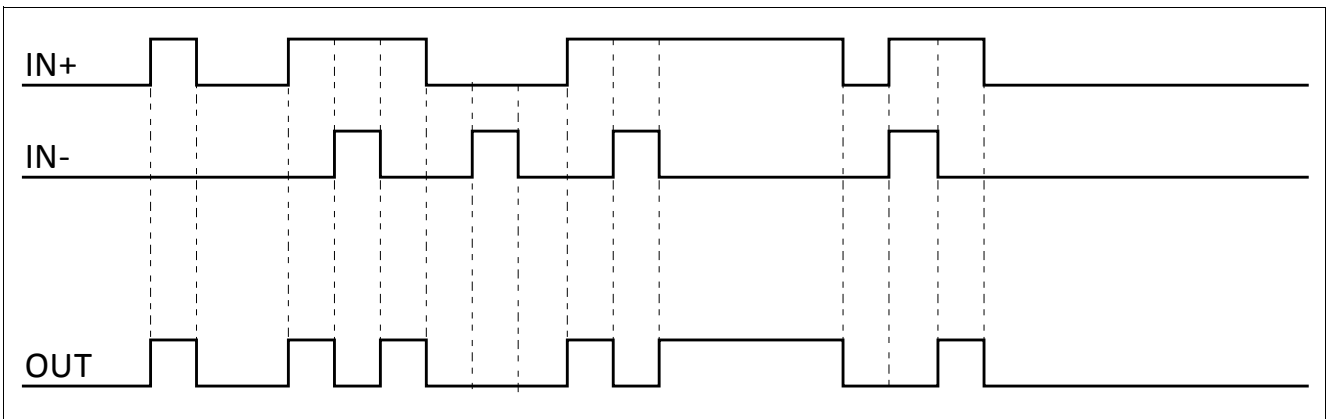

Figure 7 Typical Switching Behavior

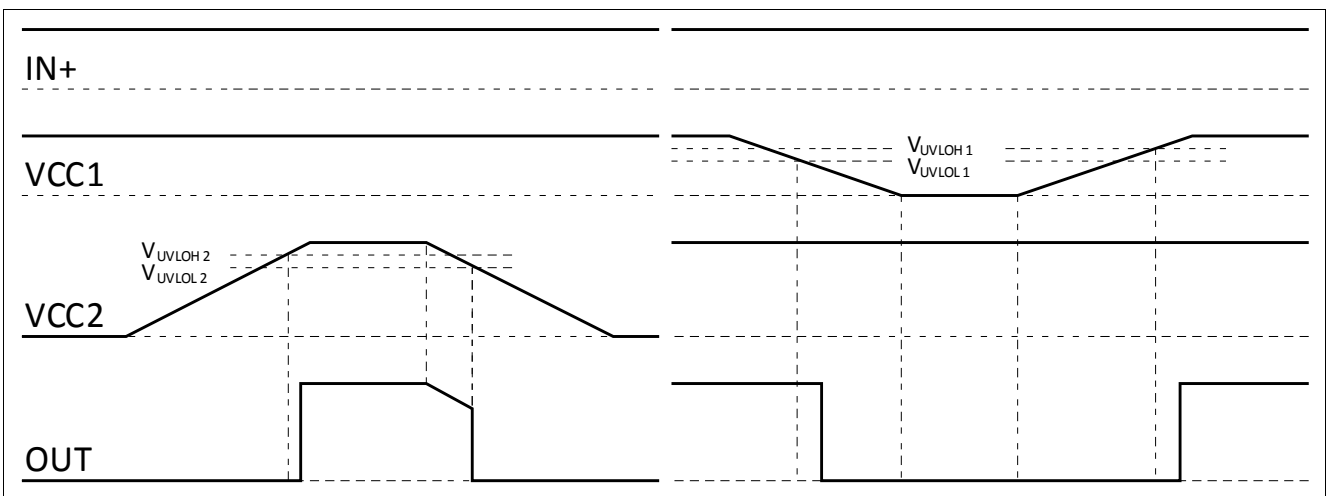

Figure 8 UVLO Behavior

7 Package Outlines

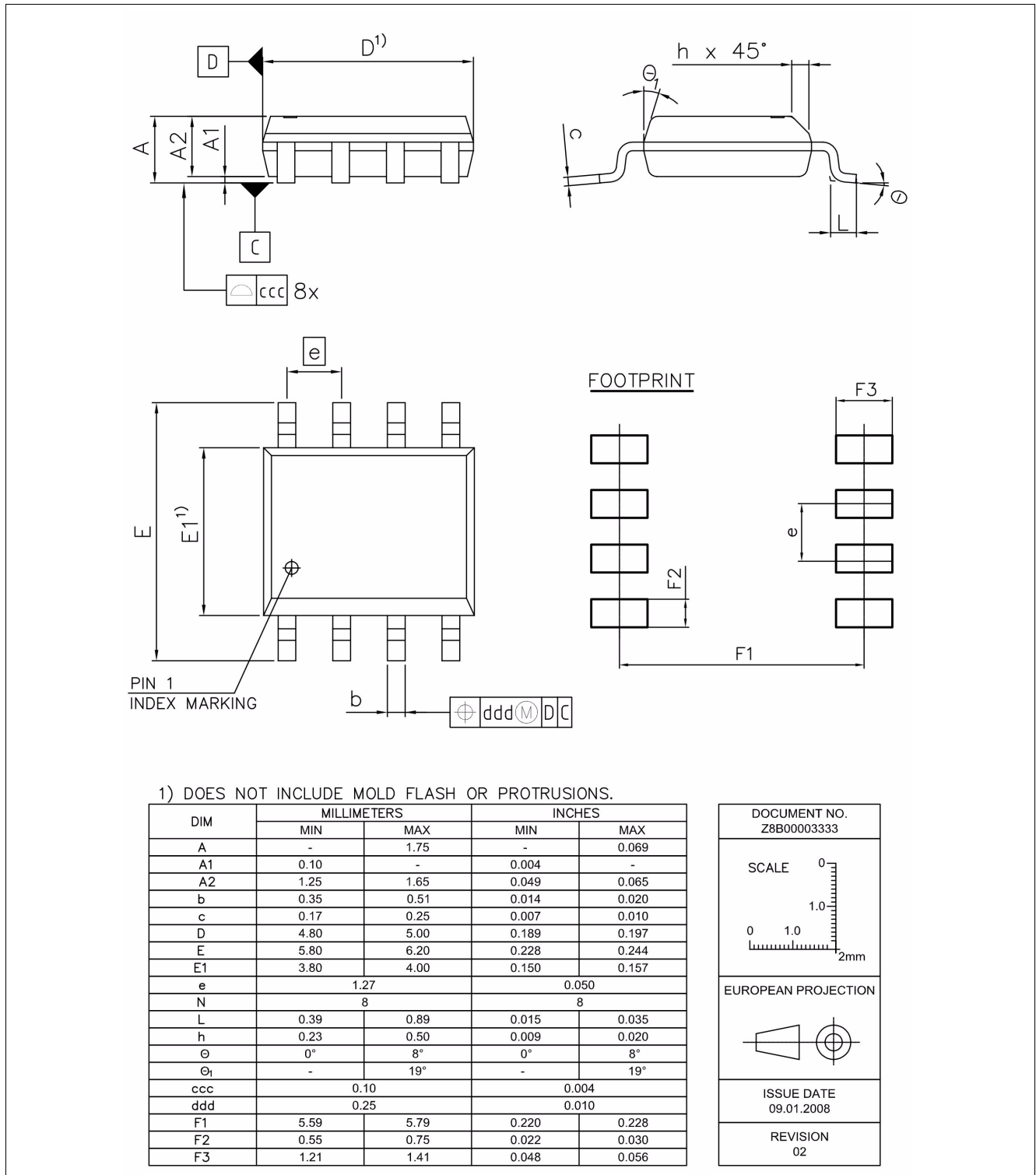

Figure 9 PG-DSO-8-51 (Plastic (Green) Dual Small Outline Package)

8 Application Notes

8.1 Reference Layout for Thermal Data

The PCB layout shown in **Figure 10** represents the reference layout used for the thermal characterisation. Pin 4 (GND1) and pin 8 (GND2) require each a ground plane of 100 mm² for achieving maximum power dissipation. The Separate output variant for IGBT is conceived to dissipate most of the heat generated through these pins.

The thermal coefficient junction-top ($\Psi_{th,jt}$) can be used to calculate the junction temperature at a given top case temperature and driver power dissipation:

$$T_j = \Psi_{th,jt} \cdot P_D + T_{top}$$

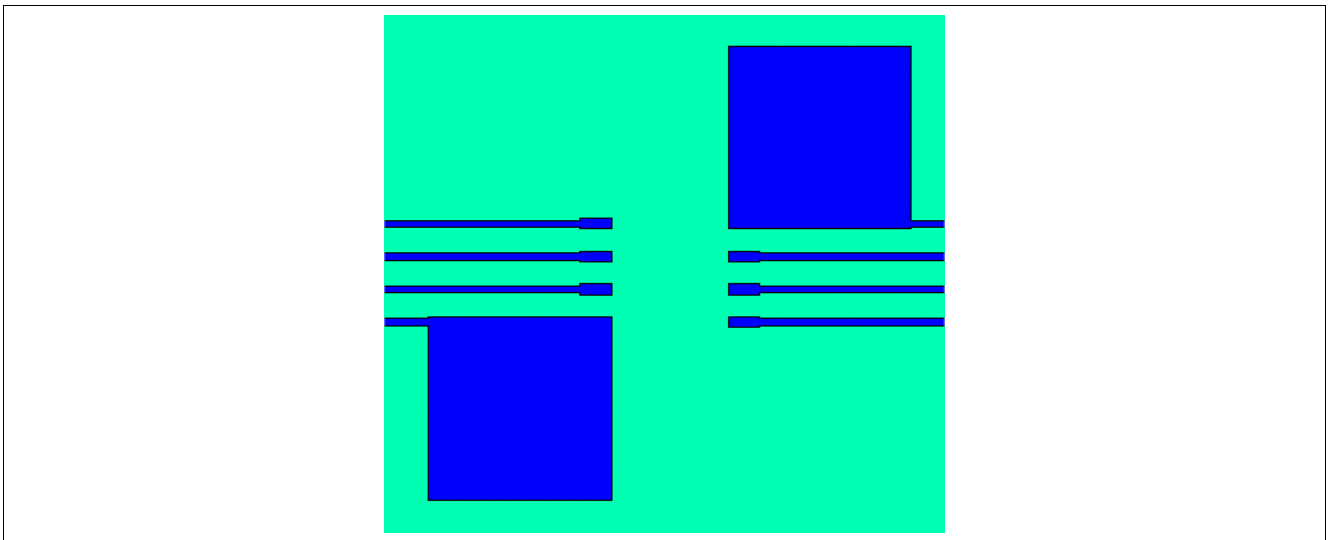

Figure 10 Reference Layout for Thermal Data (JEDEC 1s0p, 100mm², Copper thickness 35 μm)

8.2 Printed Circuit Board Guidelines

The following factors should be taken into account for an optimum PCB layout.

- Sufficient spacing should be kept between high voltage isolated side and low voltage side circuits.
- The same minimum distance between two adjacent high-side isolated parts of the PCB should be maintained to increase the effective isolation and to reduce parasitic coupling.
- In order to ensure low supply ripple and clean switching signals, bypass capacitor trace lengths should be kept as short as possible.

www.infineon.com

Published by Infineon Technologies AG