



Chipsmall Limited consists of a professional team with an average of over 10 year of expertise in the distribution of electronic components. Based in Hongkong, we have already established firm and mutual-benefit business relationships with customers from,Europe,America and south Asia,supplying obsolete and hard-to-find components to meet their specific needs.

With the principle of “Quality Parts,Customers Priority,Honest Operation,and Considerate Service”,our business mainly focus on the distribution of electronic components. Line cards we deal with include Microchip,ALPS,ROHM,Xilinx,Pulse,ON,Everlight and Freescale. Main products comprise IC,Modules,Potentiometer,IC Socket,Relay,Connector.Our parts cover such applications as commercial,industrial, and automotives areas.

We are looking forward to setting up business relationship with you and hope to provide you with the best service and solution. Let us make a better world for our industry!



## Contact us

Tel: +86-755-8981 8866 Fax: +86-755-8427 6832

Email & Skype: info@chipsmall.com Web: www.chipsmall.com

Address: A1208, Overseas Decoration Building, #122 Zhenhua RD., Futian, Shenzhen, China



## Important notice

Dear Customer,

On 7 February 2017 the former NXP Standard Product business became a new company with the tradename **Nexperia**. Nexperia is an industry leading supplier of Discrete, Logic and PowerMOS semiconductors with its focus on the automotive, industrial, computing, consumer and wearable application markets

In data sheets and application notes which still contain NXP or Philips Semiconductors references, use the references to Nexperia, as shown below.

Instead of <http://www.nxp.com>, <http://www.philips.com/> or <http://www.semiconductors.philips.com/>, use <http://www.nexperia.com>

Instead of [sales.addresses@www.nxp.com](mailto:sales.addresses@www.nxp.com) or [sales.addresses@www.semiconductors.philips.com](mailto:sales.addresses@www.semiconductors.philips.com), use [salesaddresses@nexperia.com](mailto:salesaddresses@nexperia.com) (email)

Replace the copyright notice at the bottom of each page or elsewhere in the document, depending on the version, as shown below:

- © NXP N.V. (year). All rights reserved or © Koninklijke Philips Electronics N.V. (year). All rights reserved

Should be replaced with:

- © **Nexperia B.V. (year). All rights reserved.**

If you have any questions related to the data sheet, please contact our nearest sales office via e-mail or telephone (details via [salesaddresses@nexperia.com](mailto:salesaddresses@nexperia.com)). Thank you for your cooperation and understanding,

Kind regards,

Team Nexperia

# DATA SHEET

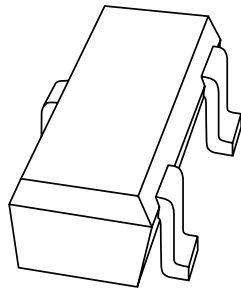

## **1PS59SB10 series** Schottky barrier (double) diodes

Product specification

1996 Sep 20

# Schottky barrier (double) diodes

# 1PS59SB10 series

### FEATURES

- Low forward voltage
- Guard ring protected
- Small SMD package.

### APPLICATIONS

- Ultra high-speed switching
- Voltage clamping
- Protection circuits
- Blocking diodes.

### DESCRIPTION

Planar Schottky barrier diodes encapsulated in a SC59 small plastic SMD package. Single diodes and double diodes with different pinning are available.

### MARKING

TYPE NUMBER	MARKING CODE
1PS59SB10	10
1PS59SB14	14
1PS59SB15	15
1PS59SB16	16

### PINNING

PIN	1PS59SB. .			
	10	14	15	16
1	a	a <sub>1</sub>	a <sub>1</sub>	k <sub>1</sub>
2	n.c.	k <sub>2</sub>	a <sub>2</sub>	k <sub>2</sub>
3	k	k <sub>1</sub> , a <sub>2</sub>	k <sub>1</sub> , k <sub>2</sub>	a <sub>1</sub> , a <sub>2</sub>

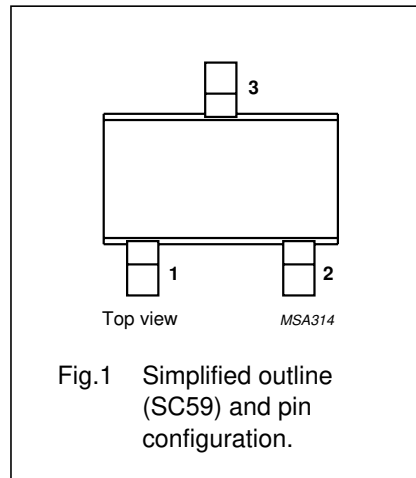

Fig.1 Simplified outline (SC59) and pin configuration.

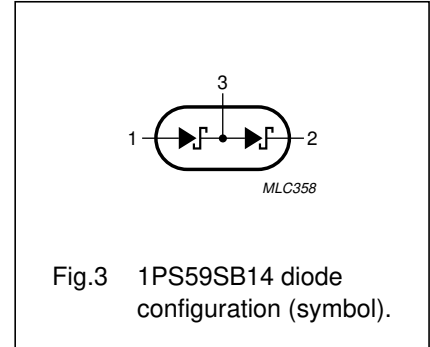

Fig.3 1PS59SB14 diode configuration (symbol).

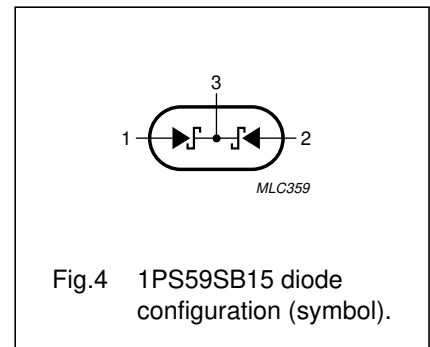

Fig.4 1PS59SB15 diode configuration (symbol).

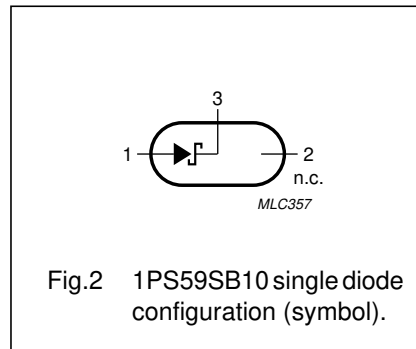

Fig.2 1PS59SB10 single diode configuration (symbol).

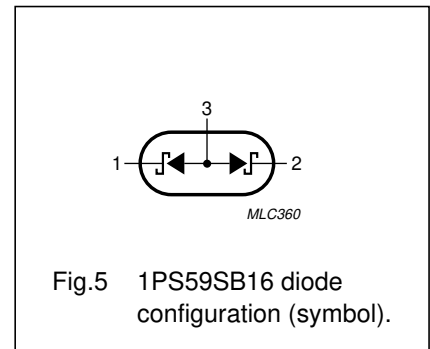

Fig.5 1PS59SB16 diode configuration (symbol).

## Schottky barrier (double) diodes

## 1PS59SB10 series

**LIMITING VALUES**

In accordance with the Absolute Maximum Rating System (IEC 134).

SYMBOL	PARAMETER	CONDITIONS	MIN.	MAX.	UNIT
<b>Per diode</b>					
$V_R$	continuous reverse voltage		–	30	V
$I_F$	continuous forward current		–	200	mA
$I_{FRM}$	repetitive peak forward current	$t_p \leq 1$ s; $\delta \leq 0.5$	–	300	mA
$I_{FSM}$	non-repetitive peak forward current	$t_p < 10$ ms	–	600	mA
$P_{tot}$	total power dissipation (per package)	$T_{amb} \leq 25$ °C	–	250	mW
$T_{stg}$	storage temperature		–65	+150	°C
$T_j$	junction temperature		–	125	°C

**ELECTRICAL CHARACTERISTICS**

$T_{amb} = 25$  °C unless otherwise specified.

SYMBOL	PARAMETER	CONDITIONS	MAX.	UNIT
<b>Per diode</b>				
$V_F$	forward voltage	see Fig.6 $I_F = 0.1$ mA $I_F = 1$ mA $I_F = 10$ mA $I_F = 30$ mA $I_F = 100$ mA	240 320 400 500 800	mV mV mV mV mV
$I_R$	reverse current	$V_R = 25$ V; see Fig.7	2	$\mu$ A
$t_{rr}$	reverse recovery time	when switched from $I_F = 10$ mA to $I_R = 10$ mA; $R_L = 100$ $\Omega$ ; measured at $I_R = 1$ mA; see Fig.9	5	ns
$C_d$	diode capacitance	$f = 1$ MHz; $V_R = 1$ V; see Fig.8	10	pF

**THERMAL CHARACTERISTICS**

SYMBOL	PARAMETER	CONDITIONS	VALUE	UNIT
$R_{th\ j-a}$	thermal resistance from junction to ambient	note 1	500	K/W

**Note**

1. Refer to SC59 standard mounting conditions.

Schottky barrier (double) diodes

1PS59SB10 series

GRAPHICAL DATA

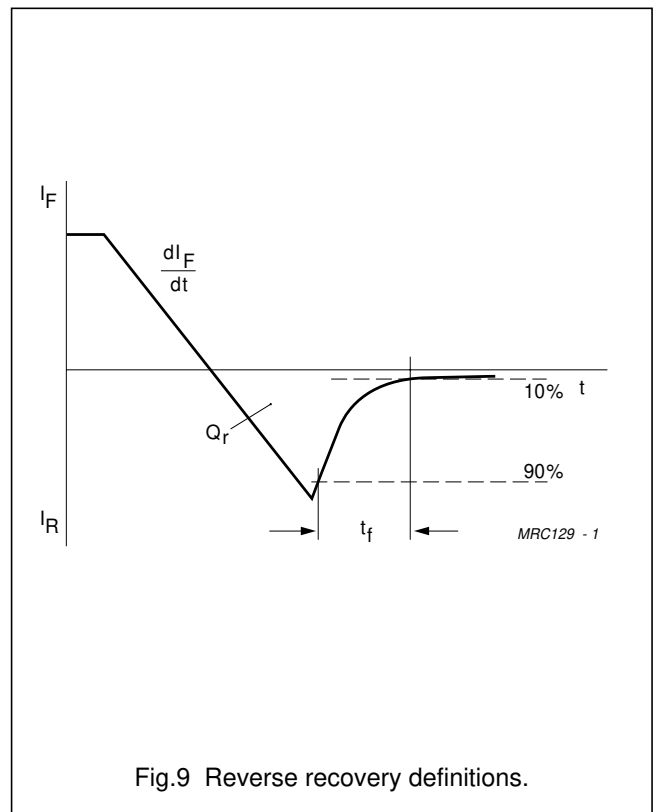
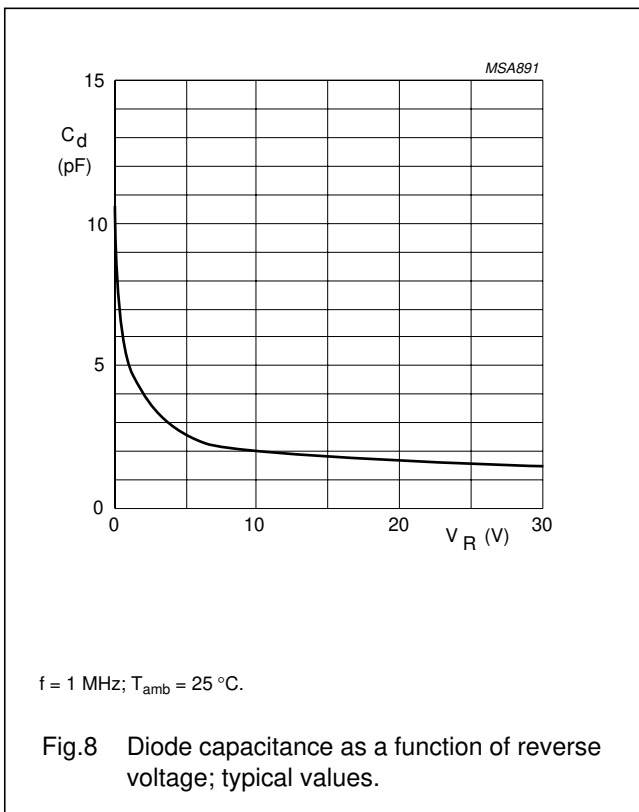
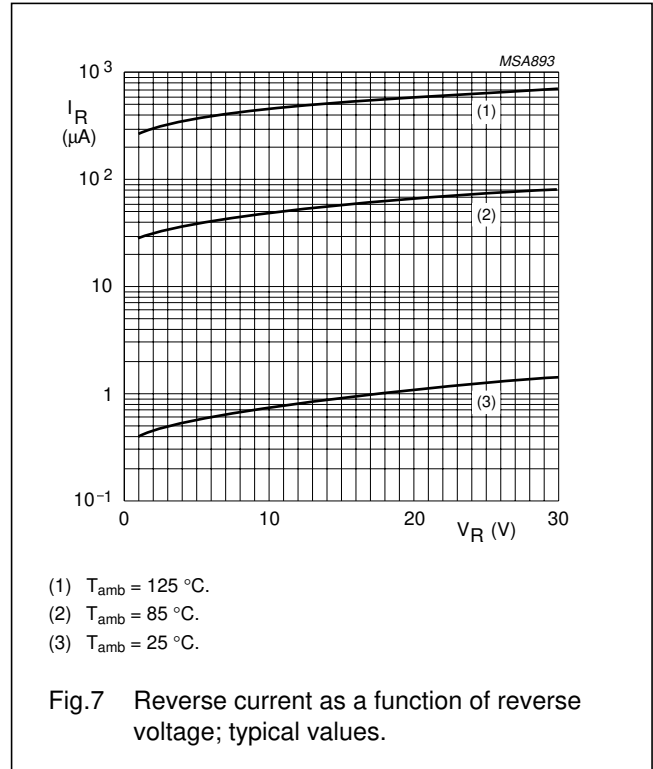
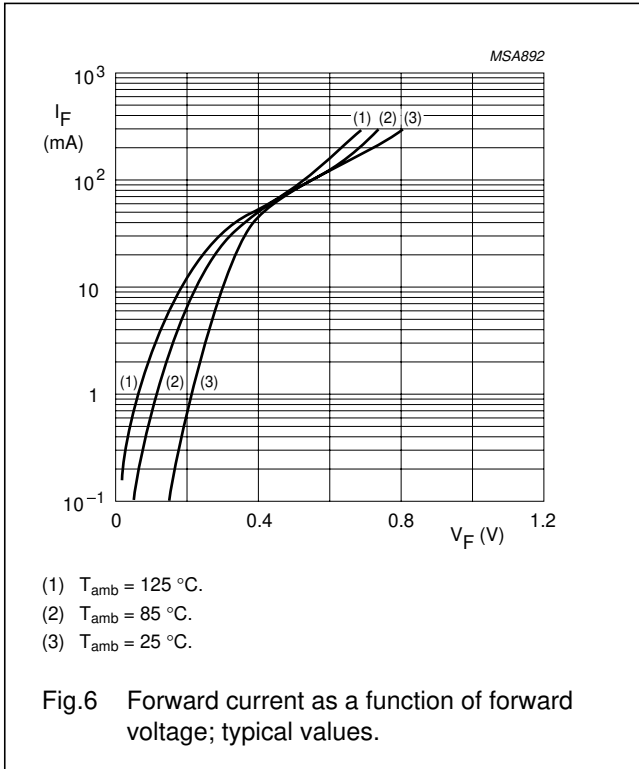

Schottky barrier (double) diodes

1PS59SB10 series

PACKAGE OUTLINE

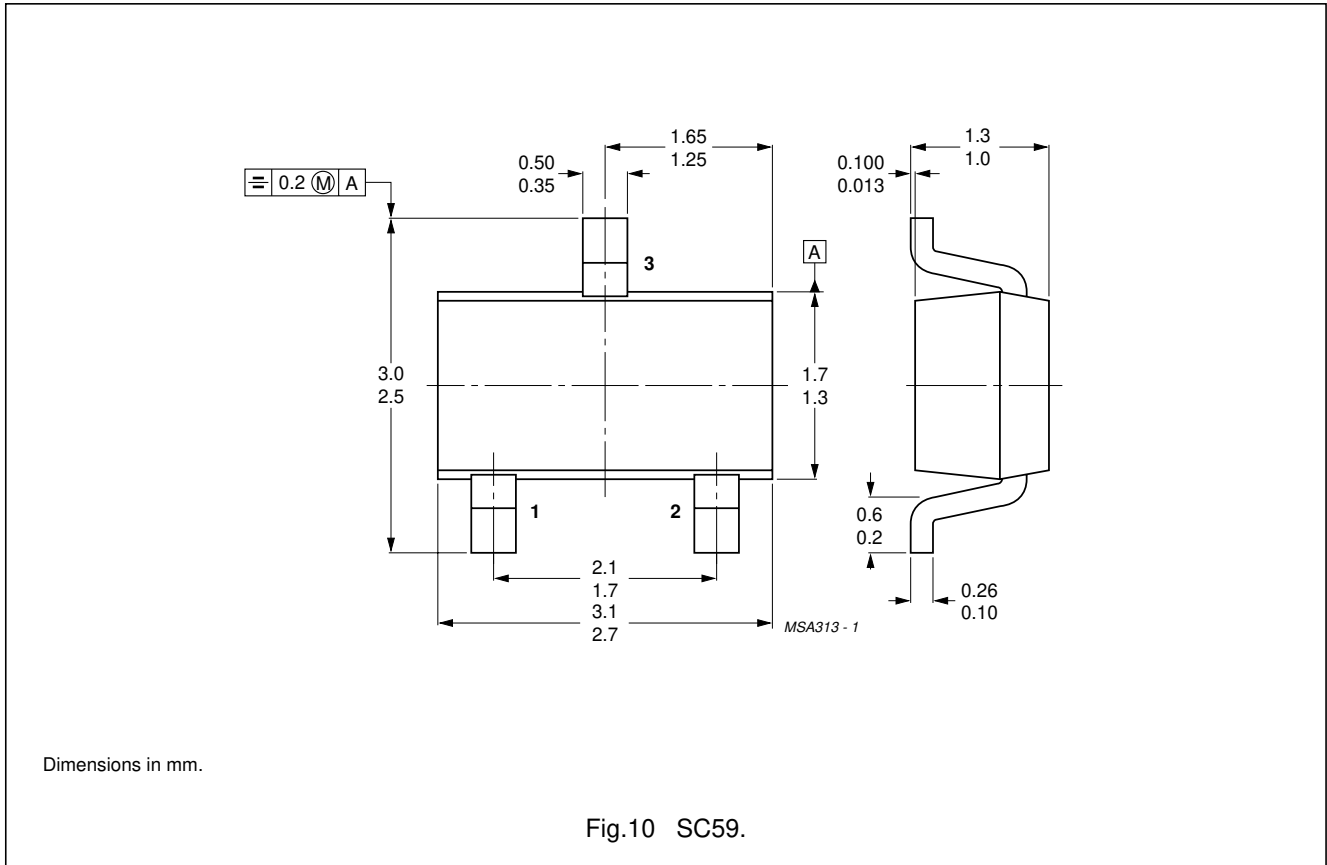

DEFINITIONS

<b>Data sheet status</b>	
Objective specification	This data sheet contains target or goal specifications for product development.
Preliminary specification	This data sheet contains preliminary data; supplementary data may be published later.
Product specification	This data sheet contains final product specifications.
<b>Limiting values</b>	
Limiting values given are in accordance with the Absolute Maximum Rating System (IEC 134). Stress above one or more of the limiting values may cause permanent damage to the device. These are stress ratings only and operation of the device at these or at any other conditions above those given in the Characteristics sections of the specification is not implied. Exposure to limiting values for extended periods may affect device reliability.	
<b>Application information</b>	
Where application information is given, it is advisory and does not form part of the specification.	

LIFE SUPPORT APPLICATIONS

These products are not designed for use in life support appliances, devices, or systems where malfunction of these products can reasonably be expected to result in personal injury. Philips customers using or selling these products for use in such applications do so at their own risk and agree to fully indemnify Philips for any damages resulting from such improper use or sale.