



Chipsmall Limited consists of a professional team with an average of over 10 year of expertise in the distribution of electronic components. Based in Hongkong, we have already established firm and mutual-benefit business relationships with customers from,Europe,America and south Asia,supplying obsolete and hard-to-find components to meet their specific needs.

With the principle of "Quality Parts,Customers Priority,Honest Operation,and Considerate Service",our business mainly focus on the distribution of electronic components. Line cards we deal with include Microchip,ALPS,ROHM,Xilinx,Pulse,ON,Everlight and Freescale. Main products comprise IC,Modules,Potentiometer,IC Socket,Relay,Connector.Our parts cover such applications as commercial,industrial, and automotives areas.

We are looking forward to setting up business relationship with you and hope to provide you with the best service and solution. Let us make a better world for our industry!



## Contact us

Tel: +86-755-8981 8866 Fax: +86-755-8427 6832

Email & Skype: info@chipsmall.com Web: www.chipsmall.com

Address: A1208, Overseas Decoration Building, #122 Zhenhua RD., Futian, Shenzhen, China



# 1SD1548AI UL Single-Channel High-Power SCALE Driver Core

## Description

The SCALE driver 1SD1548AI UL from CONCEPT is based on a chip set that was developed specifically for the reliable driving and safe operation of IGBTs and power MOSFETs.

The SCALE driver 1SD1548AI UL features a high gate current of  $\pm 48A$  and a high power of 15W. It has been specially developed for high-frequency applications (e.g. resonant converters) with a high gate-power requirement or for high gate-current driving applications (e.g. parallel connection of high-power IGBT modules).



## Product Highlights

- ✓ Suitable for 1200V and 1700V IGBTs
- ✓ Short-circuit and over-current protection
- ✓ Extremely reliable, long service life
- ✓ High gate current of  $\pm 48A$
- ✓ Electrical insulation of  $4000V_{AC}$
- ✓ Electrically insulated status acknowledgement
- ✓ Monitoring of power supply and self-monitoring
- ✓ Switching frequency DC to 150kHz
- ✓ Duty cycle: 0... 100%
- ✓ High dv/dt immunity, typical  $> 100kV/\mu s$
- ✓ Complete with built-in 15W DC/DC converter
- ✓ UL compliant

## Applications

- ✓ Inverters
- ✓ Motor drive technology
- ✓ Traction
- ✓ Railroad power supplies
- ✓ Converters
- ✓ Power engineering
- ✓ Switched-mode power supplies
- ✓ Radiology and laser technology
- ✓ DC/DC converters
- ✓ Research
- ✓ RF generators and converters

## Data Sheet

### Block Diagram

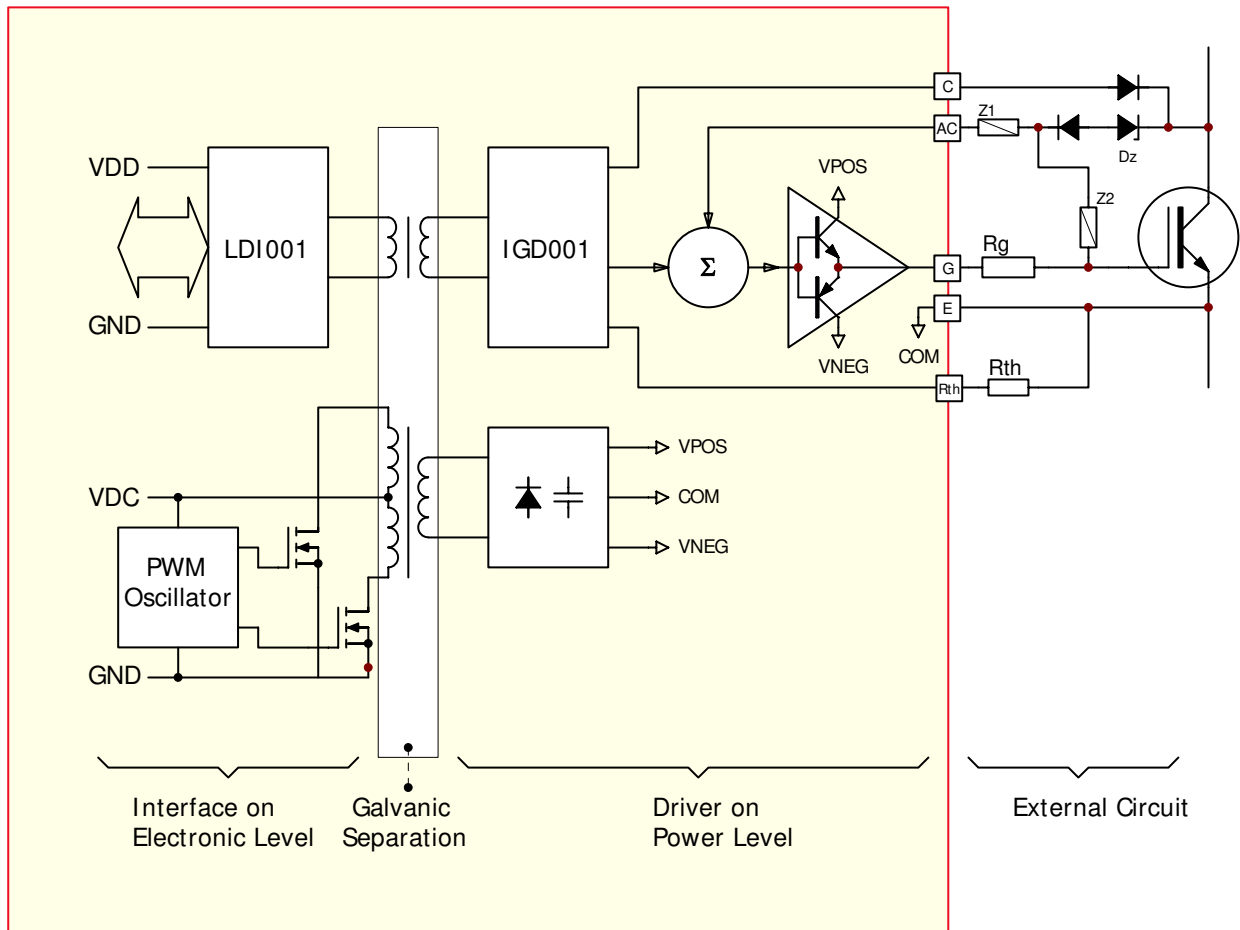

Fig. 1 Block diagram of the 1SD1548AI UL

### Pin Designation

Pin	Des.	Function	Pin	Des.	Function
1	VDD	+ 15V for electronic input side	44	VPOS	Blocking capacitor +15V
2	VDD	+ 15V for electronic input side	43	COM	Common
3	VDD	+ 15V for electronic input side	42	VNEG	Blocking capacitor -15V
4	SO	Status output	41	E	Emitter
5	VL	Logic level/Reset	40	G	Gate
6	In	Input	39	E	Emitter
7	GND	Ground	38	G	Gate
8	GND	Ground	37	E	Emitter
9	GND	Ground	36	G	Gate
10	GND	Ground	35	AC	Enhanced active clamping
11	GND	Ground	34	Rth	Reference resistor
12	GND	Ground	33	C	Collector sense
13	GND	Ground	32	LS	Local status
14	VDC	+ 15V for DC/DC converter	31	E	Emitter
15	VDC	+ 15V for DC/DC converter	30	G	Gate
16	VDC	+ 15V for DC/DC converter	29	E	Emitter
17	VDC	+ 15V for DC/DC converter	28	G	Gate
18	VDC	+ 15V for DC/DC converter	27	E	Emitter
19	VDC	+ 15V for DC/DC converter	26	G	Gate
20	Free		25	VPOS	Blocking capacitor +15V
21	VDC	+ 15V for DC/DC converter	24	COM	Common
22	VDC	+ 15V for DC/DC converter	23	VNEG	Blocking capacitor -15V

### Notes:

- 1) Pins with the designation "Free" are not physically present.
- 2) E (Emitter) is directly connected to COM (same potential).
- 3) AC should be connected to VNEG if not used (normal case)

### PCB Layout / Dimensions

#### Details of circuit board layout

Grid of the aspect drawing on page 4 below: 1.27mm (50mil)

Recommended diameter of solder pad: Ø 1.52mm

Recommended diameter of drill holes: Ø 1.1mm

## Data Sheet

## Dimensions

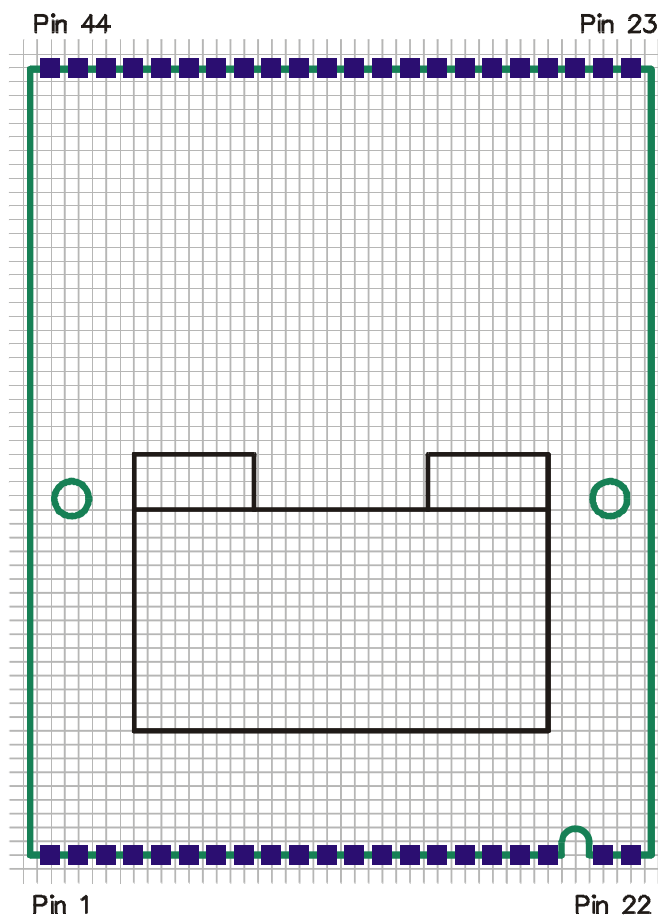
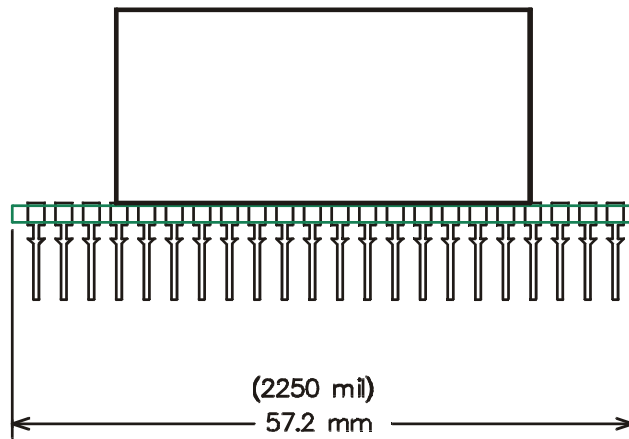

Fig 2 Front view (top) / Layout overview component side (bottom) 1SD1548AI UL

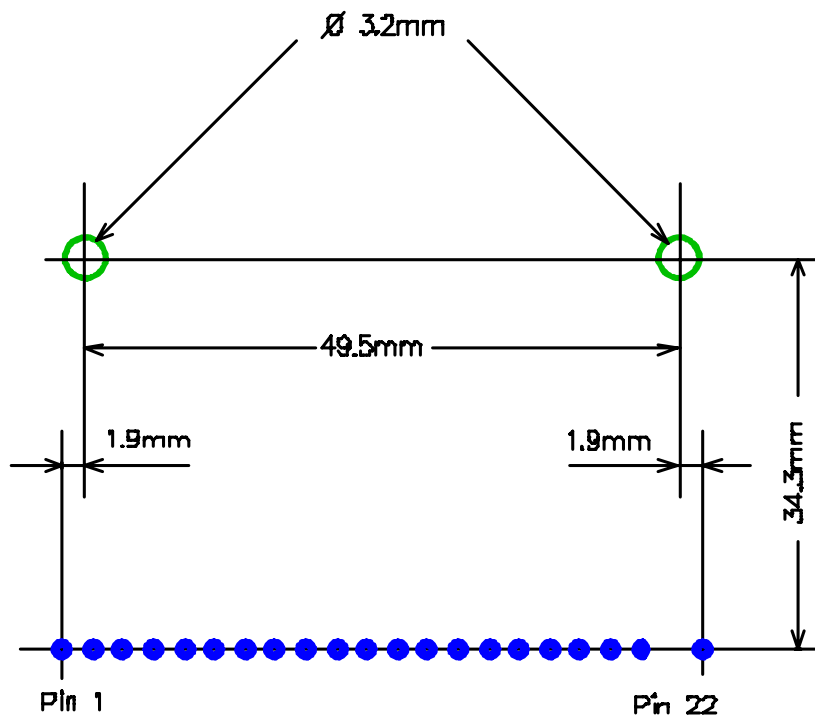
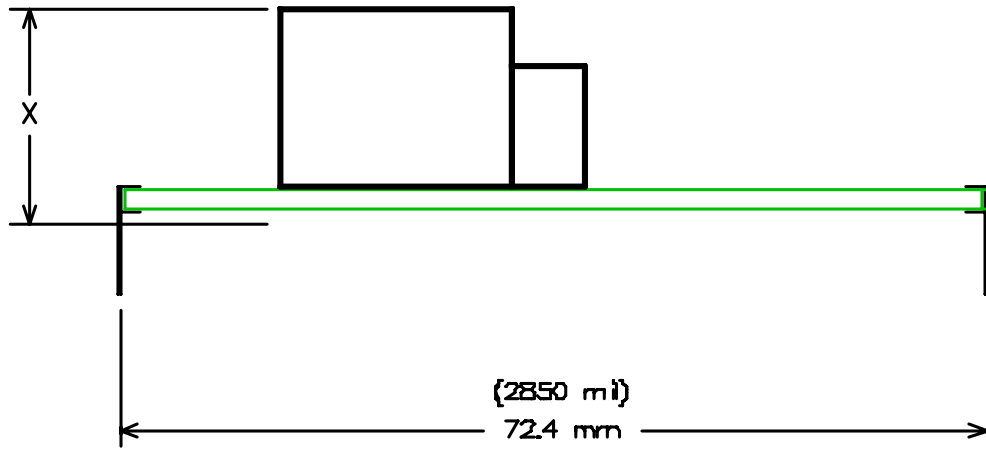

Fig. 3 Side view (top) / Mechanical fixing (bottom) 1SD1548AI UL

Height X: typ. 19mm

## Data Sheet

**Mechanical fixing**

The 1SD1548AI UL driver has two holes, each 3.2mm in diameter. They allow additional fixing of the driver for applications requiring very high resistance to shaking/vibration (railways, traction systems, electrically-driven vehicles, etc.). See Fig. 3 (bottom).

**Absolute Maximum Ratings**

Parameter	Test conditions	Min	Max	Units
Supply voltage $V_{DC}$		0	16	$V_{dc}$
Supply voltage $V_{DD}$		0	16	$V_{dc}$
Logic input voltage	To GND (Note 5)	0	$V_{DD}$	$V_{dc}$
Gate peak current $I_G$	G to E	-48	+48	A
Output power DC/DC converter			15	W
Operating voltage	Continuous (Note 8)		1700	$V_{dc}$
Test voltage (50Hz/1min)	Inputs to outputs		4000	$V_{AC(eff)}$
Operating temperature	Note 10	-40	+85	$^{\circ}C$
Storage temperature		-40	+90	$^{\circ}C$

All data refer to +25 $^{\circ}C$  and  $V_{DD} = V_{DC} = 15V$  unless otherwise specified

**Electrical Characteristics**

Power supply	Test conditions	Min	Typ.	Max	Units
Nominal supply voltage $V_{DC}$	To GND (Note 1)	15			$V_{dc}$
Supply current $I_{DC}$	Without load	55			mA
Max. supply current $I_{DC}$	Note 2			1200	mA
Output power DC/DC converter	Note 3			15	W
Efficiency $\eta$	Internal DC/DC converter, full load	90			%
Nominal supply voltage $V_{DD}$	To GND	15			$V_{dc}$
Supply current $I_{DD}$	Without load	10			mA
Supply current $I_{DD}$	At 50kHz switching frequency	14			mA

### Electrical Characteristics (Continuation)

Power supply monitoring	Test conditions	Min	Typ.	Max	Units
Turn-on threshold $V_{th}$	Note 4		11.4		$V_{dc}$
Hysteresis on/off	Note 4		0.8		$V_{dc}$
Logic inputs	Test conditions	Min	Typ.	Max	Units
Input voltage	All inputs (Note 5)	0		$V_{DD}$	$V_{dc}$
Timing characteristics	Test conditions	Min	Typ.	Max	Units
Delay time input to output	Turn-on $t_{pd(on)}$		335		ns
	Turn-off $t_{pd(off)}$		420		ns
Blocking time	After failure (Note 13)		1		s
Outputs	Test conditions	Min	Typ.	Max	Units
Output current $I_G$	G to E (Note 6)	-48		+ 48	A
Output rise time $t_{r(out)}$	G to E (Note 7)		20/85		ns
Output fall time $t_{f(out)}$	G to E (Note 7)		20/60		ns
Output current SO		1.5			mA
Output voltage rating SO	SO to GND			$V_{DD}$	V
Output current LS		5			mA
$V_{ce}$ monitoring	Test conditions	Min	Typ.	Max	Units
Input C	To E	0		$V_{DD}$	$V_{dc}$
Electrical insulation	Test conditions	Min	Typ.	Max	Units
Operating voltage	Continuous (Note 8)			1700	$V_{dc}$
Test voltage	50Hz/1min (Note 12)			4000	$V_{AC(eff)}$
Partial discharge extinction volt.	IEC270 (Note 11)		> 1700		$V_{AC(pk)}$
Creep path input-output			20		mm
Maximum $\Delta V/\Delta t$ at $\Delta V=1000V$	Note 9		100		$kV/\mu s$

All data refer to +25°C and  $V_{DD} = V_{DC} = 15V$  unless otherwise specified



## Data Sheet

<b>Operating Conditions</b>
-----------------------------

Operating conditions	Test conditions	Min	Max	Units
Operating temperature	Note 10	-40	+ 85	°C
Storage temperature		-40	+ 90	°C

**Footnotes to the key data**

- 1) The drivers have a zener diode on the secondary side between VPOS – COM and COM – VNEG for over-voltage protection. When the feed voltage exceeds 16V, this protection can be subject to thermal overload.
- 2) If the specified power consumption is exceeded, this indicates an overload of the DC/DC converter. It should be noted that the DC/DC converter is not protected against overload.
- 3) This should be considered as a recommended value. Please consult the section: “Output power and self-heating”. Especially when the drivers produce continuously short pulses (on-time or off-time < 1.5µs), their self-heating can be considerably increased. The maximum power of the drivers should be reduced in this case.
- 4) Under-voltage monitoring for protecting the power semiconductors. The voltage refers to the local supply voltage VPOS. However, this corresponds approximately to the voltage at VDC with respect to GND.
- 5) The input levels must never exceed the limits of the supply voltage (i.e. between GND and VDD), otherwise latch-up of the integrated circuits LDI001 can occur. Particular care must be taken when driving via cables or longer leads. See also application note AN-9901 on [www.IGBT-Driver.com](http://www.IGBT-Driver.com).
- 6) The gate current must be limited to its maximum value by a gate resistor.
- 7) First value: At a load of 94nF in series with 1.95Ω. Second value: At a load of 660nF in series with 0.6 Ω
- 8) Maximum continuous or repeatedly applied DC voltage or peak value of the repeatedly applied AC voltage between all inputs and all outputs. However, types that have been measured and selected for higher partial-discharge voltages are also available (see note 11).
- 9) This specification guarantees that the drive information will be transferred reliably even at a high DC-link voltage and fastest switching operations.
- 10) The application-specific self-heating of the drivers – especially at high load – must be taken into account.
- 11) The partial discharge is not measured for the standard types. Tested and selected types with guaranteed partial-discharge immunity can be supplied for applications with maximum requirements and higher operating voltages (such as railroad applications).
- 12) The test voltage of 4000 V<sub>ac(rms)</sub>/50Hz may be applied only once during one minute. It should be noted that with this (strictly speaking obsolete) test method, some (minor) damage occurs to the insulation layers due to the partial discharge. Consequently, this test is not performed at CONCEPT as a series test. In the case of repeated insulation tests (e.g. module test, equipment test, system test), the subsequent tests should be performed with a lower test voltage: the test voltage is reduced by 400V for each additional test. The more modern if more elaborate partial-discharge measurement is better suited than such test methods as it is almost entirely non-destructive.
- 13) The typical blocking time after an error is 1 second. If required, versions with other blocking times may also be supplied.

## Application Hints

### IMPORTANT INFORMATION

This data sheet contains only product-specific data. All data that apply to the whole type series of SCALE drivers are given in the document entitled: “**Description and Application Manual for SCALE Drivers**”. In particular, this manual contains a detailed description of the concept of the SCALE drivers, a description of the function of all terminal pins as well as other important application hints.

Note: As the 1SD1548AI UL is a single-channel driver, the LDI always operates in direct mode.

### Overview and application

The SCALE driver 1SD1548AI UL is a single-channel driver for IGBTs. The 1SD1548AI UL combines compact mechanical dimensions and a simple electrical interface with very high output currents, very high drive power and a special high insulation. This driver can thus be used in almost all conceivable applications, especially for parallel-driving high-power IGBT modules with reverse voltages up to 1700V.

### Output power and self-heating

The specified output power of the driver totals 15W. This typically suffices to drive a 1200A/1200V IGBT module with 40kHz. In the case of a drive power of 15W, the typical input power of the driver is about 18W; the losses due to the driver total about 3W. Because CONCEPT cannot predict how the drivers will be incorporated in the user's application, no binding recommended value for self-heating and thus for the maximum useful output power at high ambient temperatures can be given. It is consequently recommended to check the self-heating of the system, especially when it is used at higher temperatures and if the driver is used with short pulses (on-time or off-time < 1.5  $\mu$ s) continuously.

For calculating the exact output power, reference should be made to Application Note AN-9701 “**I GBT drivers correctly calculated**” on [www.igbt-driver.com/go/app-note](http://www.igbt-driver.com/go/app-note).



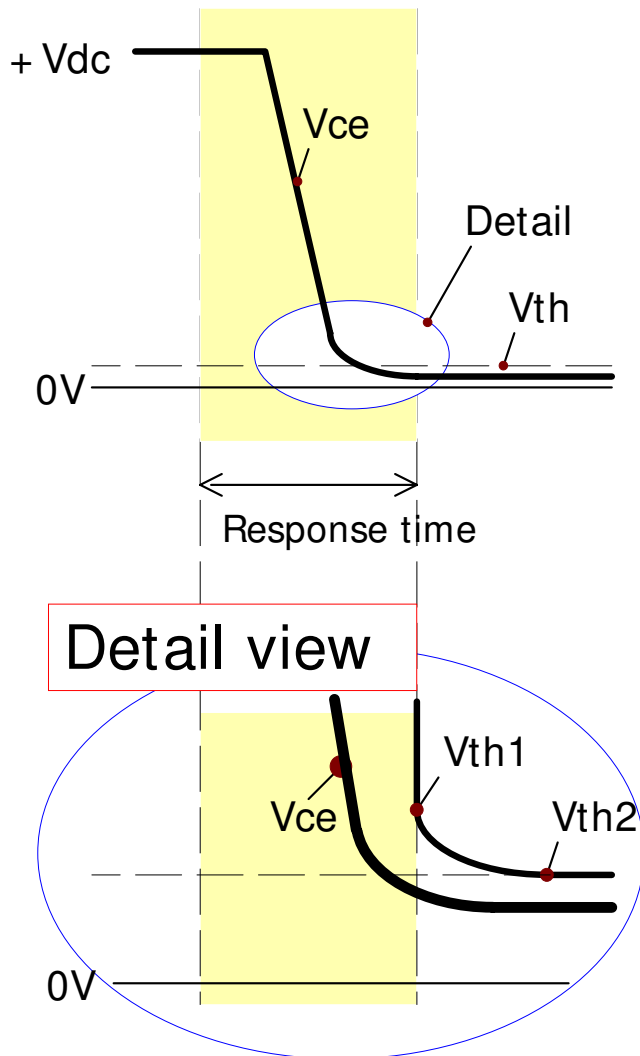

Fig. 5 Collector-sense voltage curve

**Notes on Table 1**

The values for “Vth1” and “Vth2” are listed in Table 1 as a function of the reference resistance Rth.

The value in the “Vth1” column corresponds to the voltage threshold after the response time has elapsed.

The value in the “Vth2” column corresponds to the voltage which is set up statically across the resistor Rth. This static value is typically reached after between 10 and 15 μs.

The value in the  $V_{CE(off)}$  column corresponds to the collector-emitter voltage value at which the protection function is activated when the external circuit is used as shown in Fig. 4 with one or two Dm diodes of type 1N4007 connected in series.

A value of 1n5 is used for the response time capacitor Ca. If this capacitor is rated higher or lower, the response time changes in proportion to the change in capacitance, whereas the thresholds Vth1 and Vth2 remain practically unchanged (they are specified by Rth).

Value Rth	Response time	Vth1	Vth2	$V_{CE(off)}$
22k	≈ 4.9μs	≈ 4.8V	≈ 3.2V	2.35V (1 diode)
27k	≈ 5.7μs	≈ 5.6V	≈ 3.9V	3.05V (1 diode)
33k	≈ 6.8μs	≈ 6.5V	≈ 4.7V	3.25V (2 diodes)
39k	≈ 7.6μs	≈ 7.3V	≈ 5.6V	4.15V (2 diodes)
47k	≈ 9μs	≈ 8.4V	≈ 6.8V	5.35V (2 diodes)

Table 1 Reference resistor, response time and turn-off threshold with  $C_a = 1n5$

---

## Data Sheet

---

### Double or multiple pins

---

Due to the high power and output current and to provide low-inductance interconnections, several pins are present in duplicate or as multiples. It is strictly recommended to connect these in parallel on the layout so that the voltage drop across the lead frames (contact pins) is minimized.

Moreover, input pins 21 and 22 must also be connected to VDC.

---

### Special terminal pins

---

The 1SD1548AI UL driver is optimized for universal use and high driver performance and thus contains more terminal pins than the compact SCALE drivers. These pins will be described below:

---

### VPOS, COM and VNEG pins: external support capacitor

---

Like the compact SCALE drivers, the 1SD1548AI UL also has blocking capacitors on the secondary side of the DC/DC converter. IGBTs with gate charges up to  $12\mu\text{C}$  (corresponding typically to about a 1200V/1200A module) can be driven without external blocking capacitors. At higher gate charges, external blocking capacitors are required between VPOS – COM and COM – VNEG. These capacitors should be rated between 10 and  $42\mu\text{F}$  (but not more than  $84\mu\text{F}$ ) with a dielectric strength of 20V. It is important for the capacitors to be suitable for switched-mode power supply applications (low inductance and high current handling capability). They must be connected as closely as possible to the driver's terminal pins with minimum inductance.

The anode of the capacitor is connected to VPOS (COM), its cathode to COM (VNEG).

---

### VDC and GND pins: supply for DC/ DC converter

---

It is recommended to connect a blocking capacitor of approximately  $220\mu\text{F}$  to the driver input. This capacitor should also be of the switched-mode power supply type.

---

### Pin LS: Local status

---

The status of the IGD 001 is available at this output. It is an open-collector output to which approximately 5mA may be applied. A LED can be connected here, for example, as shown in Fig. 6. The LED lights up in normal operation (everything OK) and goes out when the driver detects an undervoltage or during the blocking time.

---

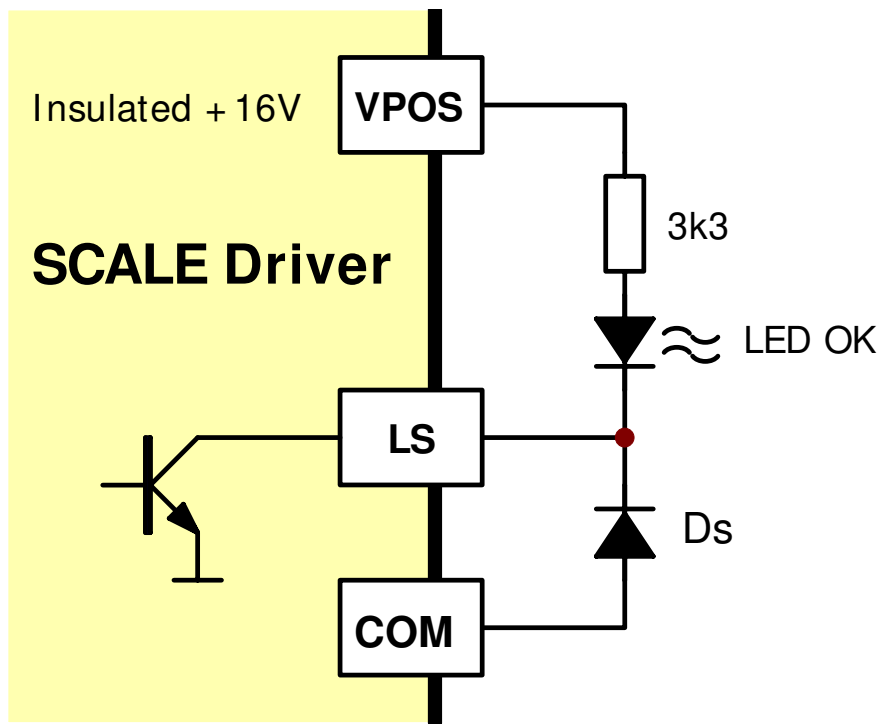

Fig. 6 Status display with LED at pin LS

**Caution:**

The Schottky diode Ds should not be omitted if the local status output is used. If the local status output is not used, LS should be connected to COM in order to increase the noise immunity of the driver.

**Pin AC: Enhanced active clamping**

Pin AC allows the basic active clamping function of the driver to be improved (see Fig. 1). If it is not used, it should be connected to VNEG.

As the appropriate dimensioning of improved active clamping is complex, time-consuming and not necessary for most applications, CONCEPT does not support this feature. However, if this function should be required, or for more information, please contact CONCEPT's technical support.

**Configuration within the power section**

The drivers should be located as closely as possible to the power transistors. The connecting leads to the transistors should be as short as possible and as low inductance as possible, i.e. they can be up to 3 cm to 10 cm long depending on the gate current and switching speed.

## Data Sheet

**If you need any help, simply call our technical support**

CONCEPT provides expert help with your questions and problems:

[www.IGBT-Driver.com/go/support](http://www.IGBT-Driver.com/go/support)

**Quite Special: Customized SCALE Drivers**

If you need an IGBT driver that is not included in the delivery range, please don't hesitate to contact CONCEPT or your CONCEPT sales partner.

CONCEPT engineers have more than 20 years experience in the development and manufacture of intelligent gate drivers for power MOSFETs and IGBTs and have already implemented a large number of customized solutions.

**Important Notice**

The data contained in this product data sheet is intended exclusively for technically trained staff. Handling all high-voltage equipment involves risk to life. Strict compliance with the respective safety regulations is mandatory!

Any handling of electronic devices is subject to the general specifications for protecting electrostatic-sensitive devices according to international standard IEC 747-1, Chapter IX or European standard EN 100015 (i.e. the workplace, tools, etc. must comply with these standards). Otherwise, this product may be damaged.

**Legal Disclaimer**

This data sheet specifies devices but cannot promise to deliver any specific characteristics. No warranty or guarantee is given – either expressly or implicitly – regarding delivery, performance or suitability.

CT-Concept Technologie AG reserves the right to make modifications to its technical data and product specifications at any time without prior notice. The general terms and conditions of delivery of CT-Concept Technologie AG apply.

## Ordering Information

The general terms and conditions of delivery of CT-Concept Technologie AG apply.

Type designation	Description
1SD1548AI UL	UL Compliant Single-Channel SCALE Driver Core

## Information about Other Products

**For other drivers, product documentation, and application support**

Direct link: Please click: [www.IGBT-Driver.com](http://www.IGBT-Driver.com)

## Manufacturer

CT-Concept Technologie AG  
Intelligent Power Electronics  
Renferstrasse 15  
CH-2504 Biel-Bienne  
Switzerland

Tel. + 41 - 32 - 344 47 47  
Fax + 41 - 32 - 344 47 40

E-mail [Info@IGBT-Driver.com](mailto:Info@IGBT-Driver.com)  
Internet [www.IGBT-Driver.com](http://www.IGBT-Driver.com)

© Copyright 2003...2009 by CT-Concept Technologie AG - Switzerland.

All rights reserved.

We reserve the right to make any technical modifications without prior notice. Version from 2009-09-15