



Chipsmall Limited consists of a professional team with an average of over 10 year of expertise in the distribution of electronic components. Based in Hongkong, we have already established firm and mutual-benefit business relationships with customers from,Europe,America and south Asia,supplying obsolete and hard-to-find components to meet their specific needs.

With the principle of “Quality Parts,Customers Priority,Honest Operation,and Considerate Service”,our business mainly focus on the distribution of electronic components. Line cards we deal with include Microchip,ALPS,ROHM,Xilinx,Pulse,ON,Everlight and Freescale. Main products comprise IC,Modules,Potentiometer,IC Socket,Relay,Connector.Our parts cover such applications as commercial,industrial, and automotives areas.

We are looking forward to setting up business relationship with you and hope to provide you with the best service and solution. Let us make a better world for our industry!



Contact us

Tel: +86-755-8981 8866 Fax: +86-755-8427 6832

Email & Skype: info@chipsmall.com Web: www.chipsmall.com

Address: A1208, Overseas Decoration Building, #122 Zhenhua RD., Futian, Shenzhen, China



LOC		DIST		REVISIONS				
P	LTR	DESCRIPTION	DATE	DNW	APVD			
AD	00	SEE SHEET 1						

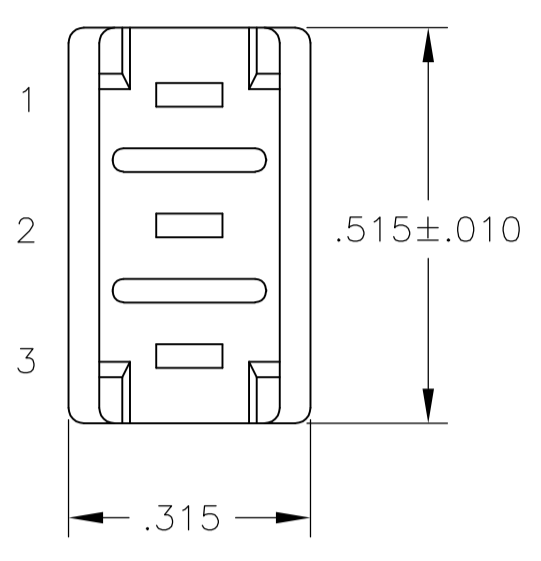
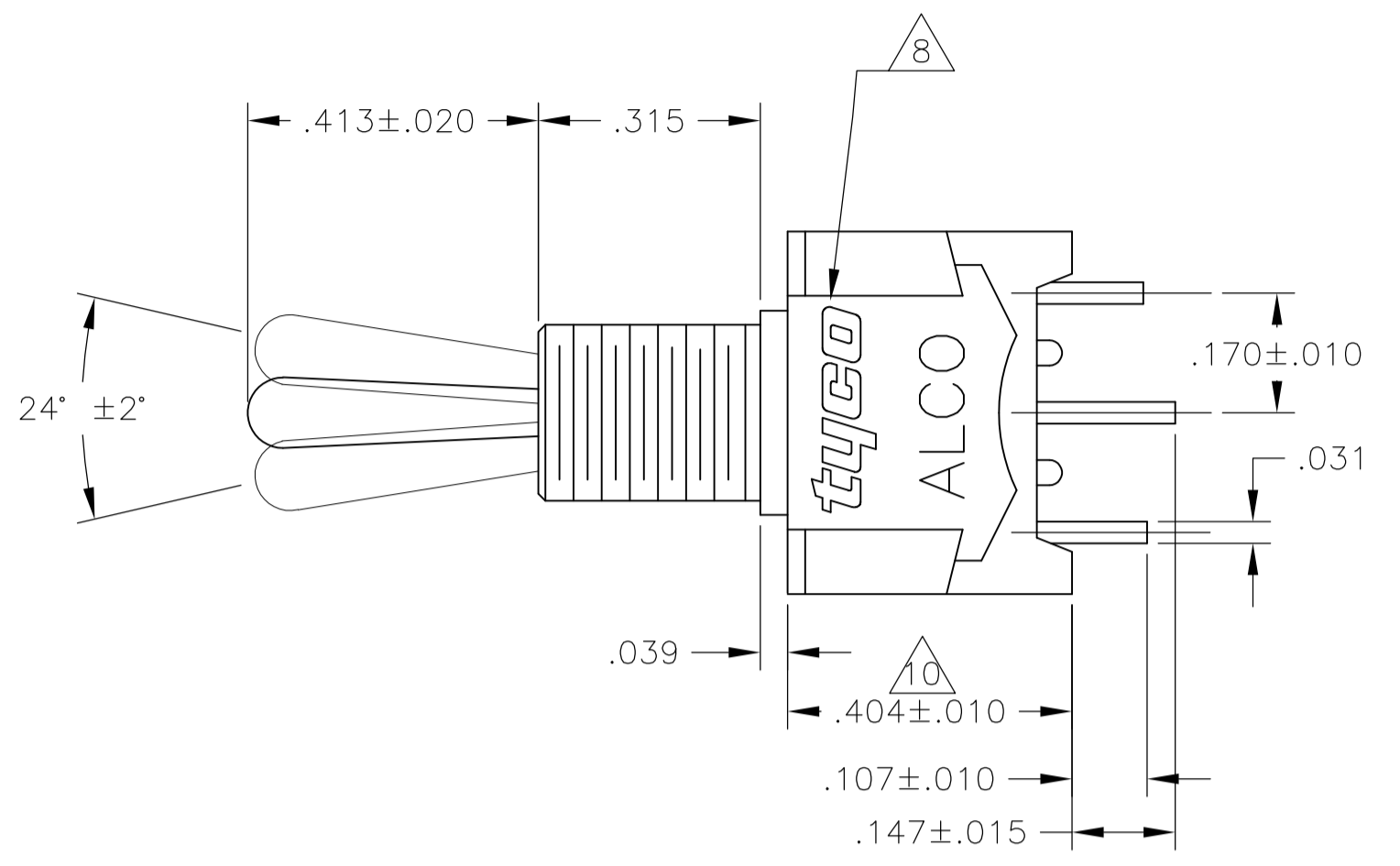

MTA106

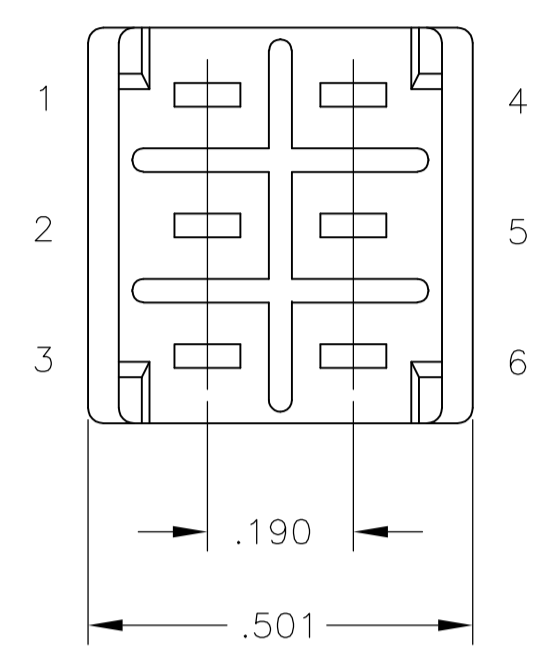

MTA206

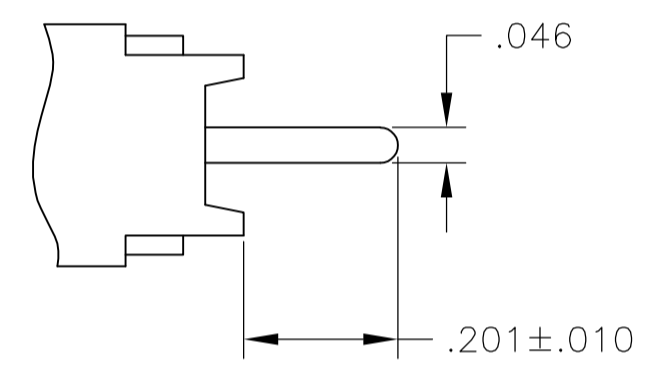
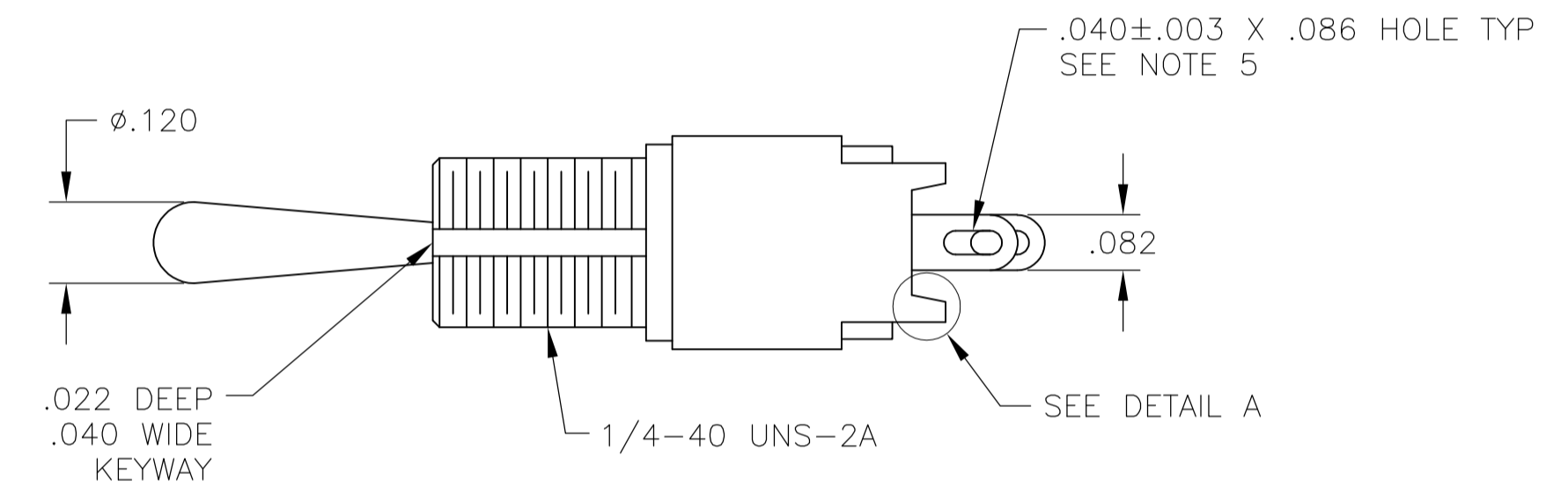

PC TERMINAL

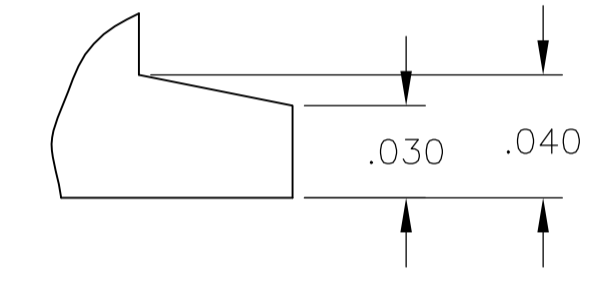

DETAIL A
SCALE 16:1

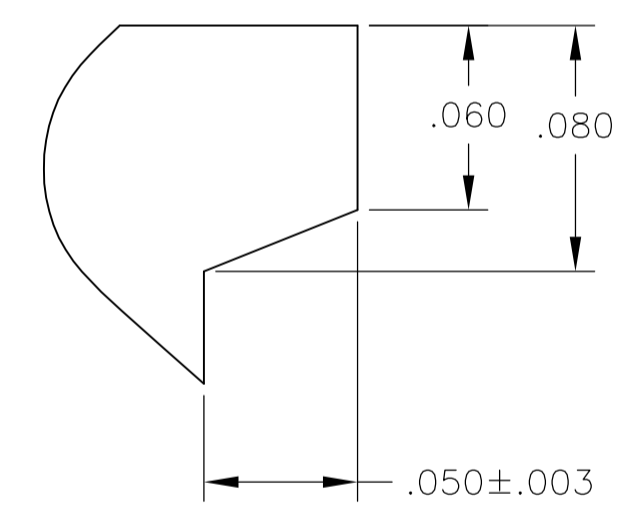
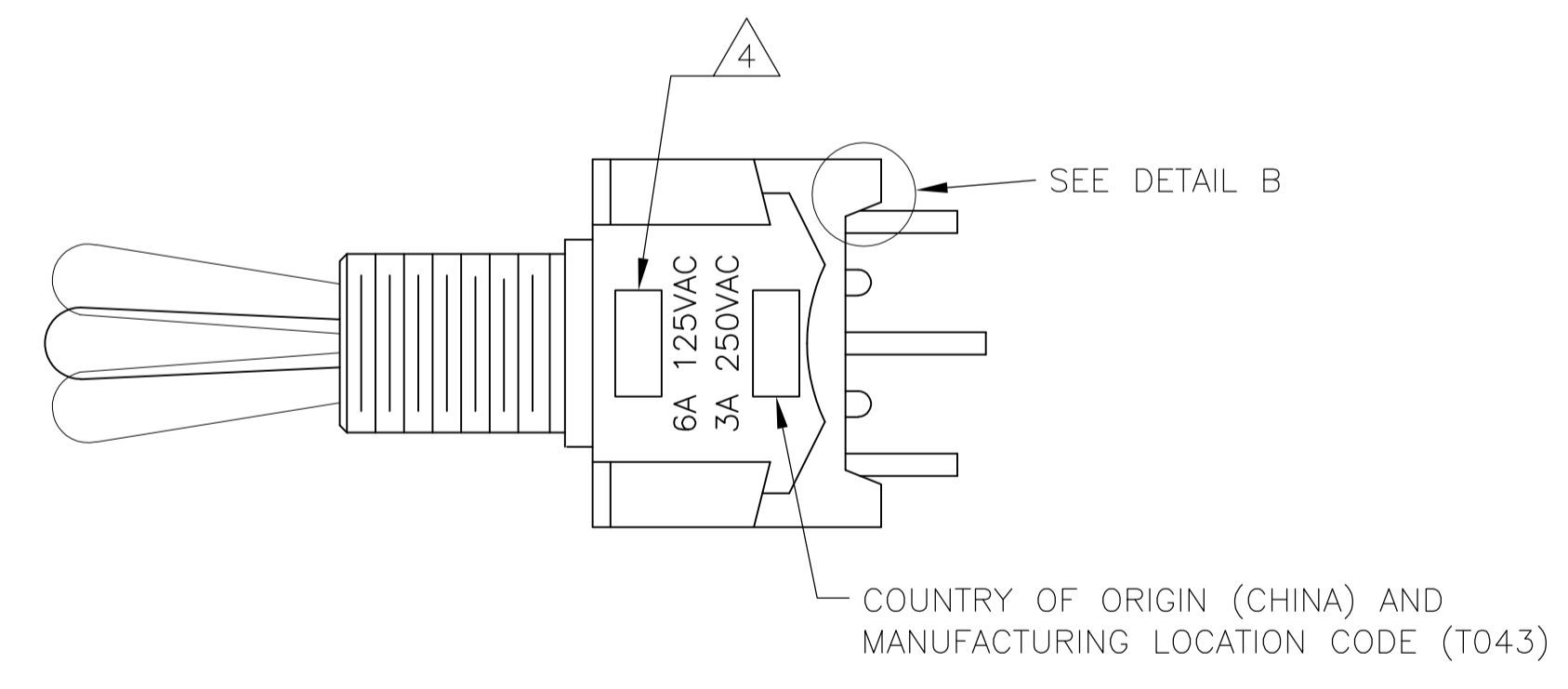

DETAIL B
SCALE 16:1

WIRE LUG TERMINAL

THIS DRAWING IS A CONTROLLED DOCUMENT.		DIN BSV 02DEC2005	TE Connectivity	
DIMENSIONS: INCHES		CIK -		
TOLERANCES UNLESS OTHERWISE SPECIFIED:		APVD M. ZITTO 29DEC03	NAME ALCOSWITCH GREEN SERIES TOGGLE SWITCH MTA VERTICAL MOUNT	
0 PLC ± -		PRODUCT SPEC	APPLICATION SPEC	
1 PLC ± -		SIZE A1	CAGE CODE 00779	DRAWING NO. 1571920
2 PLC ± -		WEIGHT	RESTRICTED TO	
3 PLC ± .005		CUSTOMER DRAWING	SCALE 4:1	SHEET 2 OF 3
4 PLC ± -				REV A3
ANGLES ± 1				
MATERIAL -				
FINISH -				

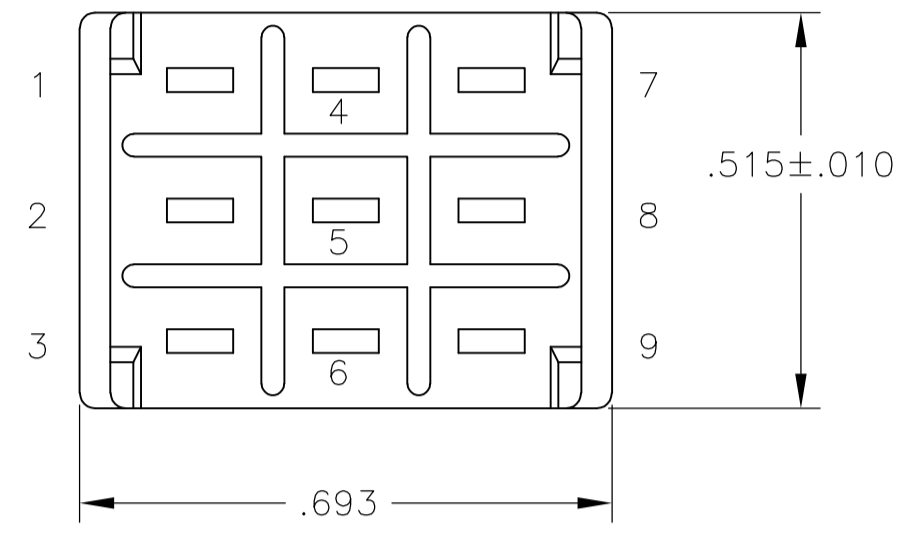
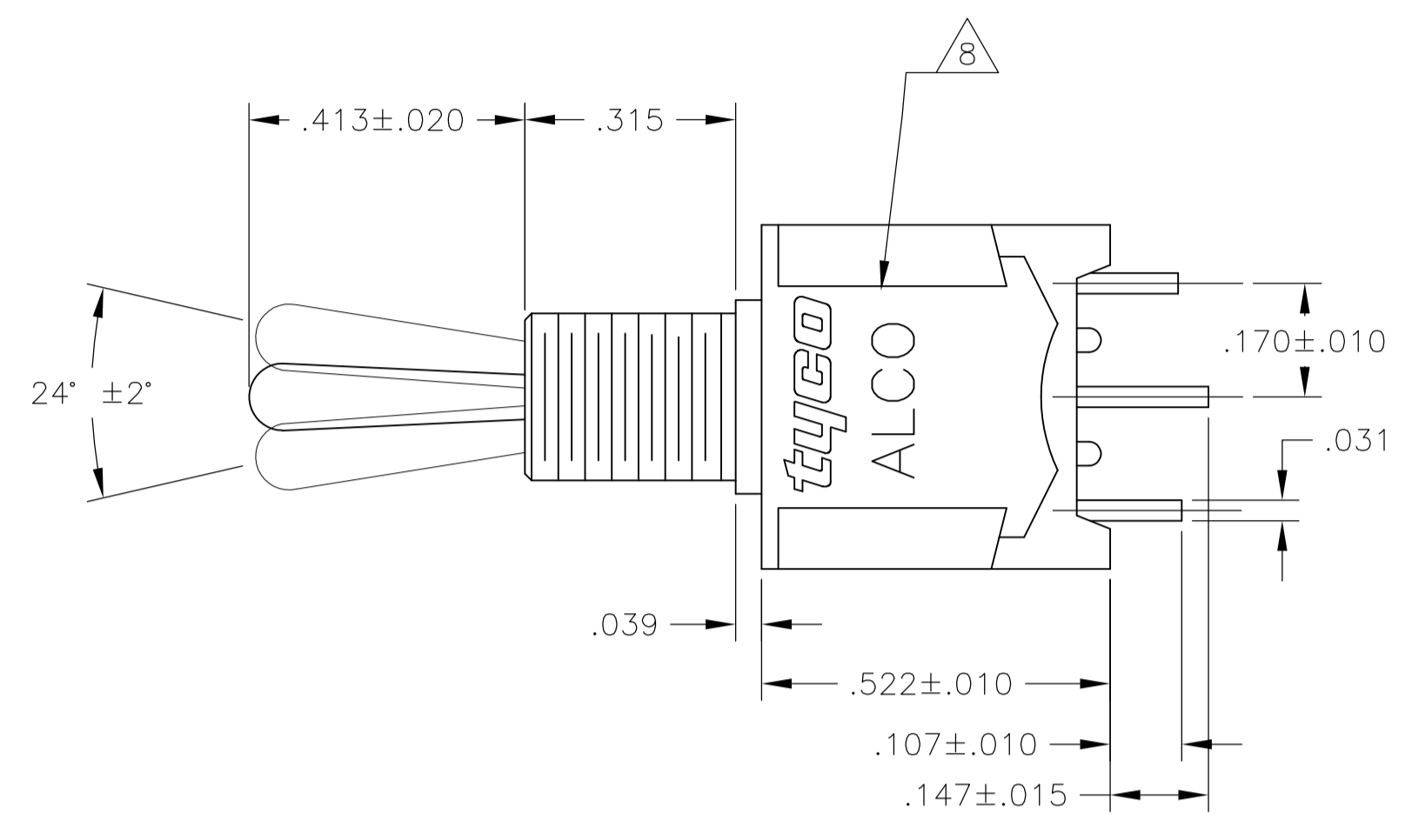

MTA306

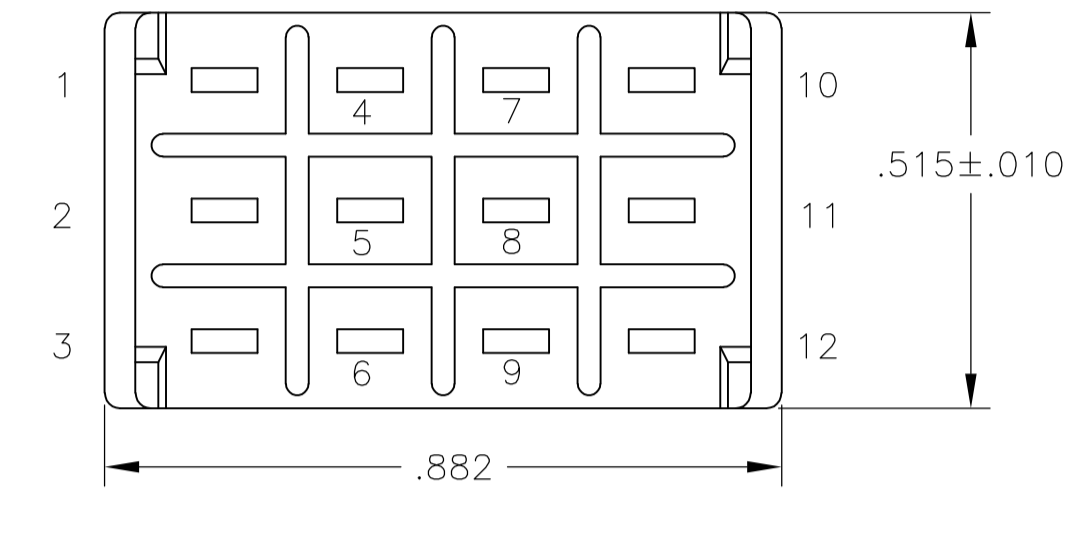

MTA406

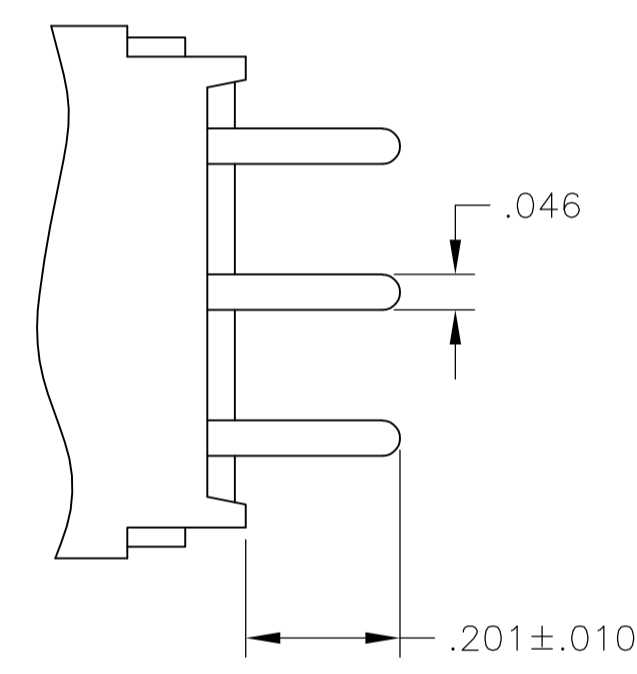
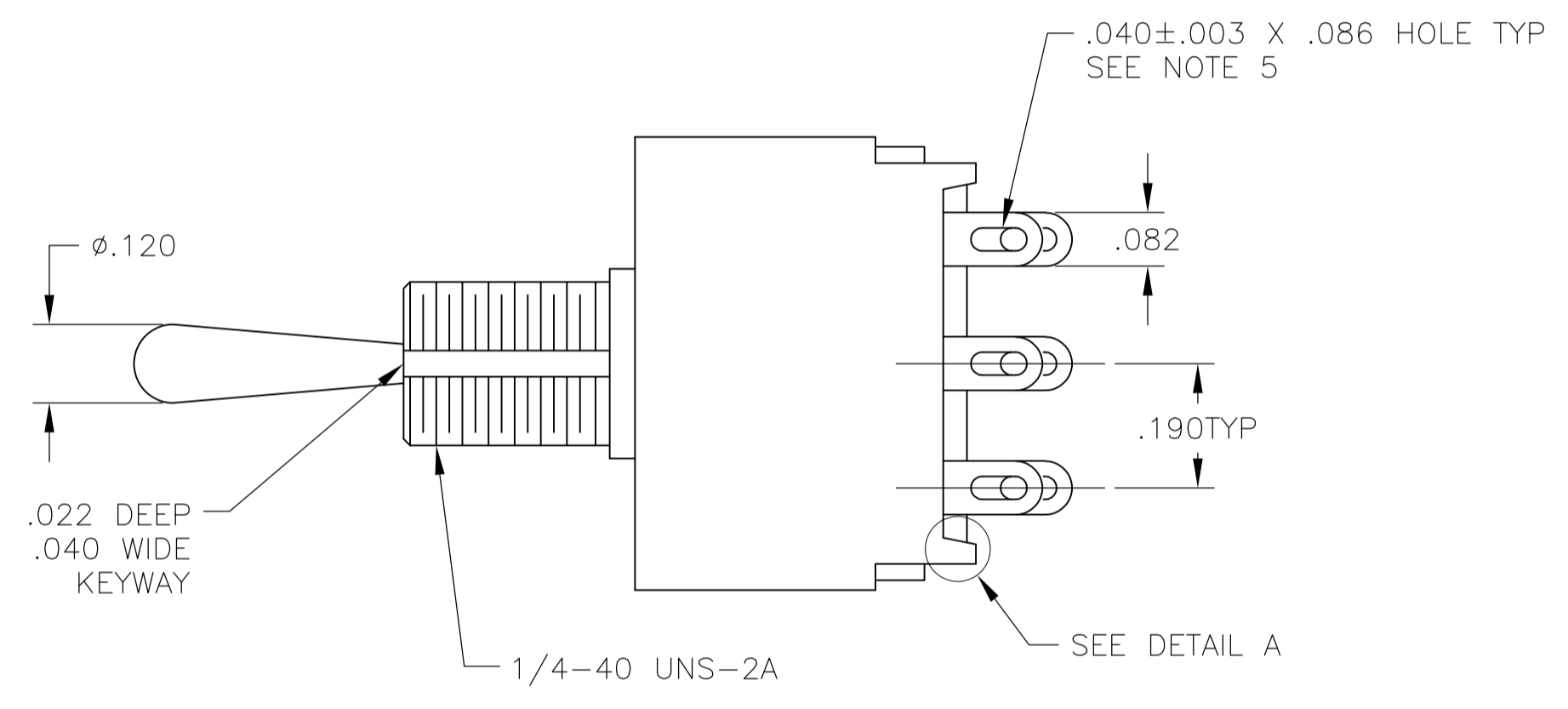

PC TERMINAL

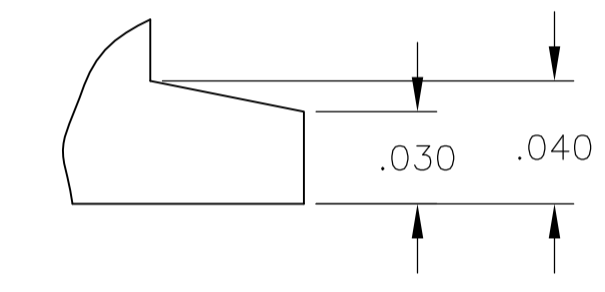

DETAIL A
SCALE 16:1

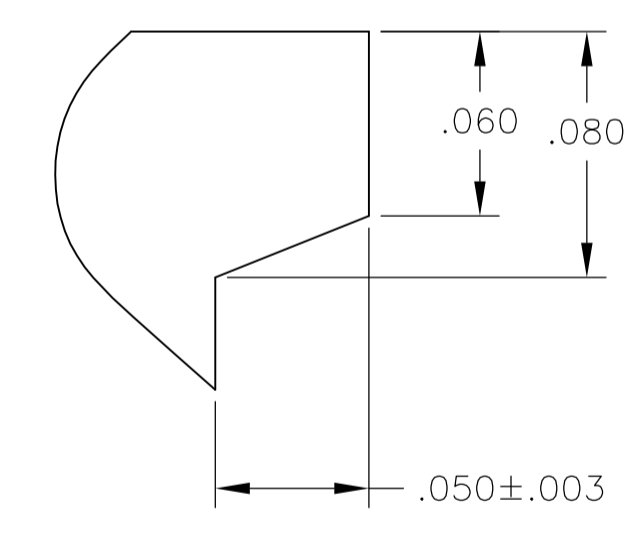

DETAIL B
SCALE 16:1

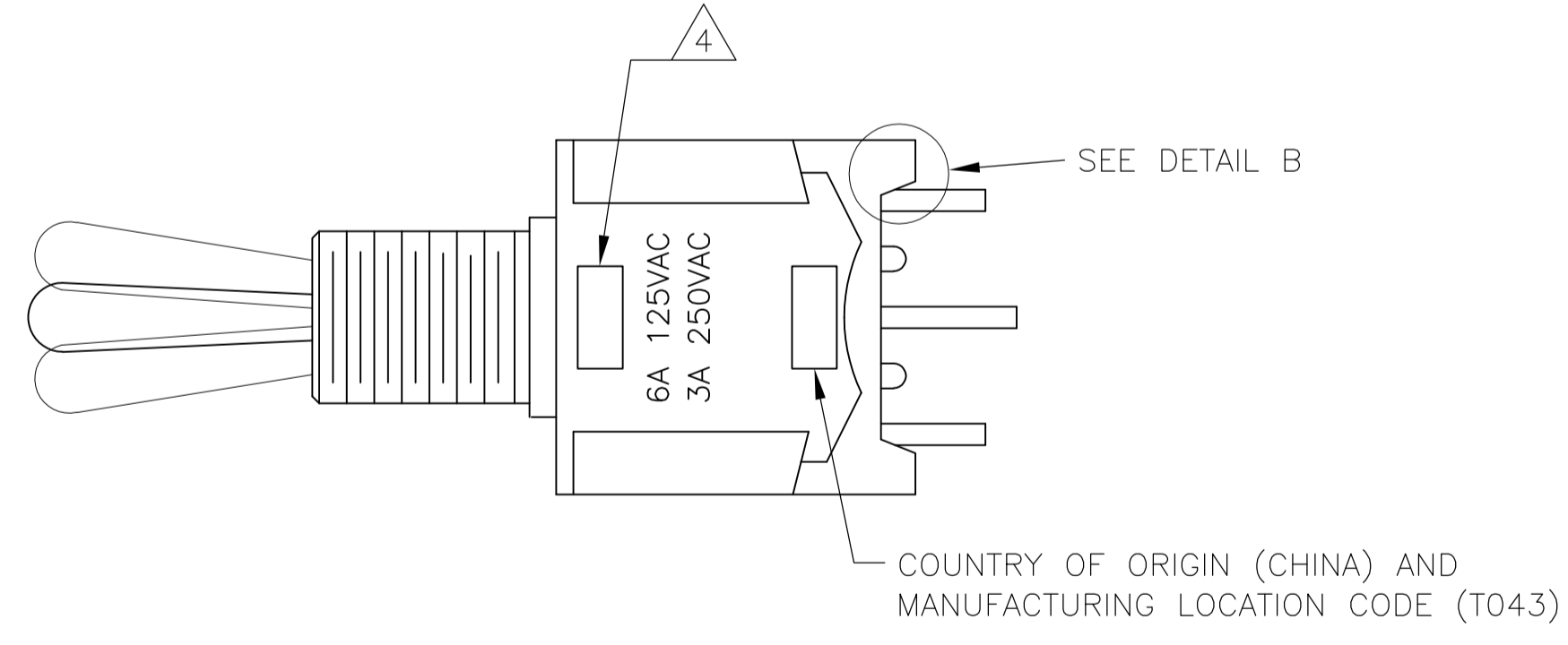

WIRE LUG TERMINAL

THIS DRAWING IS A CONTROLLED DOCUMENT.		DWG: BSV 02DEC2005		
DIMENSIONS: INCHES		CHK: -		
TOLERANCES UNLESS OTHERWISE SPECIFIED:		APVD: M. ZITTO 29DEC03	NAME: ALCOSWITCH GREEN SERIES TOGGLE SWITCH MTA VERTICAL MOUNT	
0 PLC ± - 1 PLC ± - 2 PLC ± - 3 PLC ± .005 4 PLC ± - ANGLES ± # 1		PRODUCT SPEC: -	RESTRICTED TO: -	
MATERIAL: -		FINISH: -	APPLICATION SPEC: -	SIZE: A1
CUSTOMER DRAWING		WEIGHT: -	SCALE: 4:1	SHEET 3 OF 3
		DRAWING NO: 1571920	REV: A3	