



Chipsmall Limited consists of a professional team with an average of over 10 year of expertise in the distribution of electronic components. Based in Hongkong, we have already established firm and mutual-benefit business relationships with customers from,Europe,America and south Asia,supplying obsolete and hard-to-find components to meet their specific needs.

With the principle of “Quality Parts,Customers Priority,Honest Operation,and Considerate Service”,our business mainly focus on the distribution of electronic components. Line cards we deal with include Microchip,ALPS,ROHM,Xilinx,Pulse,ON,Everlight and Freescale. Main products comprise IC,Modules,Potentiometer,IC Socket,Relay,Connector.Our parts cover such applications as commercial,industrial, and automotives areas.

We are looking forward to setting up business relationship with you and hope to provide you with the best service and solution. Let us make a better world for our industry!



Contact us

Tel: +86-755-8981 8866 Fax: +86-755-8427 6832

Email & Skype: info@chipsmall.com Web: www.chipsmall.com

Address: A1208, Overseas Decoration Building, #122 Zhenhua RD., Futian, Shenzhen, China



THIS DRAWING IS UNPUBLISHED. RELEASED FOR PUBLICATION
 © COPYRIGHT - By - ALL RIGHTS RESERVED.

LOC		DIST		REVISIONS			
P	LTR	DESCRIPTION		DATE	DWN	APVD	
AF	50	B1	REVISED PER ECR-13-000608		17JAN13	KH	GJ

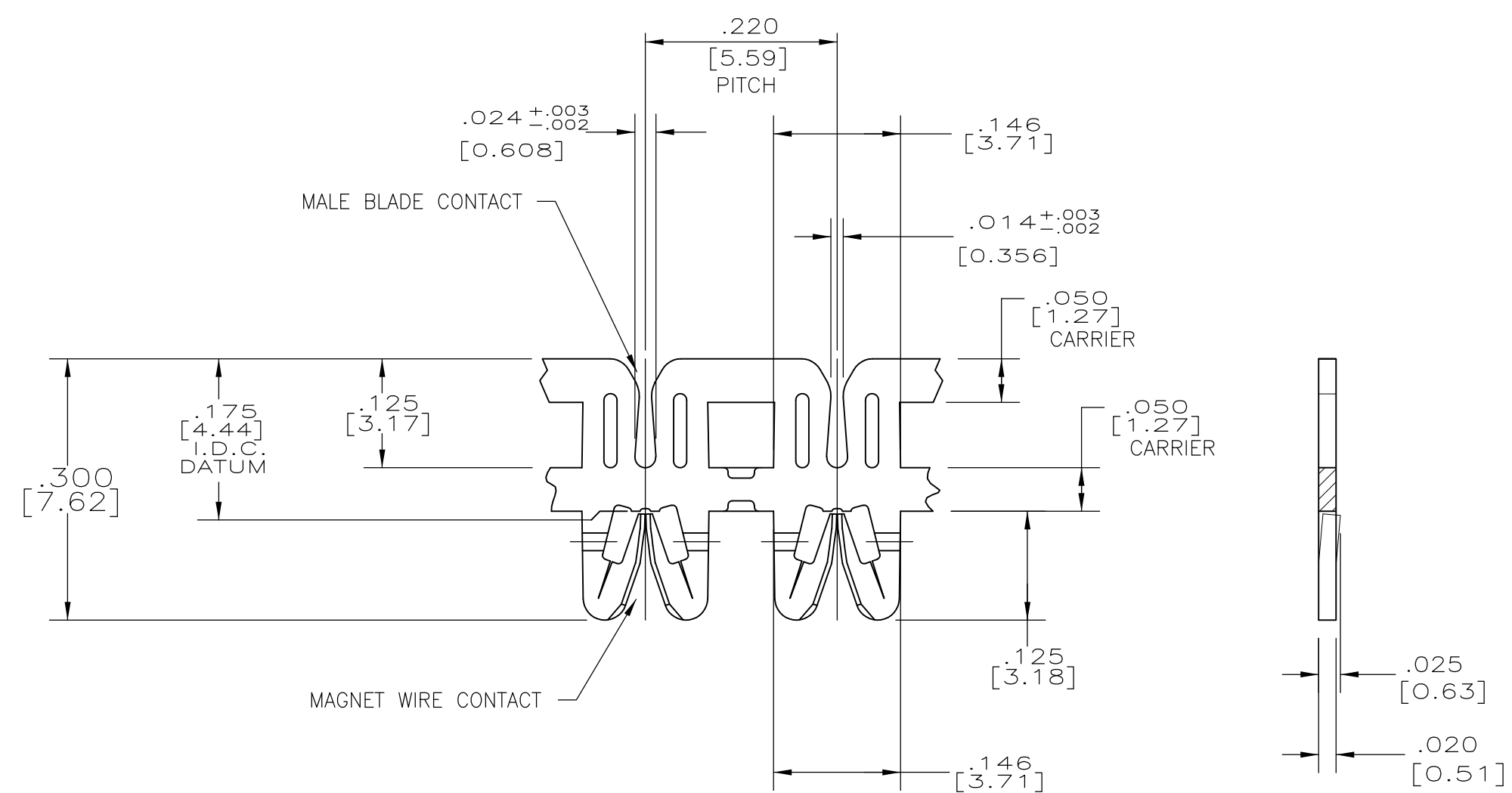

- SPECIFICATIONS:
MAGNET WIRE #18 - #34 AWG, .006"(0.16MM)-.040"(1.02MM) DIA COPPER. OTHER SIZES MAY BE ACCOMMODATED, CONSULT TYCO ELECTRONICS FOR APPROVAL. MALE BLADE .020" (0.5mm) THICK BRASS
- POCKET RECOMMENDATION: #1601426
- TERMINAL APPLICATION TO COMPLY WITH TYCO ELECTRONICS SPECIFICATION 114-13166 FIGURE 11.
- PRELIMINARY - NOT FOR PRODUCTION
- TWO (2) TERMINALS SHOWN FOR ILLUSTRATION PURPOSES ONLY.
- PRE-PRODUCTION - FASR REQUIRED.

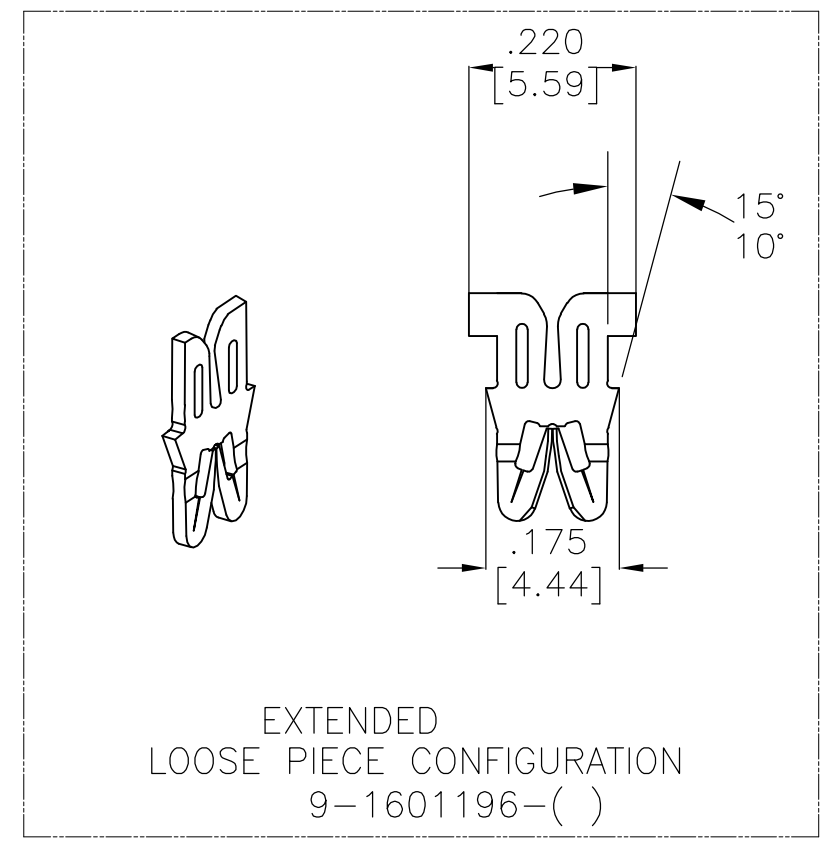
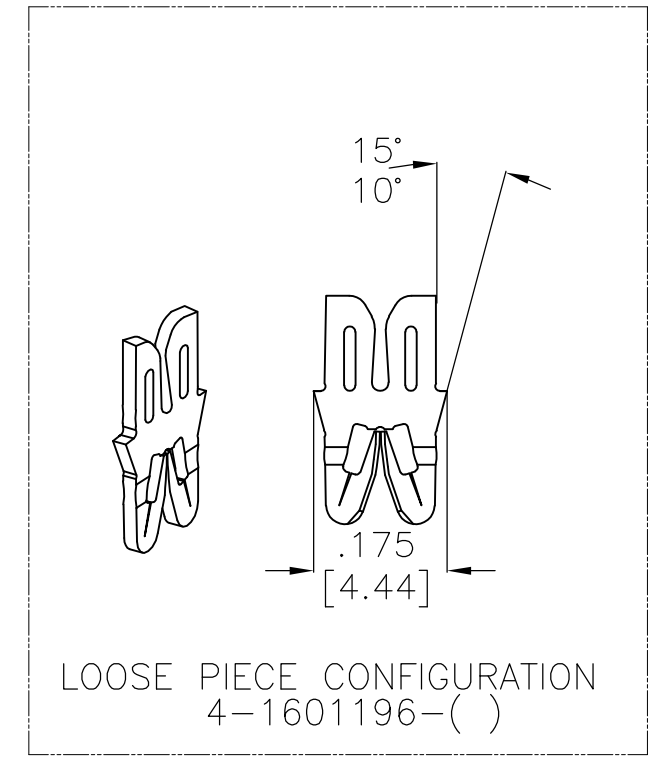
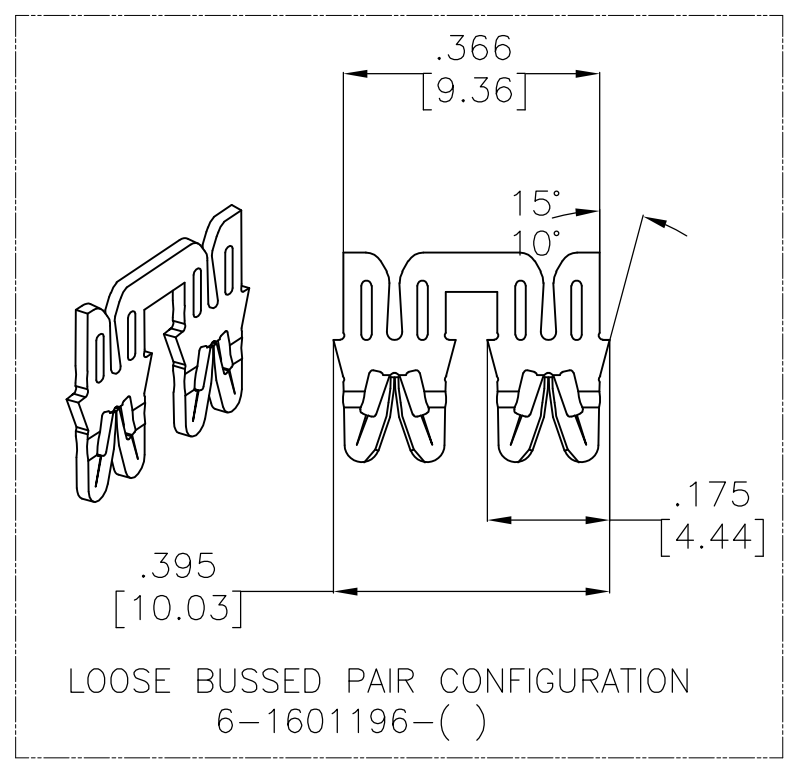
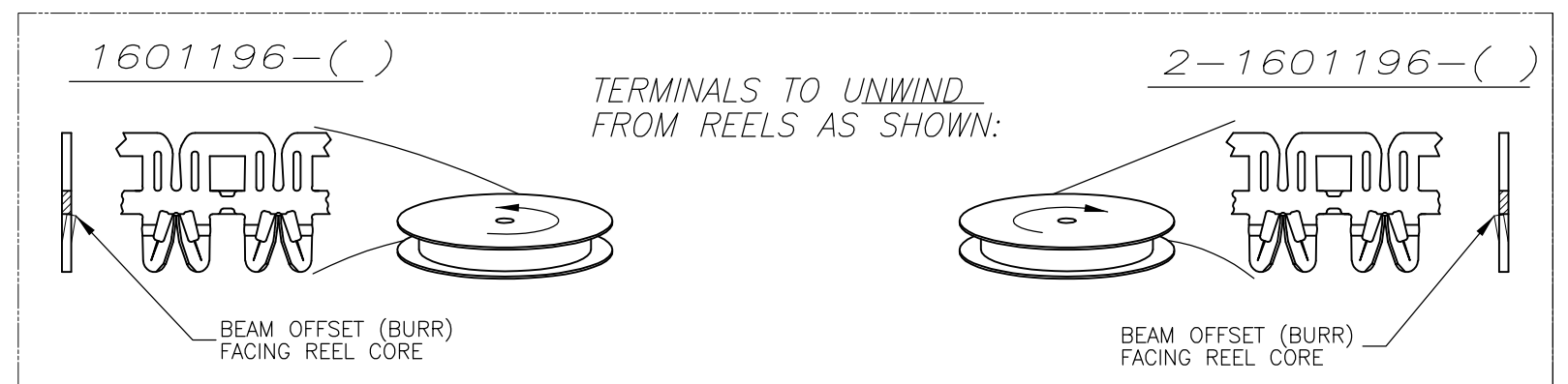
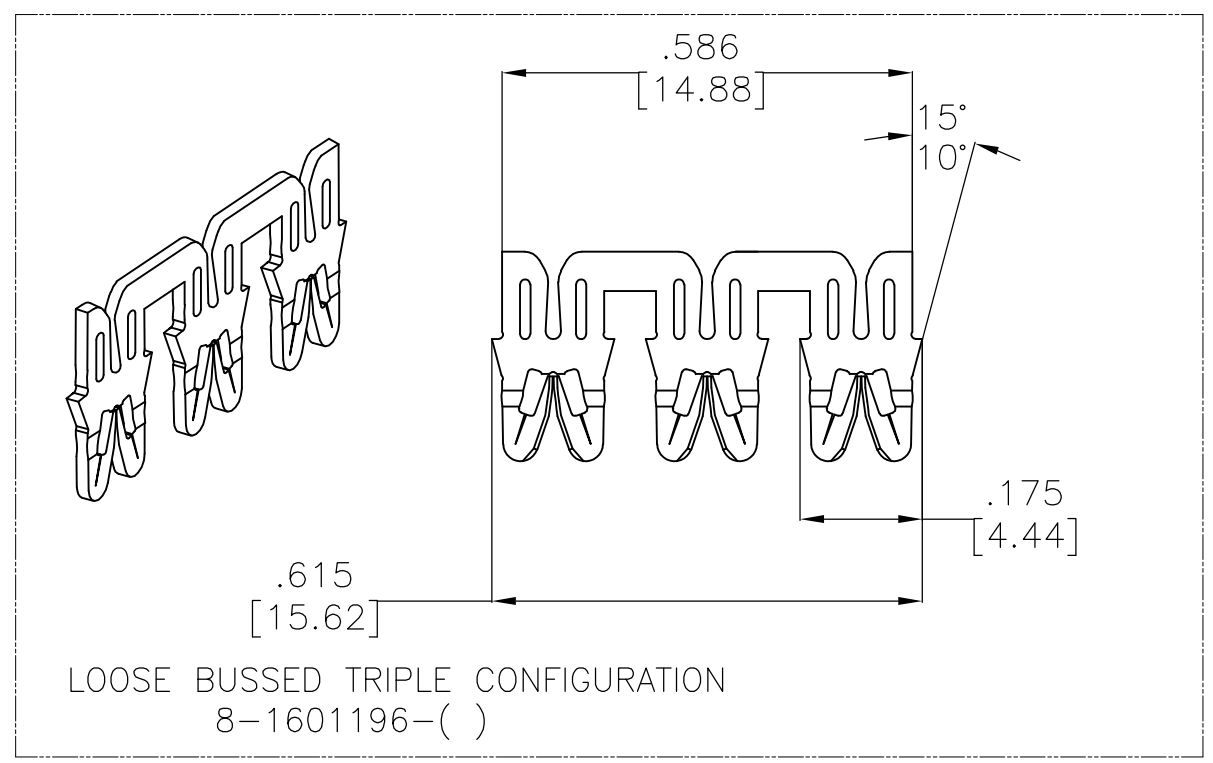

UNPLATED	4	9-1601196-1
UNPLATED	4	8-1601196-1
UNPLATED	4	6-1601196-1
UNPLATED		2-1601196-1
POST TIN OVER NICKEL	6	1601196-2
UNPLATED		1601196-1
FINISH		PART NUMBER

THIS DRAWING IS A CONTROLLED DOCUMENT.		DWN MICHAEL S. FEHER 25MAY2004		
DIMENSIONS: mm [INCHES]		CHK GENE JACONO 25MAY2004		
TOLERANCES UNLESS OTHERWISE SPECIFIED:		APVD GENE JACONO 25MAY2004	NAME	
0 PLC ± -		PRODUCT SPEC	STANDARD RANGE HIGH CARRIER	
1 PLC ± -		108-2085	WIRE TO BLADE SIAMEZE TERMINAL	
2 PLC ± .01[0.25]		APPLICATION SPEC	-	
3 PLC ± .005[0.13]		3	SIZE	CAGE CODE
4 PLC ± - 2'			A2	00779
MATERIAL BRASS, SPRING HARD		FINISH SEE TABLE	DRAWING NO	RESTRICTED TO
		WEIGHT	C=1601196	-
		CUSTOMER DRAWING	SCALE	SHEET
			1:1	1 OF 1
			REV	B1