



Chipsmall Limited consists of a professional team with an average of over 10 year of expertise in the distribution of electronic components. Based in Hongkong, we have already established firm and mutual-benefit business relationships with customers from,Europe,America and south Asia,supplying obsolete and hard-to-find components to meet their specific needs.

With the principle of "Quality Parts,Customers Priority,Honest Operation,and Considerate Service",our business mainly focus on the distribution of electronic components. Line cards we deal with include Microchip,ALPS,ROHM,Xilinx,Pulse,ON,Everlight and Freescale. Main products comprise IC,Modules,Potentiometer,IC Socket,Relay,Connector.Our parts cover such applications as commercial,industrial, and automotives areas.

We are looking forward to setting up business relationship with you and hope to provide you with the best service and solution. Let us make a better world for our industry!



## Contact us

Tel: +86-755-8981 8866 Fax: +86-755-8427 6832

Email & Skype: info@chipsmall.com Web: www.chipsmall.com

Address: A1208, Overseas Decoration Building, #122 Zhenhua RD., Futian, Shenzhen, China



THIS DRAWING IS UNPUBLISHED. RELEASED FOR PUBLICATION  
 © COPYRIGHT BY TYCO ELECTRONICS CORPORATION. ALL RIGHTS RESERVED.

LOC		DIST		REVISIONS			
P	LTR	DESCRIPTION		DATE	DWN	APVD	
	F1	REVISED PER ECO-10-000443		18JAN10	KK	HMR	

1. SPECIFICATIONS:

TAB BLADE 2mm x 0.8mm  
 OTHER SIZES MAY BE ACCOMMODATED,  
 CONSULT TYCO ELECTRONICS  
 FOR APPROVAL.

2. POCKET RECOMMENDATION: 1601441.

3. TERMINAL SUPPLIED ON REELS,  
 CAN BE SUPPLIED LOOSE PIECE,

- 4. PRE-TIN PLATE OVER COPPER UNDERPLATE.
- 5. POST-TIN PLATE OVER NICKEL UNDERPLATE.
- 6. CARRIER STRIP THICKNESS OVER THREE TERMINALS  
 INCLUSIVE NOT TO EXCEED .024 [0.61] MAX

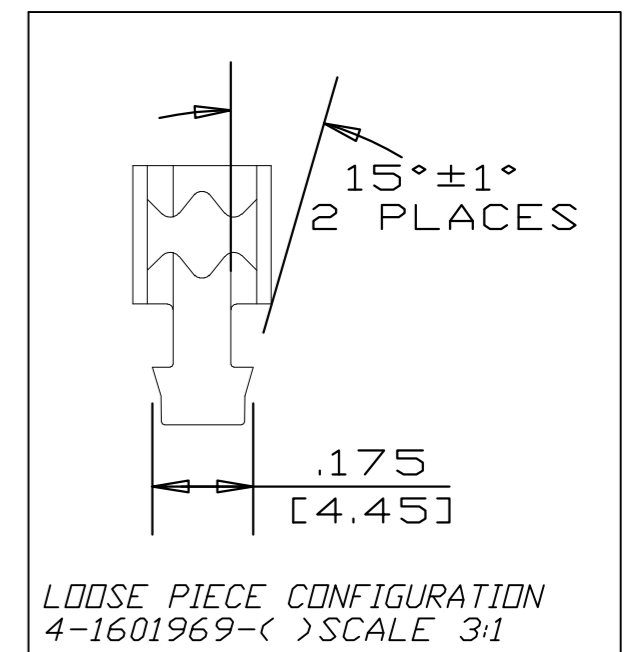
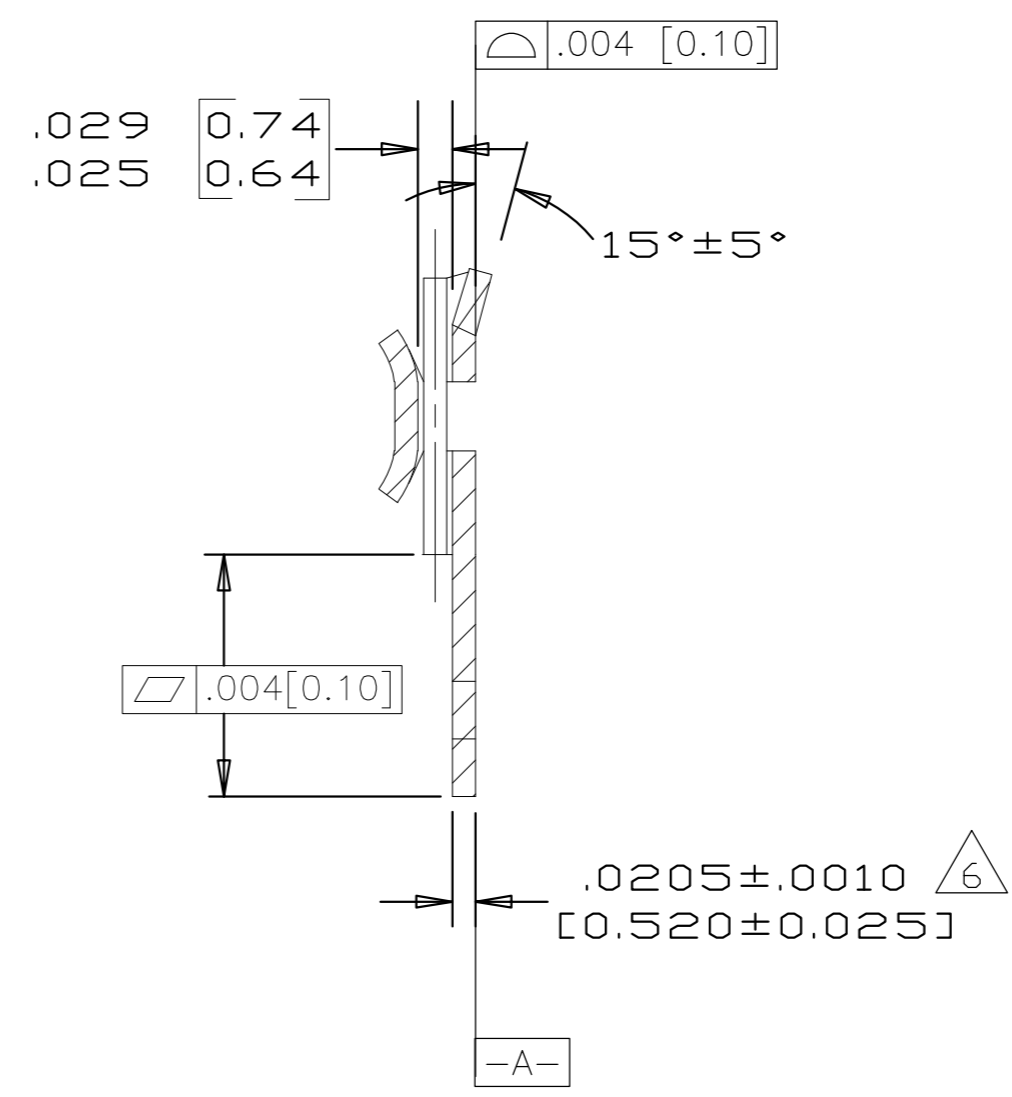
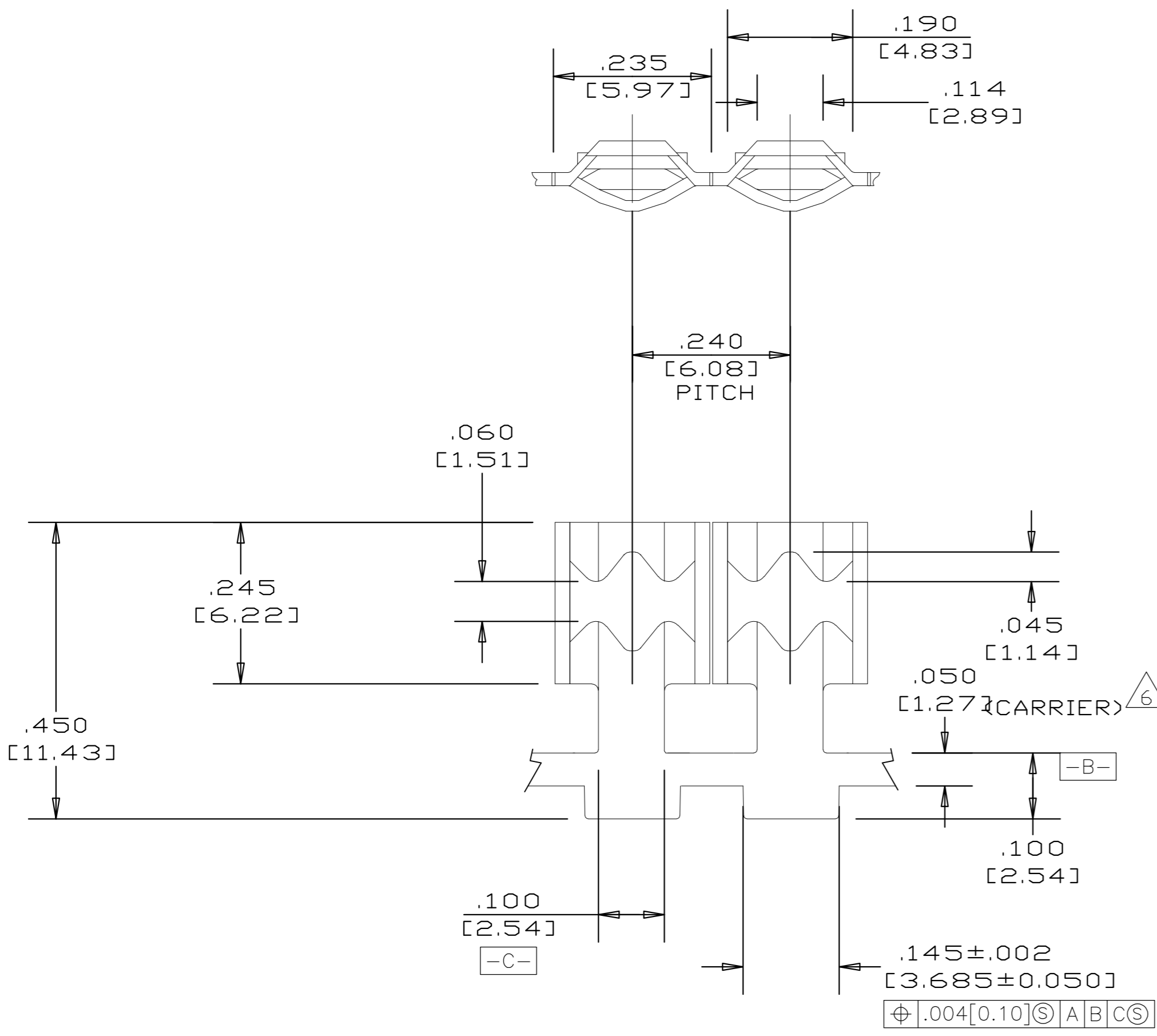

7. OBSOLETE PARTS: OBSOLETE CIS STREAMLINING  
 PER D.RENAUD/D.SINISI

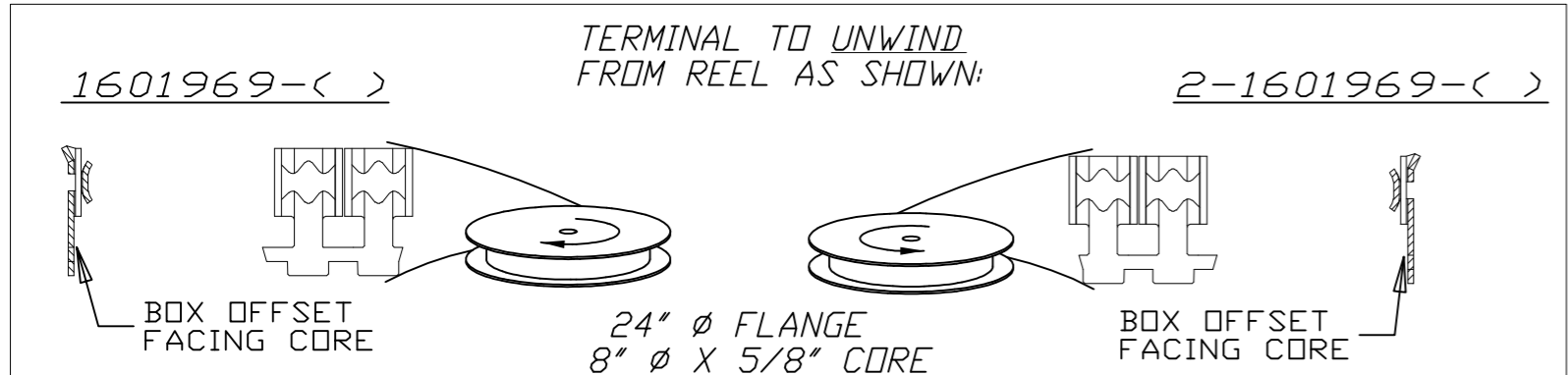

MATERIAL	FINISH	FINISH	FINISH	REFERENCE PART NUMBER	TYCO PART NUMBER
H03 BRASS	N/A	4	4	016-011-014	4-1601969-2
H02 PHOSPHOR BRONZE	MASONITE	4	5	N/A	2-1601969-3
H03 BRASS	CARDBOARD	4	4	116-012-014	2-1601969-2
H03 BRASS	CARDBOARD	4	4	116-011-014	1601969-2

THIS DRAWING IS A CONTROLLED DOCUMENT.		DWN 28MAR2002 MICHAEL S. FEHER	Tyco Electronics Corporation Harrisburg, Pa 17105-3608	
DIMENSIONS: INCHES		CHK 28MAR2002 GENE JACONO	NAME: 2.0mm X 0.8mm BLADE RECEPTACLE TERMINAL	
TOLERANCES UNLESS OTHERWISE SPECIFIED: 0 PLC ± - 1 PLC ± - 2 PLC ± .01[0.25] 3 PLC ± .005[0.13] 4 PLC ± - ANGLES ± 2°		APVD 28MAR2002 GENE JACONO	SIZE: A2 CAGE CODE: 00779 DRAWING NO: 1601969 RESTRICTED TO: -	
MATERIAL: SEE TABLE	FINISH: SEE TABLE	WEIGHT: -	SCALE: 6:1	SHEET 1 OF 1 REV F1