



Chipsmall Limited consists of a professional team with an average of over 10 year of expertise in the distribution of electronic components. Based in Hongkong, we have already established firm and mutual-benefit business relationships with customers from,Europe,America and south Asia,supplying obsolete and hard-to-find components to meet their specific needs.

With the principle of “Quality Parts,Customers Priority,Honest Operation,and Considerate Service”,our business mainly focus on the distribution of electronic components. Line cards we deal with include Microchip,ALPS,ROHM,Xilinx,Pulse,ON,Everlight and Freescale. Main products comprise IC,Modules,Potentiometer,IC Socket,Relay,Connector.Our parts cover such applications as commercial,industrial, and automotives areas.

We are looking forward to setting up business relationship with you and hope to provide you with the best service and solution. Let us make a better world for our industry!



Contact us

Tel: +86-755-8981 8866 Fax: +86-755-8427 6832

Email & Skype: info@chipsmall.com Web: www.chipsmall.com

Address: A1208, Overseas Decoration Building, #122 Zhenhua RD., Futian, Shenzhen, China



ECN #	APPRVD.	DATE
08-023523	IEC	26DEC08

SAFETY ORGANIZATIONS

THIS FILTER HAS BEEN FORMALLY RECOGNIZED, CERTIFIED OR APPROVED BY THE LISTED AGENCY. THEREFORE, ALL TEST/REQUIREMENTS SPECIFIED IN THE LATEST REVISION OF THE FOLLOWING AGENCY STANDARDS HAVE BEEN MET:

UL RECOGNIZED: UL 1283
 CSA CERTIFIED: CSA C22.2, # 8
 VDE APPROVED: EN 60939-2

OPERATING SPECIFICATIONS

LINE CURRENT/VOLTAGE: 15 AMP @ 120 VAC, 10 AMP @ 250 VAC (UL & CSA)
 10 AMP/40°C @ 250 VAC (VDE)

LINE FREQUENCY: 50-60Hz

MAXIMUM LEAKAGE CURRENT,
 EACH LINE TO GROUND: 0.25 mA @ 120V 60Hz
 0.40 mA @ 250V 50Hz

OPERATING AMBIENT TEMP. RANGE: -10°C TO +40°C @ RATED CURRENT, I_r.

IN AN AMBIENT, T₀, HIGHER THAN 40°C, THE MAXIMUM OPERATING CURRENT, I₀, IS AS FOLLOWS:

$$I_0 = I_r \sqrt{\frac{85 - T_0}{45}}$$

RELIABILITY SPECIFICATIONS:

STORAGE TEMPERATURE: -40°C TO +85°C
 HUMIDITY: 21 DAYS @ 40°C 95% RH.
 CURRENT OVERLOAD TEST: 6 TIMES I_r FOR 8 SECONDS

TEST SPECIFICATIONS:

INDUCTANCE: 0.11 mH NOMINAL
 CAPACITANCE: (MEASURED @ 1KHz, 0.250VAC MAX., 25°C±1°C)
 LINE TO GROUND: 0.0028 µF ±20%
 LINE TO LINE: 0.1000 µF ±20%
 DISCHARGE RESISTOR: 3.3 MΩ
 L/G AND L/L I.R.: NO DISCHARGE RESISTOR: 6000MΩ (MIN.) @ 100VDC, 20°C AND 50% RH

RECOMMENDED RECEIVING INSPECTION HIPOT:

LINE TO GROUND: 1500 VAC FOR 1 MINUTE
 LINE TO LINE: 1450 VDC FOR 1 MINUTE

FILTER APPROVAL:

THE BEST WAY TO SELECT AND QUALIFY A FILTER IS FOR YOUR ENGINEERING TO TEST THE UNIT IN YOUR EQUIPMENT.

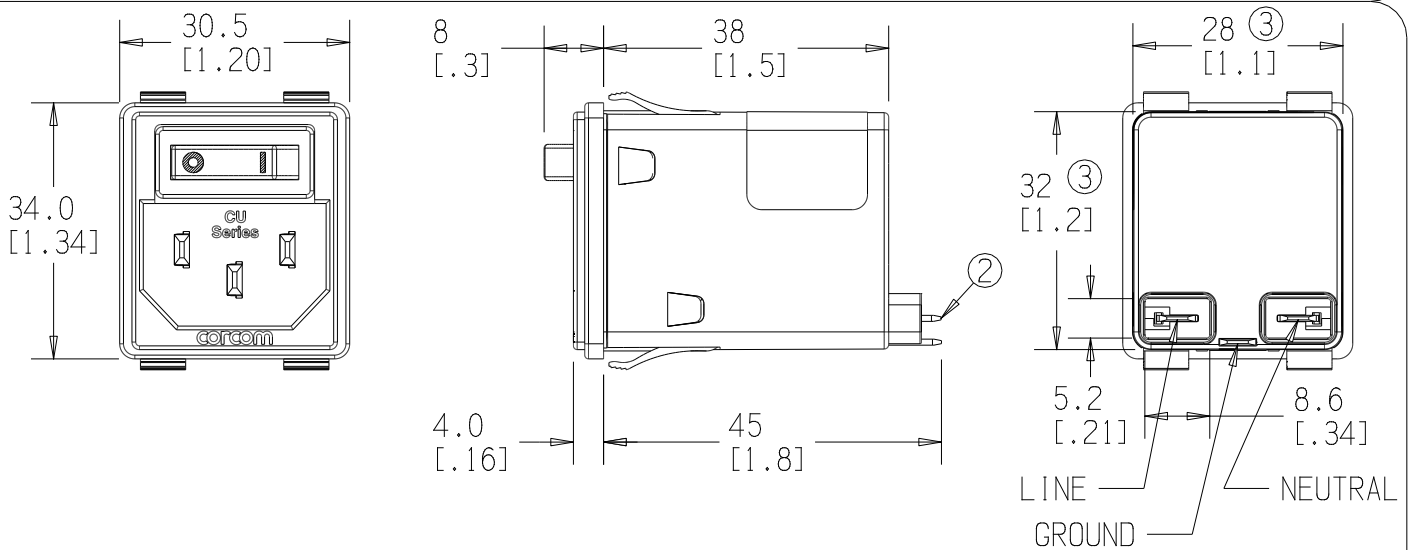

NOTES:

1. SOCKET COMPLIES WITH EN 60320-1.
- ②. LOAD TERMINALS COMPLY WITH DIN 46244, 4.8MM X 0.8MM.
- ③. DIMENSION APPLIES AT LABEL ONLY. FORCE REQUIRED FOR INSTALLATION.

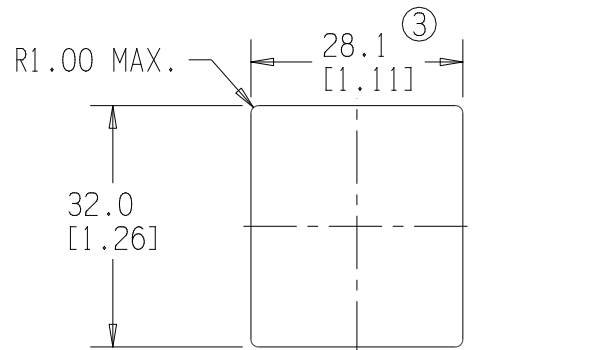

RECOMMENDED PANEL CUTOUT ±0.1 MM THICKNESS: 0.63-2.1 MM

50 Ω - 50 Ω (MINIMUM) INSERTION LOSS											
FREQUENCY MHz	.05	.15	.5	1	5	10	30	/	/	/	/
COMMON dB	0	1	10	13	25	27	42	/	/	/	/
DIFF. dB	1	10	20	23	28	39	54	/	/	/	/

THIS INFORMATION IS CONFIDENTIAL AND PROPRIETARY TO TYCO ELECTRONICS CORPORATION AND ITS WORLDWIDE SUBSIDIARIES AND AFFILIATES. IT MAY NOT BE DISCLOSED TO ANYONE OTHER THAN TYCO ELECTRONICS PERSONNEL, WITHOUT WRITTEN AUTHORIZATION FROM TYCO ELECTRONICS CORPORATION. HARRISBURG, PENNSYLVANIA USA.

PARTS SHALL COMPLY WITH TYCO ELECTRONICS 230-702 SPECIFICATION FOR HAZARDOUS SUBSTANCES UNLESS OTHERWISE SPECIFIED TOLERANCE TO BE ±0.5 MM MATERIAL & FINISH: AS SUPPLIED

Tyco Electronics
 CORCOM PRODUCTS, 620 S. BUTTERFIELD RD., MUNDELEIN IL 60060

POWER LINE FILTER

TYCO ELECTRONICS PART NO. 2-1609114-1

CVM AVAILABLE	YES	NO	
	X		

SCALE: 1:1 DATE: 30DEC08 DRAWING NUMBER: 15CUFS1 REV. 1

DRW. BY: EC ORTG: EC

G:\KeyCreator Directories\CD 15CUFS101.ckd