



Chipsmall Limited consists of a professional team with an average of over 10 year of expertise in the distribution of electronic components. Based in Hongkong, we have already established firm and mutual-benefit business relationships with customers from,Europe,America and south Asia,supplying obsolete and hard-to-find components to meet their specific needs.

With the principle of “Quality Parts,Customers Priority,Honest Operation,and Considerate Service”,our business mainly focus on the distribution of electronic components. Line cards we deal with include Microchip,ALPS,ROHM,Xilinx,Pulse,ON,Everlight and Freescale. Main products comprise IC,Modules,Potentiometer,IC Socket,Relay,Connector.Our parts cover such applications as commercial,industrial, and automotives areas.

We are looking forward to setting up business relationship with you and hope to provide you with the best service and solution. Let us make a better world for our industry!



Contact us

Tel: +86-755-8981 8866 Fax: +86-755-8427 6832

Email & Skype: info@chipsmall.com Web: www.chipsmall.com

Address: A1208, Overseas Decoration Building, #122 Zhenhua RD., Futian, Shenzhen, China



CUSTOMER DRAWING

SPECIFICATIONS ARE SUBJECT TO CHANGE WITHOUT NOTICE

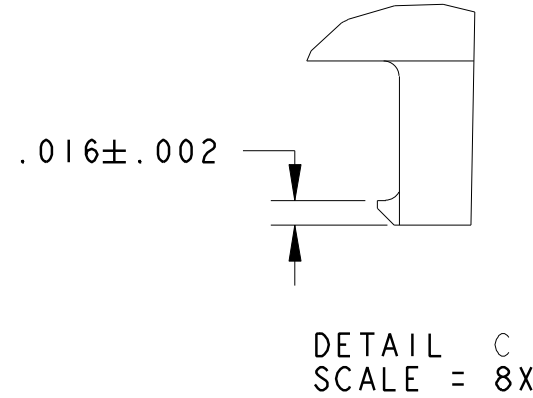
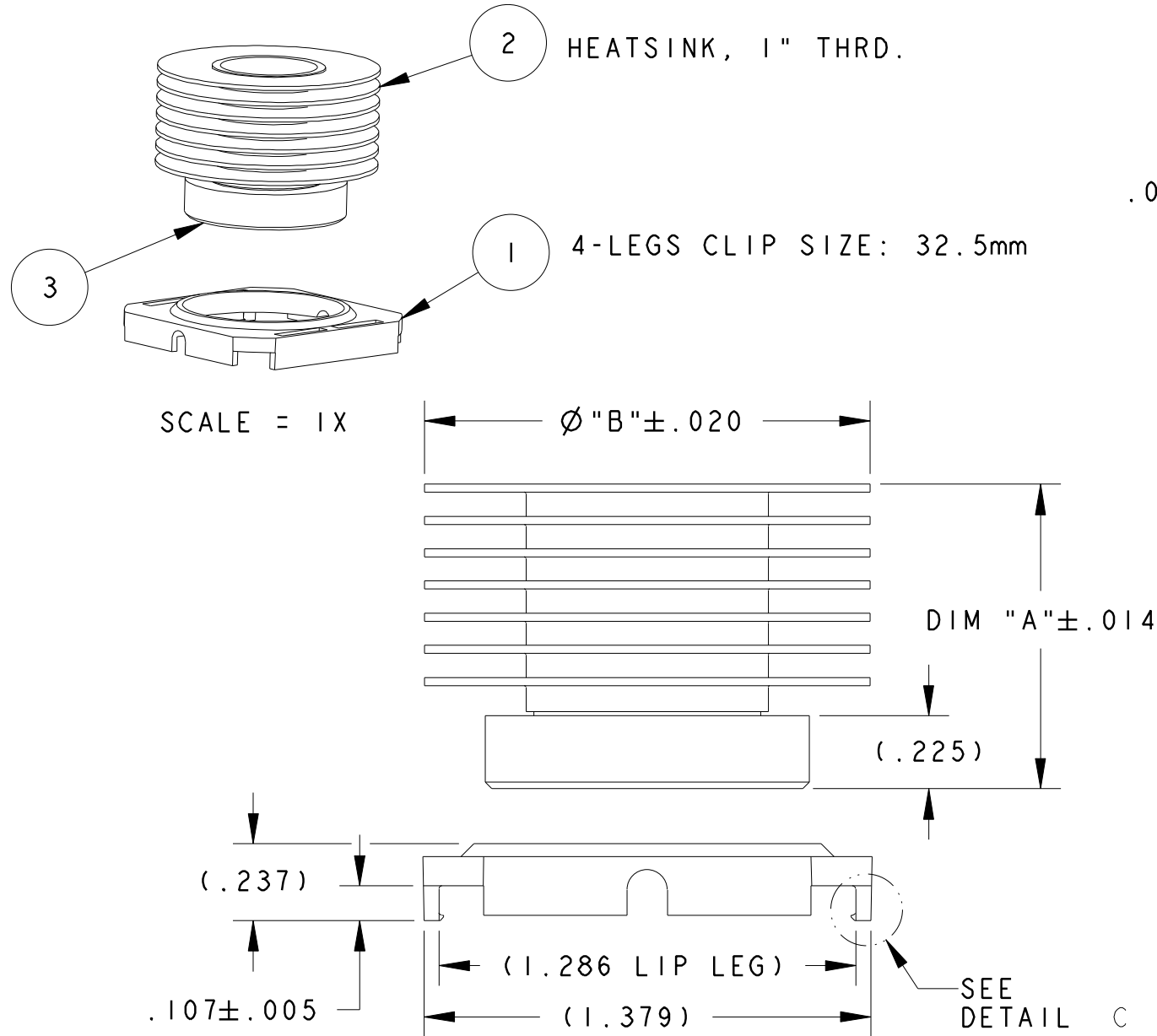

1. MATERIAL :

HEAT SINK: ALUMINUM
CLIP: BLACK PEI (UL94-V0)

2. BEFORE THE HEATSINK APPLICATION, THE USER SHOULD IDENTIFY THE SPECIFICATION OF MAXIMUM LOAD ON THE BGA PACKAGE.

SCREW DRIVER SLOT (.070 WIDE X .100 DEEP) PROVIDED IN THE CENTER PORTION OF THE HEAT SINK. FOR ACCURATE TORQUE SETTING, SCREW DRIVER BIT MUST BE ALIGNED TO THE CENTER LINE OF THE HEAT SINK.

HEATSINK TORQUE SPECIFICATIONS CONVERTED TO FORCE. BARE DIE PACKAGE:

- 2.0 POUND-FORCE INCH TORQUE = 8.1 POUND-FORCE (0.23 NEWTON METER TORQUE = 36.03 NEWTON)
- 2.5 POUND-FORCE INCH TORQUE = 10.1 POUND-FORCE (0.28 NEWTON METER TORQUE = 44.93 NEWTON)

FULL SIZE LID PACKAGE:

- 2.0 POUND-FORCE INCH TORQUE = 6.9 POUND-FORCE (0.23 NEWTON METER TORQUE = 30.69 NEWTON)
- 2.5 POUND-FORCE INCH TORQUE = 8.7 POUND-FORCE (0.28 NEWTON METER TORQUE = 38.70 NEWTON)

3. REMOVE CLIP WITH REMOVAL TOOL P/N: 1542616-1

4. RoHS COMPLIANT AND CERTIFIED.

3	INTERFACE	1
2	HEATSINK, 1" THRD.	1
1	MOUNTING CLIP	1
ITEM NO.	DESCRIPTION	QTY

TABLE 1 (BOM)

200 LFM	400 LFM	600 LFM				
3.20	2.10	1.75	2-1963557-7	Ø2.000" HS, 1" THRD, 7 FINS	2.000	.940
3.64	2.37	1.92	2-1963557-5	Ø2.000" HS, 1" THRD, 5 FINS	2.000	.740
3.97	2.57	2.05	2-1963557-4	Ø2.000" HS, 1" THRD, 4 FINS	2.000	.640
4.37	2.88	2.30	2-1963557-3	Ø2.000" HS, 1" THRD, 3 FINS	2.000	.540
4.77	3.21	2.54	2-1963557-2	Ø2.000" HS, 1" THRD, 2 FINS	2.000	.440
4.00	2.63	2.02	1-1963557-7	Ø1.375" HS, 1" THRD, 7 FINS	1.375	.940
4.55	2.96	2.29	1-1963557-5	Ø1.375" HS, 1" THRD, 5 FINS	1.375	.740
4.96	3.20	2.50	1-1963557-4	Ø1.375" HS, 1" THRD, 4 FINS	1.375	.640
5.45	3.61	2.81	1-1963557-3	Ø1.375" HS, 1" THRD, 3 FINS	1.375	.540
5.95	4.02	3.13	1-1963557-2	Ø1.375" HS, 1" THRD, 2 FINS	1.375	.440
Rca (°C/WATT)			ASSEMBLY HS PART NO.	DESCRIPTION	Ø"B"	DIM "A"

THERMAL PERFORMANCE

TABLE 2

REV.	DESCRIPTION	DATE
A	RELEASE	
AI	RELEASED	
B	RELEASED	
BI	RELEASED	

ERL 112104	APP'D: V.K. 5-4-07
E.TAO 5-4-07	APP'D: V.K. 5-24-07
APP'D: V.K. 5-4-07	APP'D: BP 10-18-07
ECO-07-023087	APP'D: B.P. 12-17-07
DA 10-1-07	
APP'D: BP 10-18-07	
ECR-07-030181	
ETAO 12-14-07	
APP'D: B.P. 12-17-07	

Tyco Electronics North Attleboro, Massachusetts 02760

UNLESS OTHERWISE SPECIFIED TOLERANCES ARE:

DRAWN BY: E.TAO	DATE: 5-4-07
ENGINEER: V. KHEIL	DATE: 5-4-07
FILENAME: C-1963557	PROJECT: PRO-E

MATERIAL: N/A
FINISH: N/A

CONFIDENTIAL PROPERTY OF TYCO ELECTRONICS. NOT TO BE DISCLOSED TO OTHERS. REPRODUCED OR USED FOR ANY PURPOSES EXCEPT AS AUTHORIZED IN WRITING BY AN AUTHORIZED OFFICIAL OF TYCO ELECTRONICS. MUST BE RETURNED TO TYCO ELECTRONICS ON DEMAND, ON COMPLETION OF ORDER OR OTHER PURPOSES FOR WHICH LENT.

DIMENSIONS ARE IN: INCHES
SCALE: 2:1
SIZE: B
THIRD ANGLE PROJECTION

TITLE: ASSEMBLY HEATSINK WITH 4 LEGS, 32.5mm CLIP	
TE PART NO.: SEE TABLE 2	SHEET 1 of 1
DWG. NO.: C-1963557	REV. BI