



Chipsmall Limited consists of a professional team with an average of over 10 year of expertise in the distribution of electronic components. Based in Hongkong, we have already established firm and mutual-benefit business relationships with customers from,Europe,America and south Asia,supplying obsolete and hard-to-find components to meet their specific needs.

With the principle of “Quality Parts,Customers Priority,Honest Operation,and Considerate Service”,our business mainly focus on the distribution of electronic components. Line cards we deal with include Microchip,ALPS,ROHM,Xilinx,Pulse,ON,Everlight and Freescale. Main products comprise IC,Modules,Potentiometer,IC Socket,Relay,Connector.Our parts cover such applications as commercial,industrial, and automotives areas.

We are looking forward to setting up business relationship with you and hope to provide you with the best service and solution. Let us make a better world for our industry!



Contact us

Tel: +86-755-8981 8866 Fax: +86-755-8427 6832

Email & Skype: info@chipsmall.com Web: www.chipsmall.com

Address: A1208, Overseas Decoration Building, #122 Zhenhua RD., Futian, Shenzhen, China



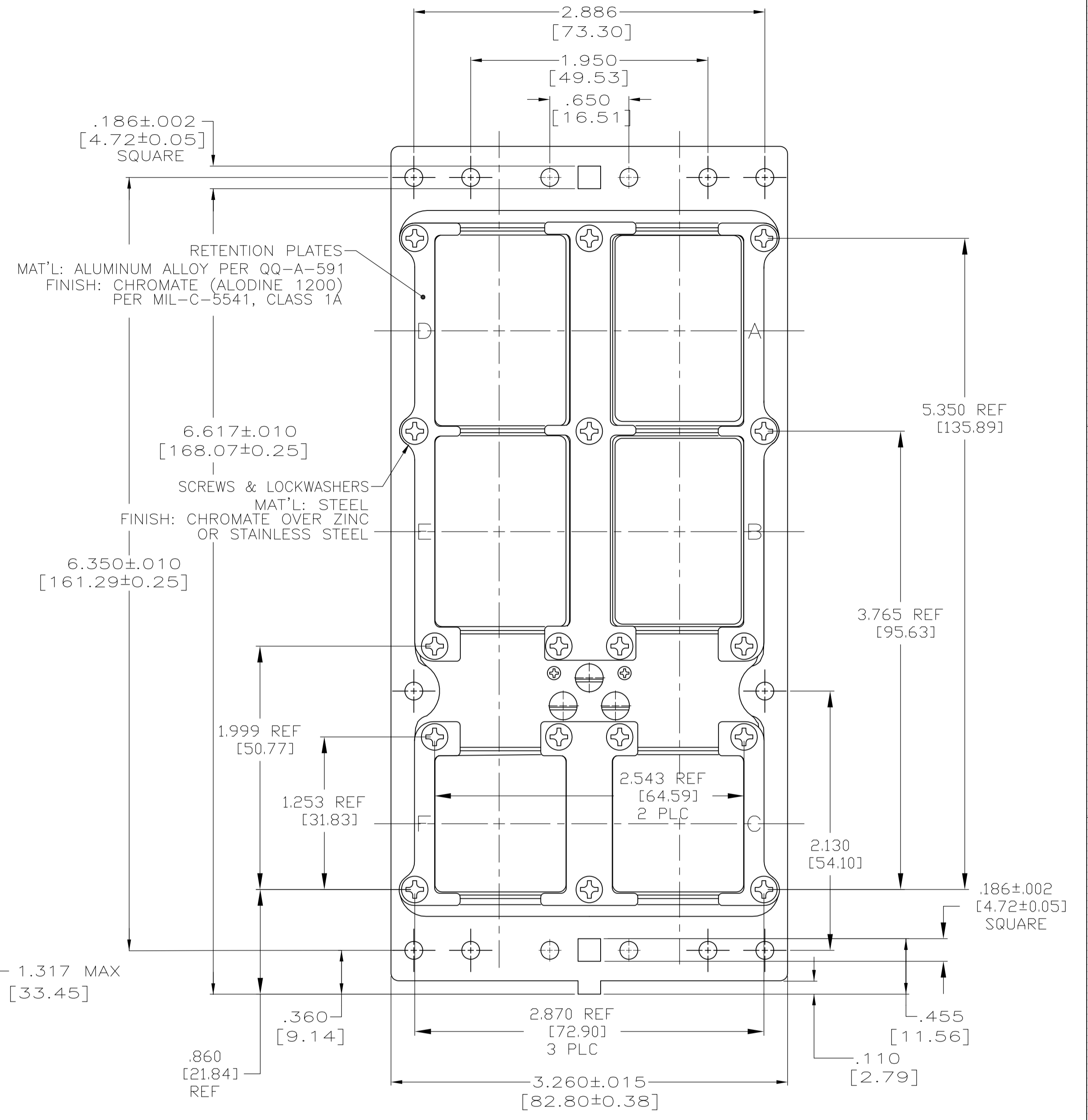
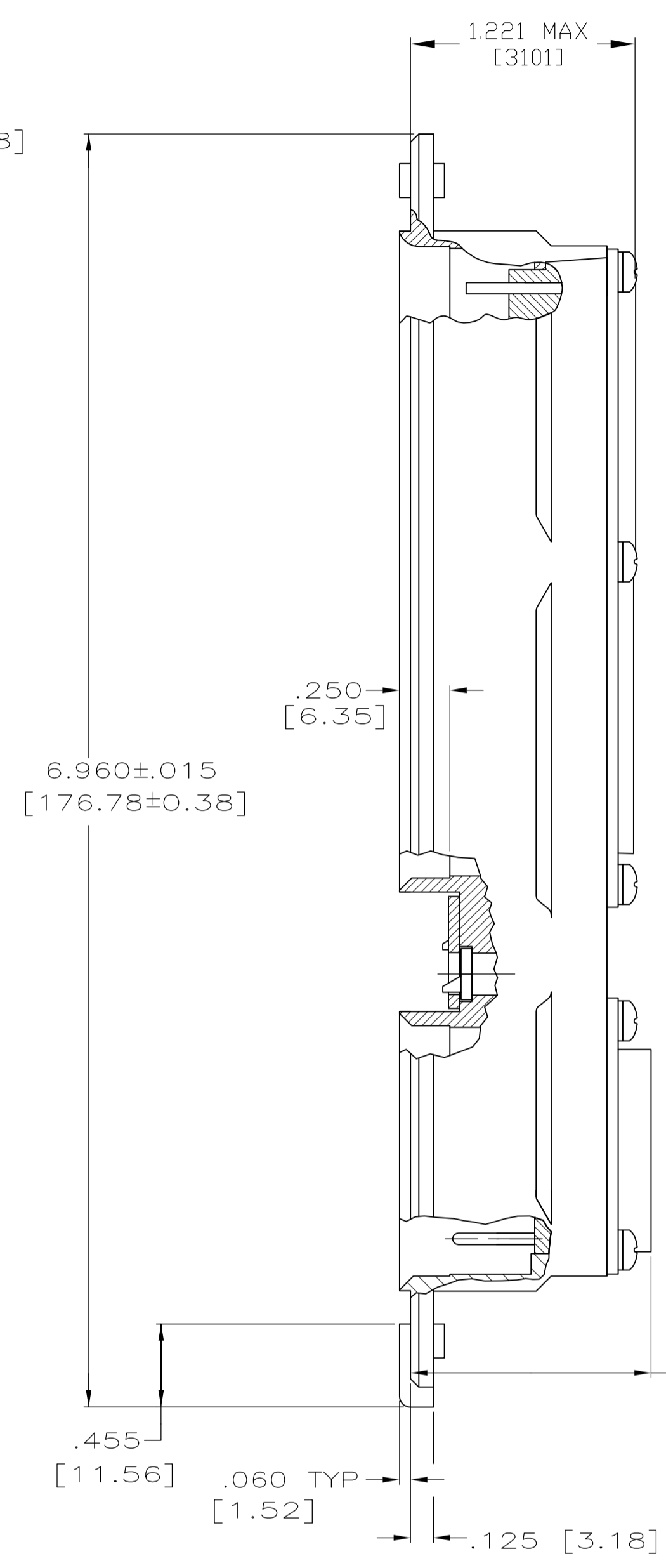
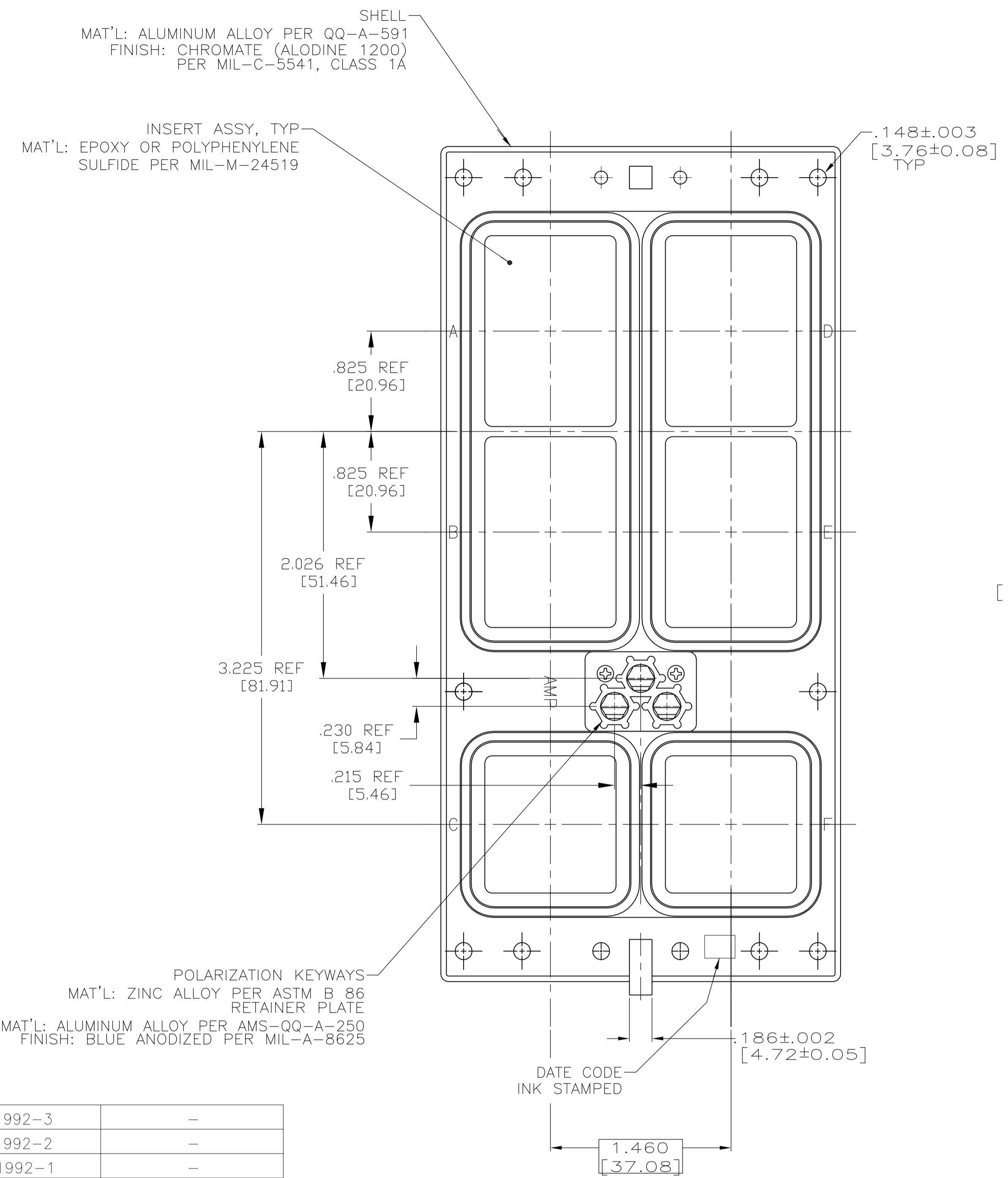

- CONTACTS ARE SHOWN IN POSITION FOR ILLUSTRATION ONLY. FOR SHIPMENT CONTACTS ARE INCLUDED IN A CONTAINER WITHIN THE CONNECTOR PACKAGE. COAX CONTACTS ARE NOT SUPPLIED AND MUST BE ORDERED SEPARATELY.
- ALL DIMENSIONS PER ARINC 600 SPECIFICATIONS.
- POLARIZING KEYS SHOWN IN POSITION 01 FOR ILLUSTRATION ONLY. CONNECTORS SHIPPED WITH KEYING PER ORDERING INSTRUCTIONS. CONTACT INSERTS AS SHOWN FOR ILLUSTRATION ONLY. SEE TABLE FOR DISCRIPTIVE NUMBER.
- FRONT RELEASE FEATURE PERTAINS TO SIGNAL INSERTS ONLY.

2-211992-3	-
2-211992-2	-
2-211992-1	-
2-211992-0	-
1-211992-9	-
1-211992-8	-
1-211992-7	-
1-211992-6	-
1-211992-5	-
1-211992-4	-
1-211992-3	NIC66J33FA00CA1
1-211992-2	-
1-211992-1	NIC66J31FA00CA1
1-211992-0	-
211992-9	-
211992-8	-
211992-7	NIC66J31FA27FA1
211992-6	NIC66J31FA03FA1
211992-5	NIC66J31FA01FH0
211992-4	NIC66J31FA01FF0
211992-3	NIC66J32FA00FA1
211992-2	-
211992-1	NIC66J31FA01FA1
PART NUMBER	DESCRIPTIVE NUMBER

-	-
-	-
-	-
-	-
-	-
-	-
-	-
-	-
-	-
-	-
-	-
-	-
2-211992-4	NIC66J31FA01FJ0
PART NUMBER	DESCRIPTIVE NUMBER

.025 SQUARE FRONT RELEASE #22 CONTACTS			.025 ROUND FRONT RELEASE #22 CONTACTS		
NUMBER OF WRAPS	MIN POST EXTENSION FROM REAR OF INSERT	AMP PART NUMBER	MIN EXTENSION FROM REAR OF INSERT	AMP PART NUMBER	
3	.500 [12.70]	211245-6	.375 [9.53]	211431-6	
2	.375 [9.53]	211245-4	.250 [6.35]	211431-4	
1	.250 [6.35]	211245-2	.150 [3.81]	211431-2	

PRELIMINARY NOT RELEASED FOR PRODUCTION

CONTACTS

THIS DRAWING IS A CONTROLLED DOCUMENT.

DWN: C.C.THOMAS 11-27-95
 CHK: R.GROSS 4-11-96
 APVD: R.GROSS 4-11-96

TOLERANCES UNLESS OTHERWISE SPECIFIED:
 0 PLC ± -
 1 PLC ± -
 2 PLC ± -
 3 PLC ± .005 [0.13]
 4 PLC ± -
 ANGLES ± -

APPLICATION SPEC: -
 WEIGHT: -

THIS DRAWING IS A CONTROLLED DOCUMENT.
 Tyco Electronics Corporation
 Harrisburg, PA 17105-3608

CONNECTOR ASSY, SIZE 3
 CLASS A, RCPT, ARINC 600
 FRONT RELEASE

SIZE: A1 CAGE CODE: 00779 DRAWING NO: 211992
 SCALE: 1:1 SHEET 1 OF 1 REV K