



Chipsmall Limited consists of a professional team with an average of over 10 year of expertise in the distribution of electronic components. Based in Hongkong, we have already established firm and mutual-benefit business relationships with customers from,Europe,America and south Asia,supplying obsolete and hard-to-find components to meet their specific needs.

With the principle of “Quality Parts,Customers Priority,Honest Operation,and Considerate Service”,our business mainly focus on the distribution of electronic components. Line cards we deal with include Microchip,ALPS,ROHM,Xilinx,Pulse,ON,Everlight and Freescale. Main products comprise IC,Modules,Potentiometer,IC Socket,Relay,Connector.Our parts cover such applications as commercial,industrial, and automotives areas.

We are looking forward to setting up business relationship with you and hope to provide you with the best service and solution. Let us make a better world for our industry!



## Contact us

Tel: +86-755-8981 8866 Fax: +86-755-8427 6832

Email & Skype: info@chipsmall.com Web: www.chipsmall.com

Address: A1208, Overseas Decoration Building, #122 Zhenhua RD., Futian, Shenzhen, China



THIS DRAWING IS UNPUBLISHED. RELEASED FOR PUBLICATION  
 © COPYRIGHT - By - ALL RIGHTS RESERVED.

LOC	DIST	REVISIONS					
FT	64	P	LTR	DESCRIPTION	DATE	DWN	APVD
		AA2		REVISED PER ECO-11-004835	11MAR11	RK	HMR

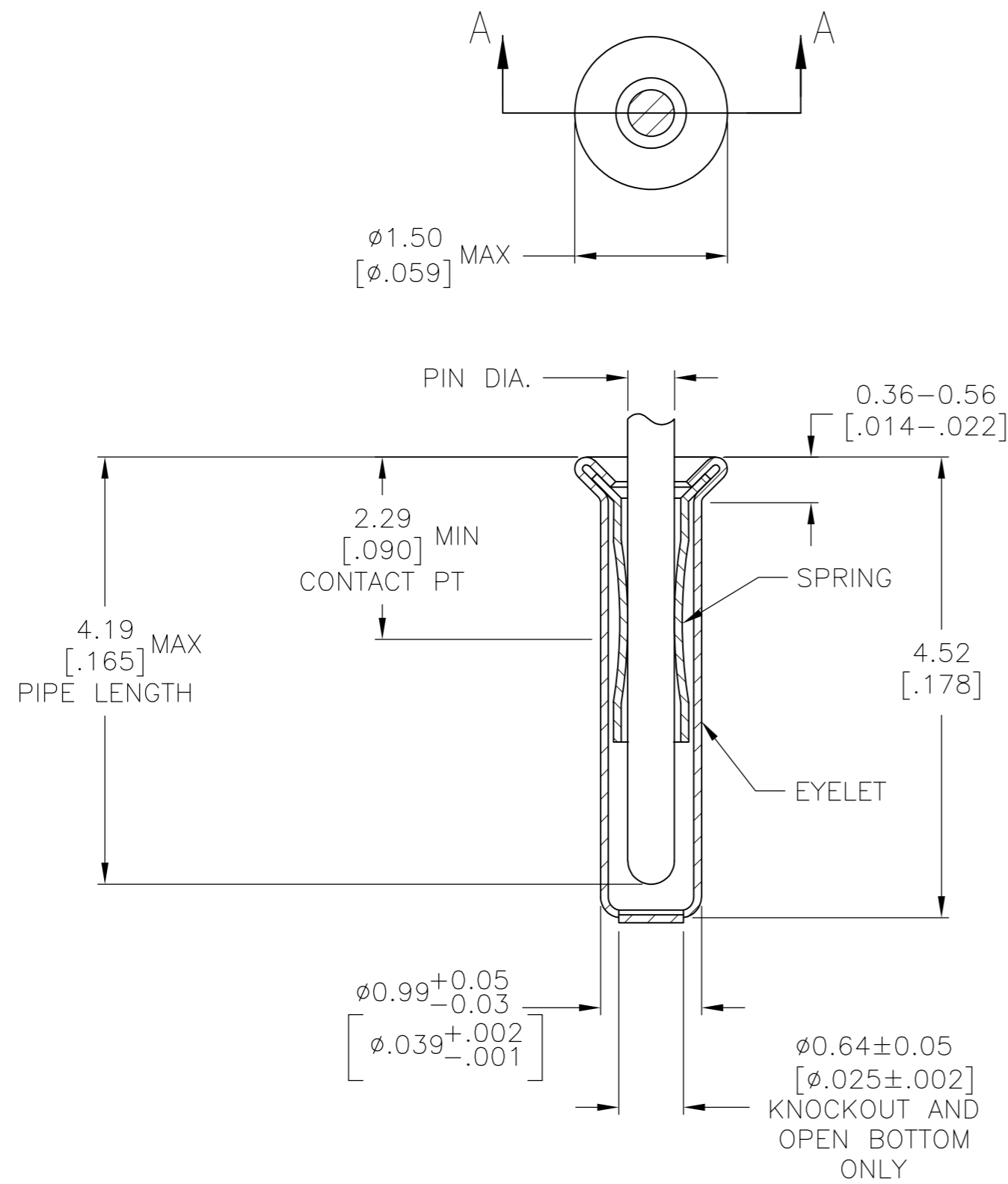

SECTION A-A

- 1. TIN PER MIL-T-10727 OR TIN LEAD .000254 [.000100] MIN THK.
- 2. GOLD PER MIL-G-45204, TYPE II, 0.00076 [.000030] MIN THK OVER NICKEL PER QQ-N-290 0.00028 [.000011] MIN THK ON CONTACT AREA.
- 3. GOLD FLASH PER MIL-G-45204, TYPE II, 0.13μm [.000005] MIN THK. OVER NICKEL PLATE PER QQ-N-290 0.51μm-1.52μm [.000020-.000060] EXT THK.
- 4. RECOMMENDED HOLE SIZE, PLATED OR UNPLATED:  
 MACHINE INSERTION: 1.04±0.03 [.041±.001]  
 HAND INSERTION: 1.04 <sup>+0.10</sup>/<sub>-0.00</sub> [.041<sup>+0.004</sup>/<sub>-0.000</sub>]
- 5. APPLICATION TOOL PART NUMBER:  
 MACHINE NO. 682127-2  
 INSERTION HEAD NO. 682039-1
- 6. TO INSURE PROPER SPRING TENSION DO NOT EXCEED A 0.10 [.004] DIFFERENCE IN PIN DIA WHEN CHANGING TO A SMALLER PIN.
- 7. BOTTOM PLUG KNOCKOUT TOOL PART NUMBER 69729 WITH TIP PART NUMBER 69728.
- 8. MATERIAL; SPRING: BERYLLIUM COPPER (QQ-C-533)  
 EYELET: COPPER (QQ-C-576)

SUPSD BY	OBSOLETE	OPEN	0.33-0.51 [.013-.020]	TIN	GOLD	2-332095-6
1-332095-9	OBSOLETE	KNOCKOUT	0.41-0.48 [.016-.019]	TIN		
	OBSOLETE	CLOSED				2-332095-4
	OBSOLETE	OPEN	0.33-0.51 [.013-.020]	GOLD		2-332095-3
		KNOCKOUT				2-332095-2
		CLOSED				2-332095-1
SUPSD BY 2-332095-6		OPEN	0.33-0.41 [.013-.016]		GOLD	2-332095-0
	OBSOLETE	KNOCKOUT	0.33-0.51 [.013-.020]	TIN		1-332095-9
SUPSD BY 2-332095-4		CLOSED				1-332095-8
SUPSD BY 2-332095-3		OPEN	0.33-0.41 [.013-.016]	GOLD		1-332095-7
SUPSD BY 2-332095-2		KNOCKOUT				1-332095-6
SUPSD BY 2-332095-1		CLOSED				1-332095-5
	OBSOLETE	CLOSED	0.33-0.51 [.013-.020]	TIN	TIN	1-332095-2
SUPSD BY 1-332095-2			0.33-0.41 [.013-.016]			332095
		BOTTOM TYPE	RECOMMENDED PIN DIA	EYELET	SPRING	PART NO
				FINISH		

THIS DRAWING IS A CONTROLLED DOCUMENT.		DWN R.TALLEY 4-5-91	TE Connectivity	
DIMENSIONS: mm [INCHES]		CHK -	NAME	
TOLERANCES UNLESS OTHERWISE SPECIFIED:		APVD -	MINIATURE SPRING SOCKET ASSEMBLY SERIES 1	
0 PLC ± -	1 PLC ± -	PRODUCT SPEC -	SIZE A2	CAGE CODE 00779
2 PLC ± -	3 PLC ± 0.20 [.008]	APPLICATION SPEC -	DRAWING NO C=332095	RESTRICTED TO -
4 PLC ± -	ANGLES ± -	WEIGHT -	SCALE 20:1	SHEET 1 OF 1
MATERIAL 8	FINISH SEE TABLE	CUSTOMER DRAWING	REV AA2	