



Chipsmall Limited consists of a professional team with an average of over 10 year of expertise in the distribution of electronic components. Based in Hongkong, we have already established firm and mutual-benefit business relationships with customers from,Europe,America and south Asia,supplying obsolete and hard-to-find components to meet their specific needs.

With the principle of “Quality Parts,Customers Priority,Honest Operation,and Considerate Service”,our business mainly focus on the distribution of electronic components. Line cards we deal with include Microchip,ALPS,ROHM,Xilinx,Pulse,ON,Everlight and Freescale. Main products comprise IC,Modules,Potentiometer,IC Socket,Relay,Connector.Our parts cover such applications as commercial,industrial, and automotives areas.

We are looking forward to setting up business relationship with you and hope to provide you with the best service and solution. Let us make a better world for our industry!



Contact us

Tel: +86-755-8981 8866 Fax: +86-755-8427 6832

Email & Skype: info@chipsmall.com Web: www.chipsmall.com

Address: A1208, Overseas Decoration Building, #122 Zhenhua RD., Futian, Shenzhen, China



THIS DRAWING IS UNPUBLISHED. RELEASED FOR PUBLICATION
 © COPYRIGHT BY TYCO ELECTRONICS CORPORATION. ALL RIGHTS RESERVED.

LOC	DIST	REVISIONS			
P	LTR	DESCRIPTION	DATE	DWN	APVD
G	14				
		D	REDRAWN PER 0G3A-0601-03	30SEPT03	JR MS

- 1 FOREIGN PRODUCTION ONLY
- 2 TIN PLATE PER ASTM B545, ANNEALED.
- 3 TONGUE THK IS .031±.002

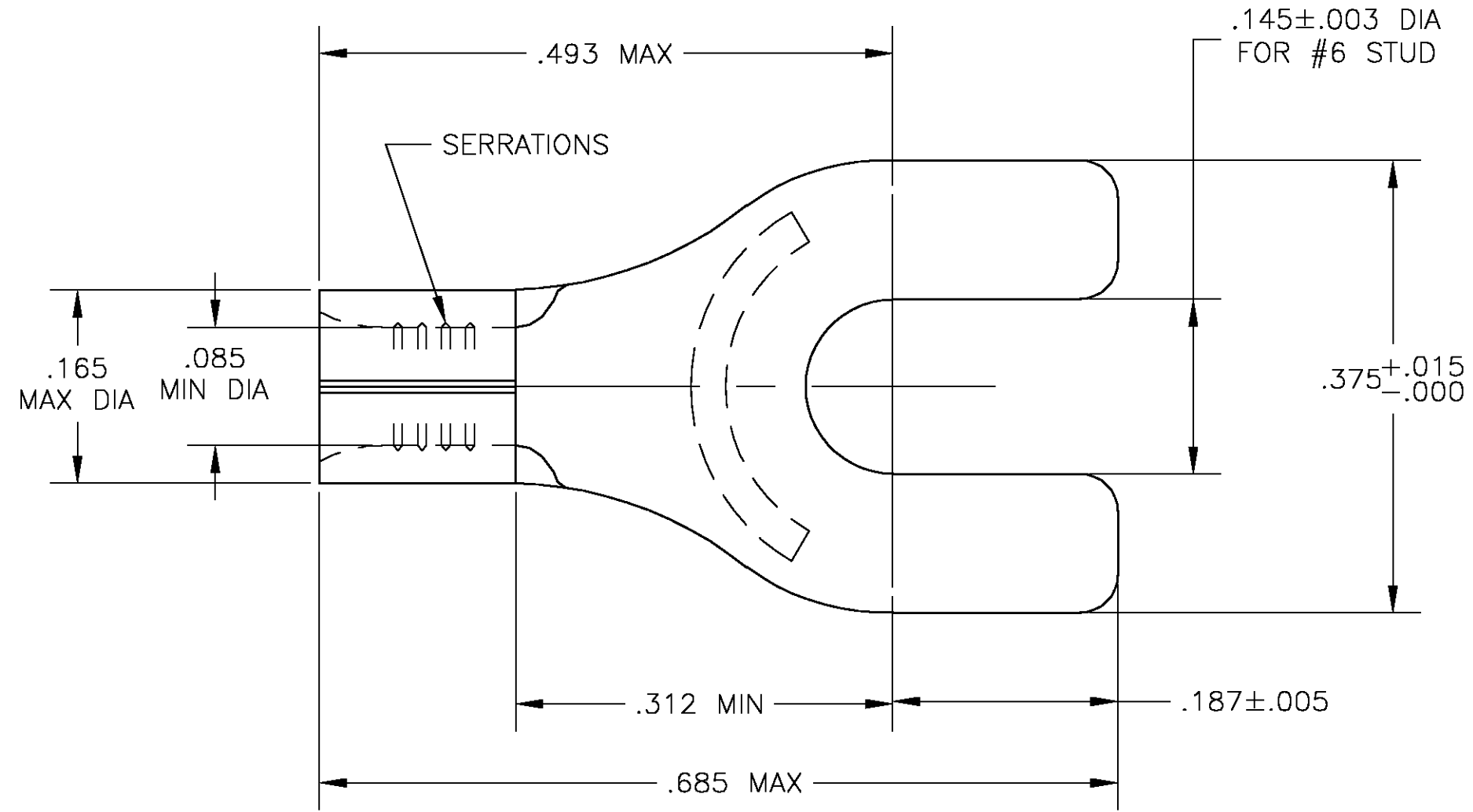

34127-0
 PART NO

THIS DRAWING IS A CONTROLLED DOCUMENT.		DWN jr_ruth 30SEPT03	Tyco Electronics Corporation Harrisburg, PA 17105		
DIMENSIONS: INCHES		CHK MJ SPICER 30SEPT03			
		APVD MJ SPICER 30SEPT03	NAME TERMINAL SOLISTRAND, SPADE WIRE SIZE: 16-14		
TOLERANCES UNLESS OTHERWISE SPECIFIED:		PRODUCT SPEC	RESTRICTED TO		
0 PLC ± -		APPLICATION SPEC	SIZE	CAGE CODE	DRAWING NO
1 PLC ± -		—	A3	00779	C-34127
2 PLC ± -		—	SCALE 8:1 SHEET 1 OF 1 REV D		
3 PLC ± .008		—			
4 PLC ± -		—			
ANGLES ± 5'		WEIGHT			
FINISH		—			
MATERIAL COPPER ASTM B152		CUSTOMER DRAWING			