



Chipsmall Limited consists of a professional team with an average of over 10 year of expertise in the distribution of electronic components. Based in Hongkong, we have already established firm and mutual-benefit business relationships with customers from,Europe,America and south Asia,supplying obsolete and hard-to-find components to meet their specific needs.

With the principle of "Quality Parts,Customers Priority,Honest Operation,and Considerate Service",our business mainly focus on the distribution of electronic components. Line cards we deal with include Microchip,ALPS,ROHM,Xilinx,Pulse,ON,Everlight and Freescale. Main products comprise IC,Modules,Potentiometer,IC Socket,Relay,Connector.Our parts cover such applications as commercial,industrial, and automotives areas.

We are looking forward to setting up business relationship with you and hope to provide you with the best service and solution. Let us make a better world for our industry!



Contact us

Tel: +86-755-8981 8866 Fax: +86-755-8427 6832

Email & Skype: info@chipsmall.com Web: www.chipsmall.com

Address: A1208, Overseas Decoration Building, #122 Zhenhua RD., Futian, Shenzhen, China





**zX2 Daughtercard and
RAM Removal Tool**

**Application Tooling
Specification Sheet**

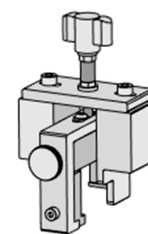

Order No. 200199-1170

FEATURES

- This tool is designed for the removal of 6 x 12 zX2 daughtercards and right angle signal modules from a PCB

SCOPE

Products: 6 x 12 zX2 daughtercards and right angle signal modules. See product list below for order numbers.

Product List

The following is a partial list of the product order numbers and their specifications that this tool is designed to run. Updates to this list are available on www.molex.com.

Series No.	Guide Style	Columns	Assembly Order Number			
172540	Unguided	12	172540-1001	172540-1022	172540-9222	172540-9322
	Left	12	172540-3022			
	Right	12	172540-5022			
172550	Unguided	12	172550-1206	172550-1207	172550-1208	

DESCRIPTION

Figure 1 illustrates the principal parts of the removal tool in the daughtercard removal configuration.

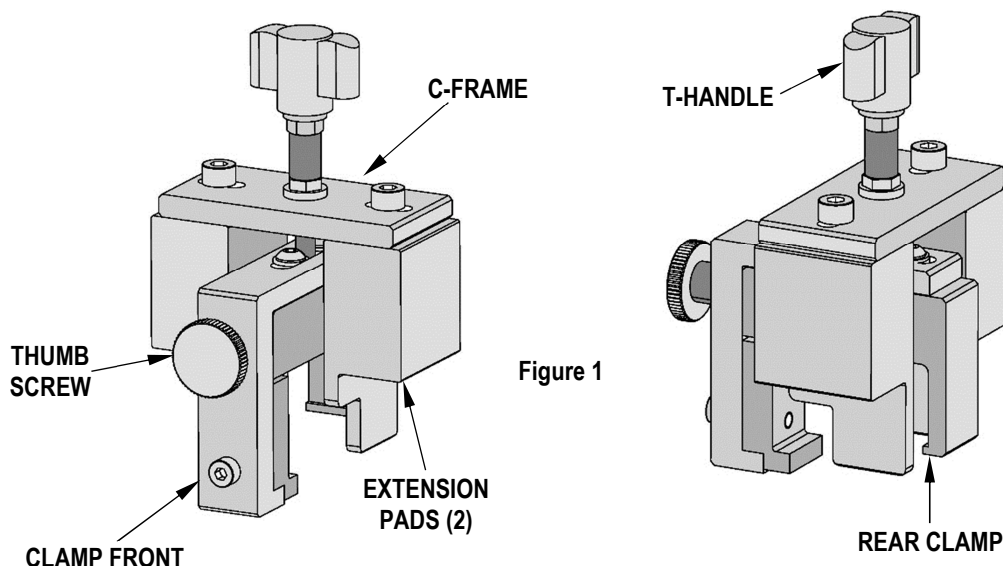

Figure 1

Tool Restrictions

These tools require a “Keep Out Zone” on the open side of the daughtercard that is free of components. The right and left sides should be 4mm (0.16 in). See Figure 2. This is a general requirement regardless of the module being removed.

Note: Be sure that all parts of the removal tool will clear any components on the printed circuit board during use. Tape may also be placed over circuit traces or on the bottom of the extension pads for added protection of the printed circuit board.

Tool Operation

1. Turn the T-handle counterclockwise until the clamp assembly is free of the upper frame.
2. Turn the thumb screw counterclockwise so the clamp front can open to fit over the daughtercard shroud. See Figure 3.
3. Position the rear clamp so that it is flush with the side of the outer wafer. The “teeth” of the rear clamp should fit snugly in the cutouts of the wafers. See Figure 4.
4. Turn the thumb screw clockwise to close the clamp tightly against the daughtercard.
5. Position the tool frame over the closed clamp, and turn the T-handle clockwise until the extension pads contact the PCB surface. See Figure 5.
6. Continue turning the T-handle clockwise until the daughtercard is free from the PCB.
7. Move the extraction tool away from the PCB. Turn the thumb screw counterclockwise to open the clamp and daughtercard from the extractor tool. Discard the daughtercard module.

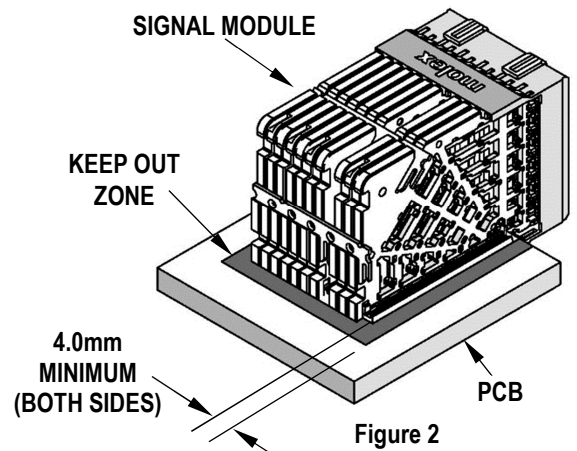

Figure 2

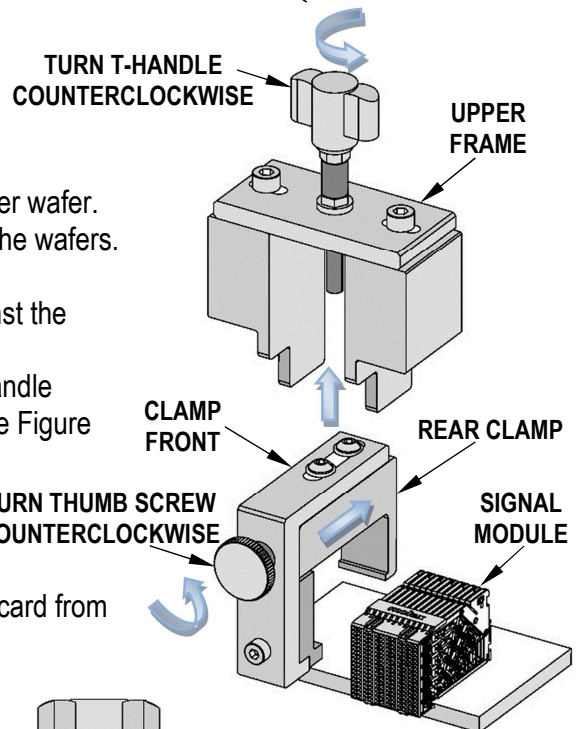

Figure 3

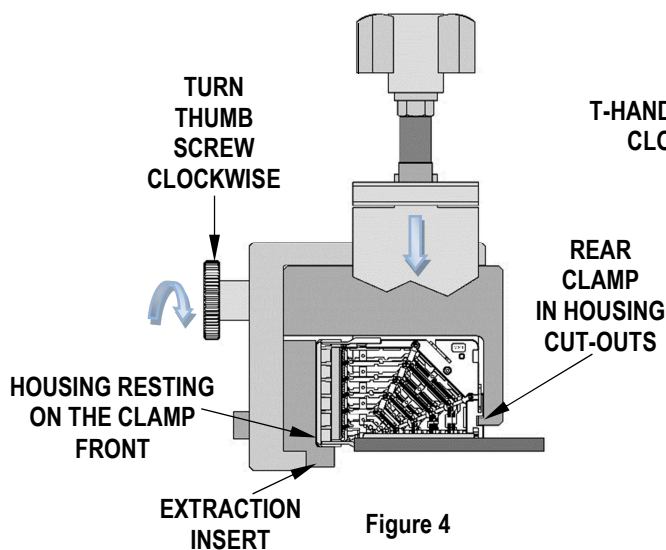

Figure 4

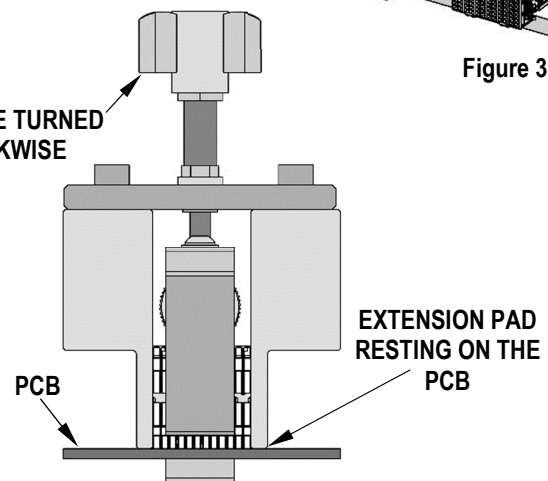

Figure 5

Daughtercard Module Assembly Removal (When mounted alongside other daughtercards)

When daughtercard modules are stacked end to end on one side, the extractor tool can be adjusted to allow the removal of the desired daughtercard module.

1. Remove the M5 x 10 long SHCS on the side where the extra module is located. See Figure 6.
2. Rotate the extension pad 180°.
3. Reinstall the extension pad with the M5 x 10 long SHCS.
4. Follow the tool operation procedure for daughtercard removal.

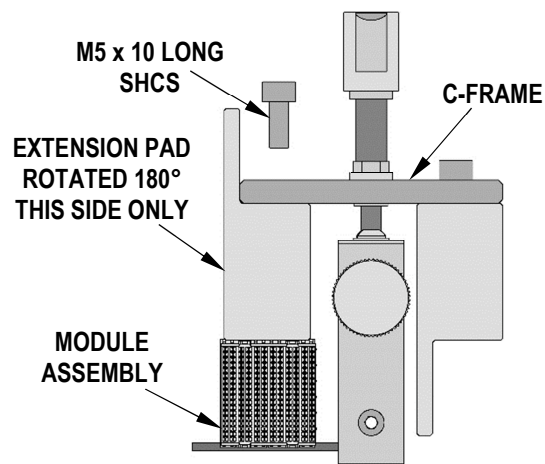

Figure 6

Daughtercard Module Assembly Removal (With daughtercard assemblies on both sides)

When daughtercard modules are stacked end to end on both sides, the extractor tool can be adjusted to allow the removal of the middle daughtercard module.

1. Remove the M5 x 14 long SHCS on each side where the extra modules are located. See Figure 7.
2. Rotate the extension pads 180°.
3. Reinstall the extension pads with the M5 x 10 long SHCS.
4. Follow the tool operation procedure for daughtercard removal.

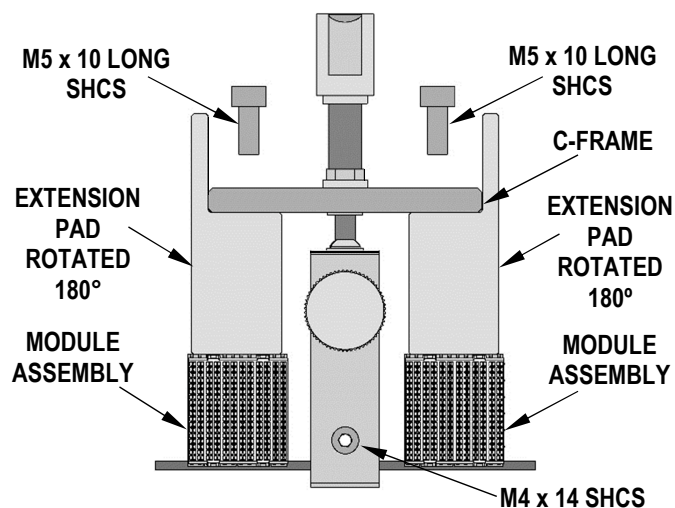

Figure 7

Switching Tooling for RAM from Daughtercard

1. Remove the M4 x 14 SHCS from the clamp front and extraction insert.
2. Move the extraction insert to the thumb screw side of the clamp front.
3. Insert the M4 x 14 SHCS through the clamp front, and screw it into the extraction insert.

DESCRIPTION

Figure 8 illustrates the principal parts of the removal tool in the RAM removal configuration.

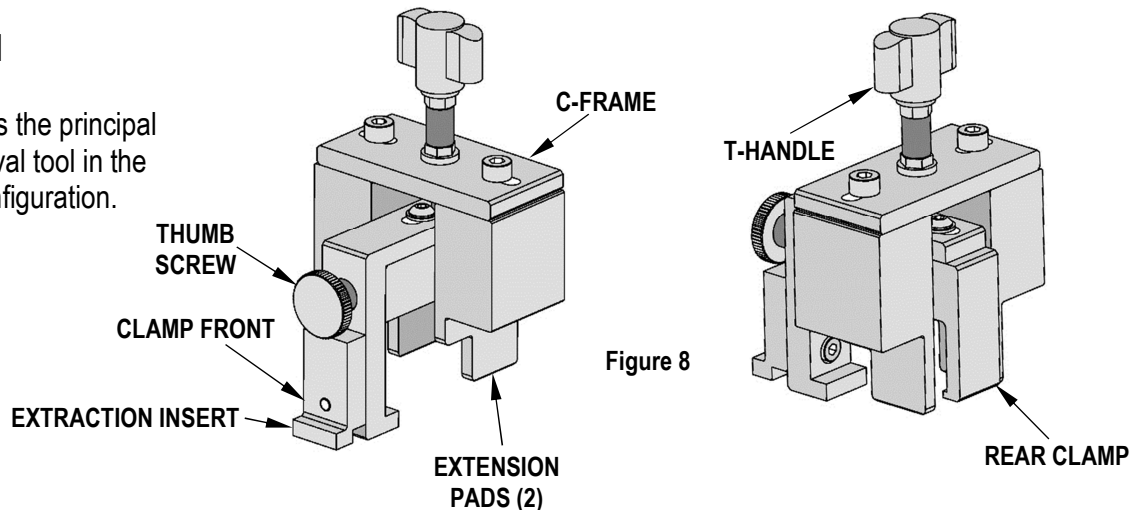

Figure 8

Tool Restrictions

These tools require a “Keep Out Zone” on the open side of the right angle module (RAM) that is free of components. The right and left sides should be 4mm (0.16 in). See Figure 9. This is a general requirement regardless of the module being removed.

Note: Be sure that all parts of the removal tool will clear any components on the printed circuit board during use. Tape may also be placed over circuit traces or on the bottom of the extension pads for added protection of the printed circuit board.

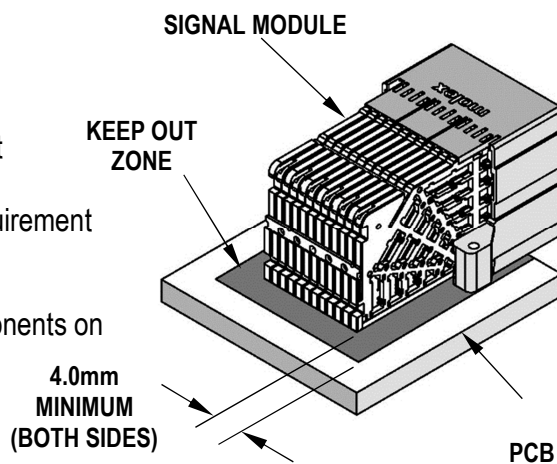

Figure 9

Tool Operation

1. Turn the T-handle counterclockwise until the clamp assembly is free of the upper frame.
2. Turn the thumb screw counterclockwise so the clamp front can open to fit over the RAM shroud. See Figure 10.
3. Position the rear clamp so that it is flush with the side of the outer wafer. The “teeth” of the rear clamp should fit snugly in the cutouts of the wafers. See Figure 11.
4. Turn the thumb screw clockwise to close the clamp tightly against the RAM.
5. Position the tool frame over the closed clamp, and turn the T-handle clockwise until the extension pads contact the PCB surface. See Figure 12.
6. Continue turning the T-handle clockwise until the RAM is free from the PCB.
7. Move the extraction tool away from the PCB. Turn the thumb screw counterclockwise to open the clamp and RAM from the extractor tool. Discard the RAM.

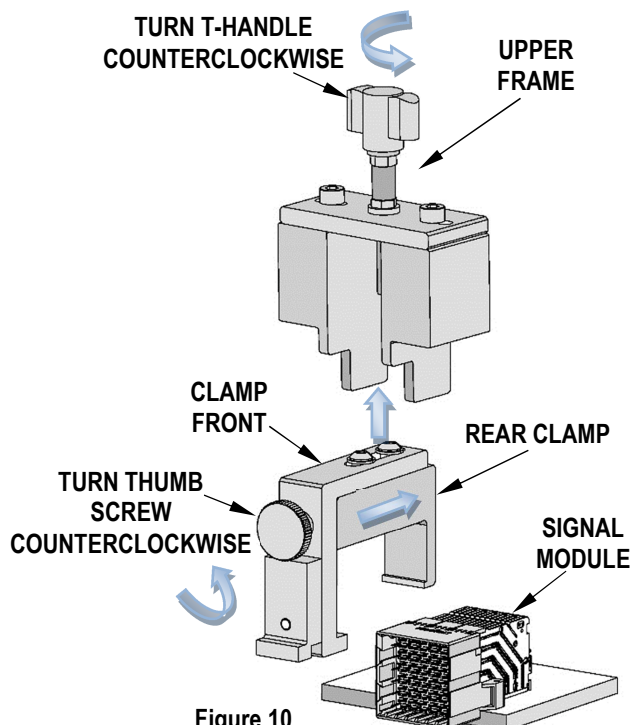
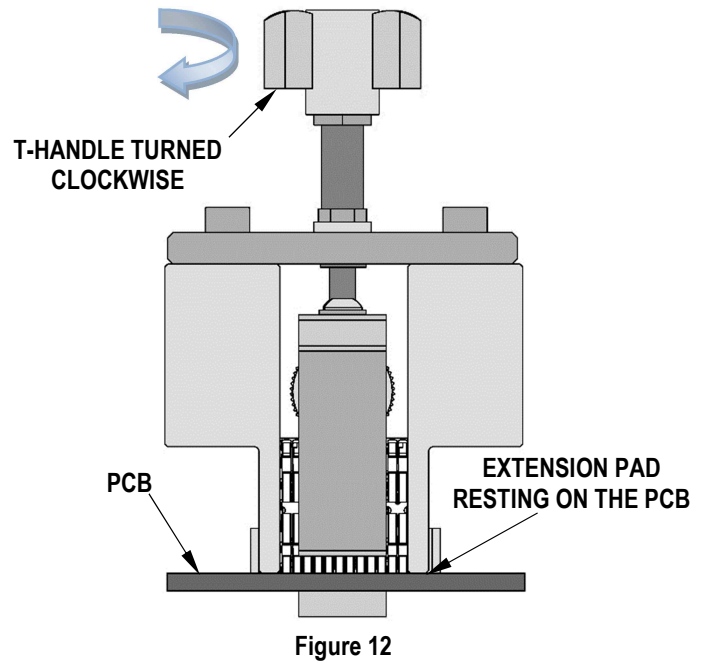
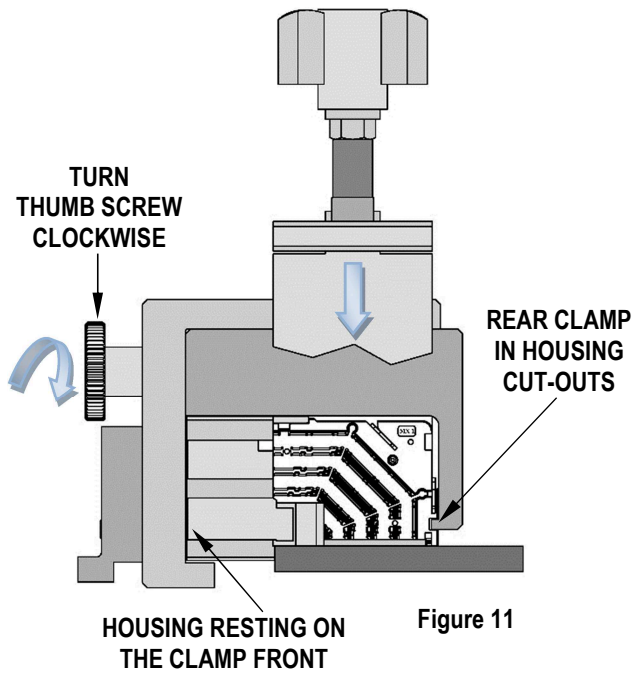

Figure 10



**RAM Assembly Removal
(When mounted alongside other RAM assemblies)**

When right angle modules are stacked end to end on one side, the extractor tool can be adjusted to allow the removal of the desired right angle module.

1. Remove the M5 x 10 long SHCS on the side where the extra module is located. See Figure 13.
2. Rotate the extension pad 180°.
3. Reinstall the extension pad with the M5 x 10 long SHCS.
4. Follow the tool operation procedure for RAM removal.

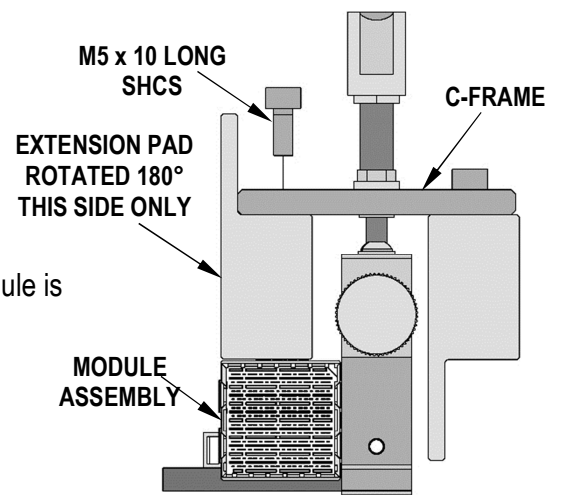

Figure 13

**RAM Assembly Removal
(With RAM assemblies on both sides)**

When right angle modules are stacked end to end on both sides, the extractor tool can be adjusted to allow the removal of the middle RAM.

1. Remove the M5 x 14 long SHCS on each side where the extra modules are located. See Figure 14.
2. Rotate the extension pads 180°.
3. Reinstall the extension pads with the M5 x 10 long SHCS.
4. Follow the tool operation procedure for RAM removal.

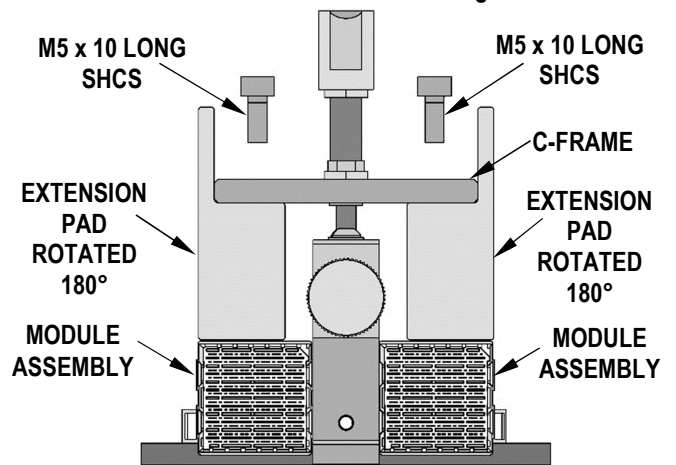

Figure 14

Switching Tooling for Daughtercard from RAM

1. Remove the M4 x 14 SHCS from the clamp front and extraction tool.
2. Move the extraction inserts to the inside of the clamp front.
3. Insert the M4 x 14 SHCS through the clamp front, and screw it into the extraction insert.

Maintenance

It is recommended that each operator of the tool be made aware of and responsible for the following maintenance steps:

1. Remove dust, moisture and other contaminants with a clean brush or a soft, lint-free cloth.
2. Do not use any abrasive materials that could damage the tool.
3. Make certain all pins, pivot points and bearing surfaces are protected with a thin coat of high-quality machine oil. Do not oil excessively.
4. When the tool is not in use, store it in a clean, dry area.

CAUTION: Molex specifications are valid only when used with Molex terminals, applicators and tooling.

Application Tooling Support

Phone: (402) 458-TOOL (8665)

E-Mail: applicationtooling@molex.com

Website: www.molex.com/applicationtooling

Molex is a registered trademark of Molex, LLC in the United States of America and may be registered in other countries; all other trademarks listed herein belong to their respective owners.