



Chipsmall Limited consists of a professional team with an average of over 10 year of expertise in the distribution of electronic components. Based in Hongkong, we have already established firm and mutual-benefit business relationships with customers from,Europe,America and south Asia,supplying obsolete and hard-to-find components to meet their specific needs.

With the principle of “Quality Parts,Customers Priority,Honest Operation,and Considerate Service”,our business mainly focus on the distribution of electronic components. Line cards we deal with include Microchip,ALPS,ROHM,Xilinx,Pulse,ON,Everlight and Freescale. Main products comprise IC,Modules,Potentiometer,IC Socket,Relay,Connector.Our parts cover such applications as commercial,industrial, and automotives areas.

We are looking forward to setting up business relationship with you and hope to provide you with the best service and solution. Let us make a better world for our industry!



Contact us

Tel: +86-755-8981 8866 Fax: +86-755-8427 6832

Email & Skype: info@chipsmall.com Web: www.chipsmall.com

Address: A1208, Overseas Decoration Building, #122 Zhenhua RD., Futian, Shenzhen, China



REVISIONS				
P.	LTN	DESCRIPTION	DATE	APPROV
D		REVISED PER ECO-15-017922	12APR2016	AP RP

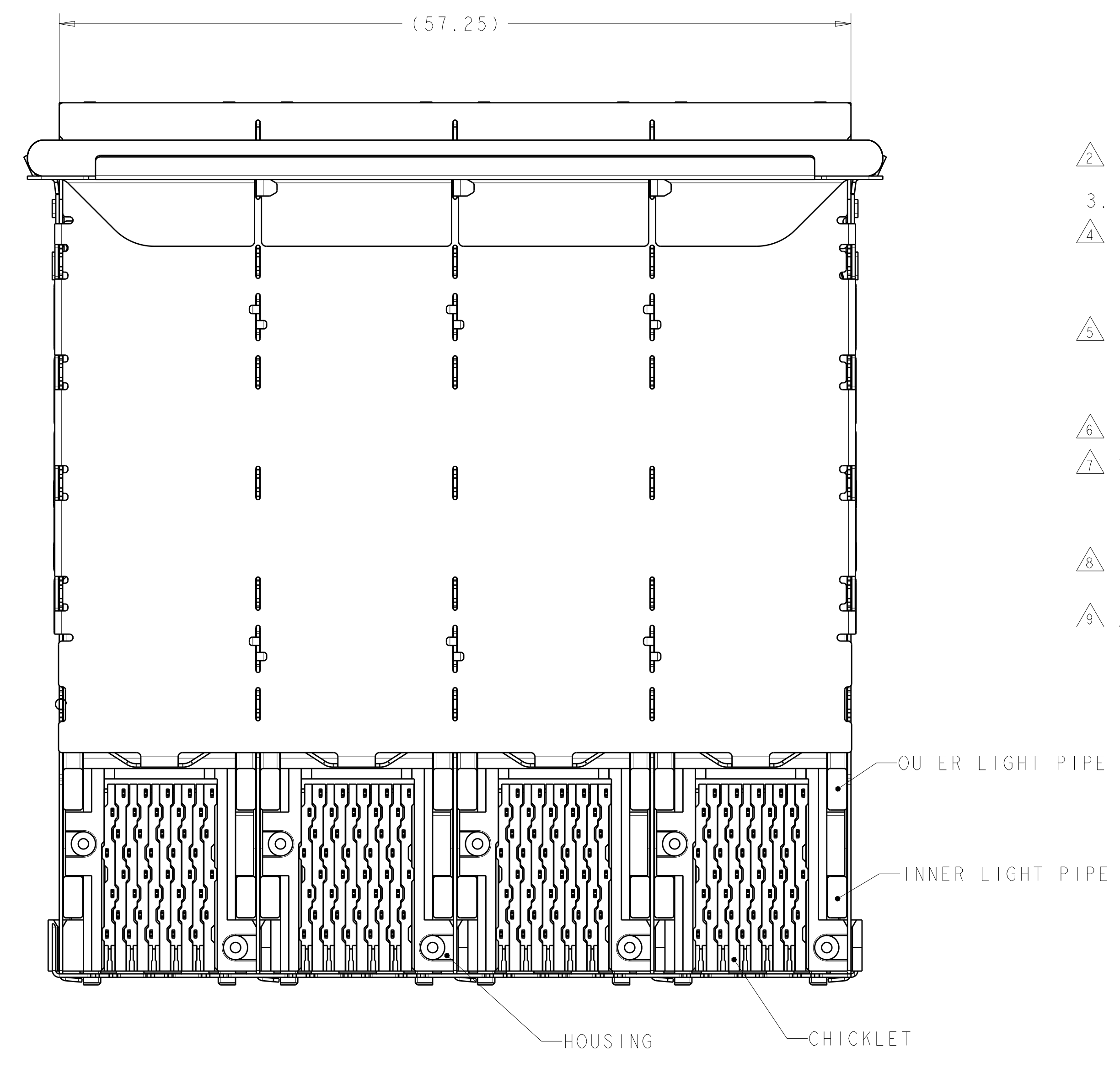
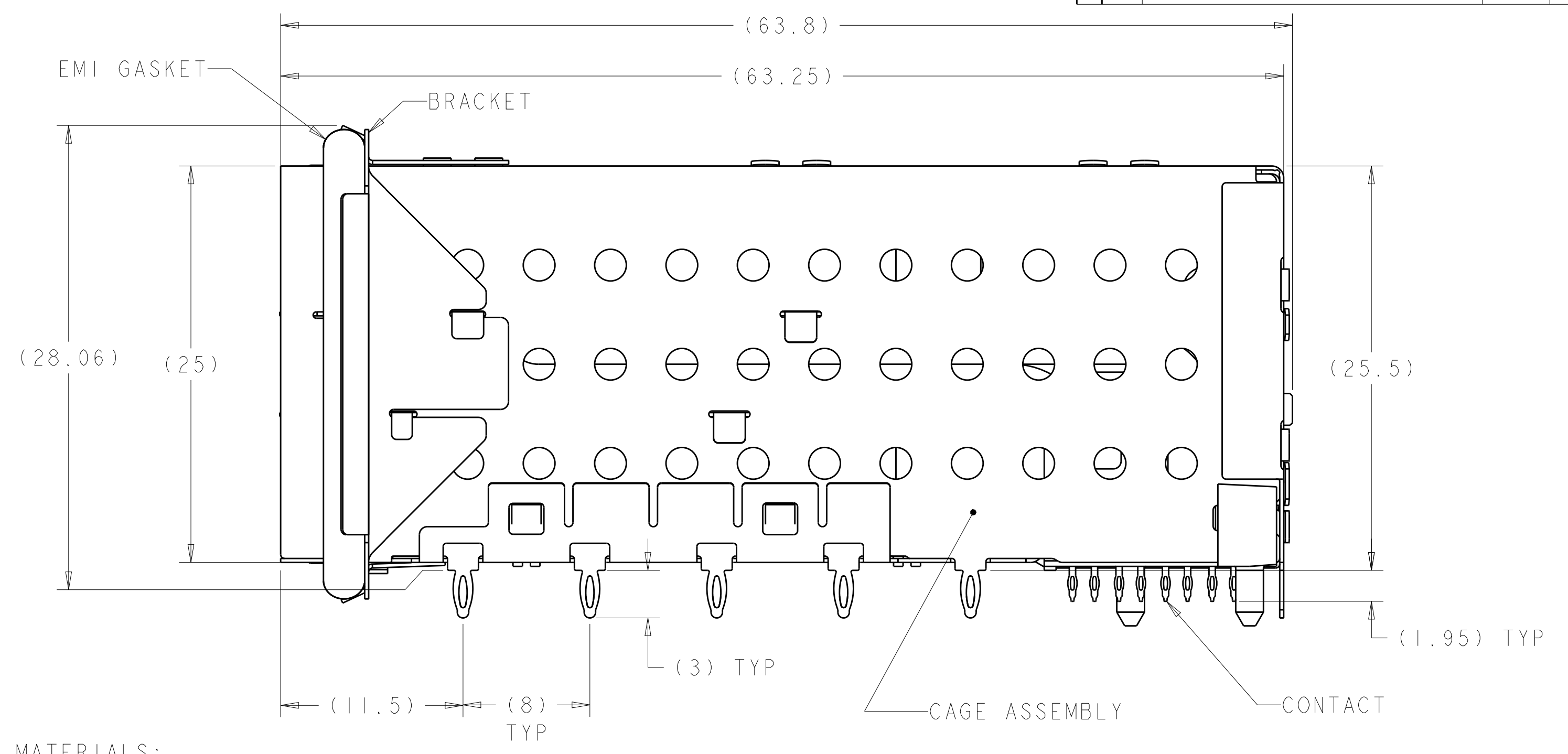
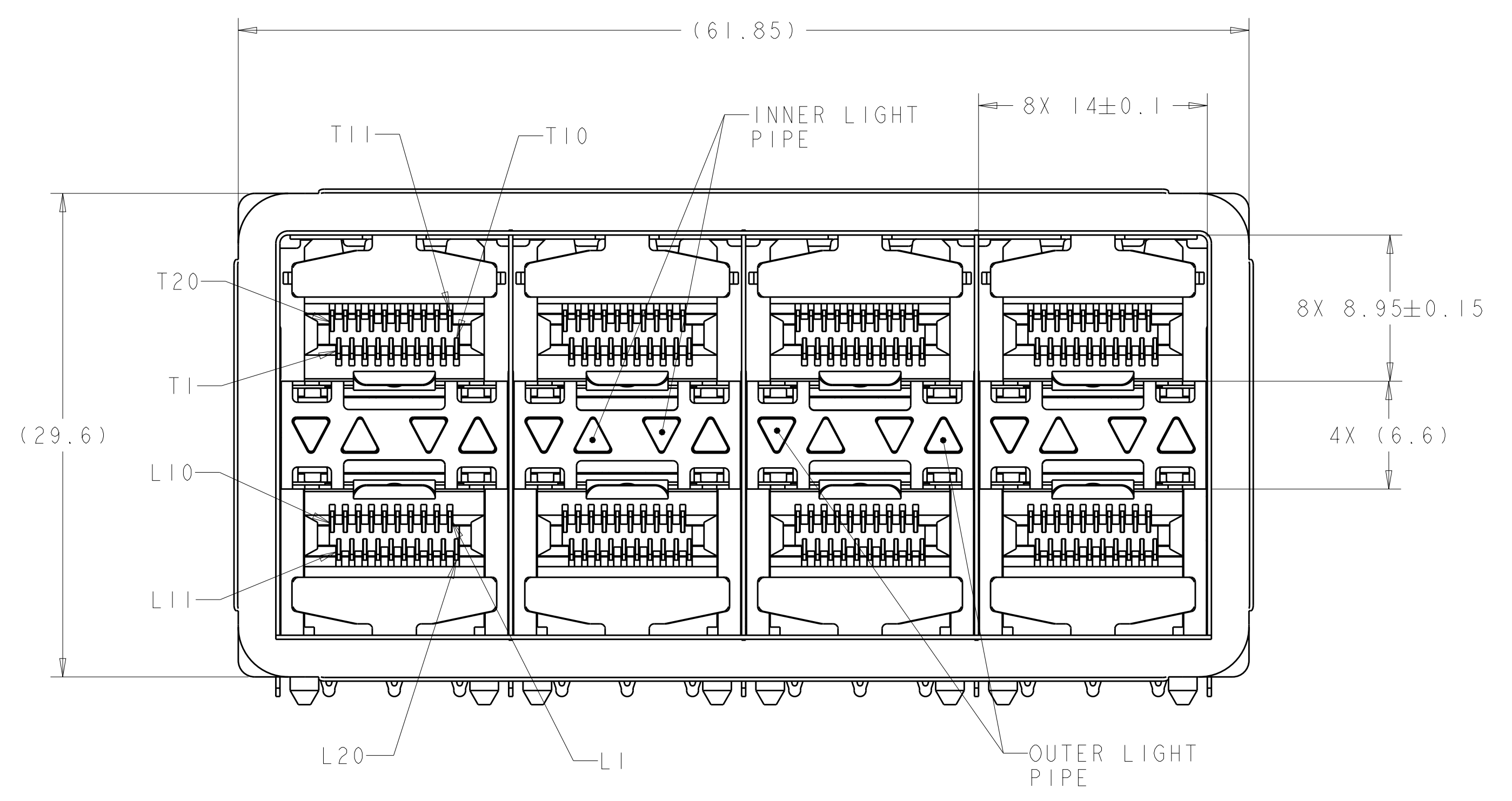

- △ MATERIALS:
 CAGE ASSEMBLY- NICKEL SILVER ALLOY PER ASTM B 122.
 BRACKET- STAINLESS STEEL.
 EMI GASKET- PLATED FILLED SILICONE.
 HOUSING- BLACK LCP, UL 94V-0 RATED.
 CHICKLET- BLACK LCP, UL 94V-0 RATED.
 LIGHT PIPE- POLYCARBONATE, CLEAR.
 INSERT - (FOR LIGHT PIPE PART NUMBERS ONLY) - LCP, BLACK, UL 94V-0
 CONTACT- COPPER ALLOY.
- △ DATUM AND BASIC DIMENSIONS ESTABLISHED BY CUSTOMER.
- 3. MINIMUM PCB THICKNESS OF 1.5.
- △ CONTACT FINISH: CONFORMS TO THE REQUIREMENTS OF TYCO ELECTRONICS PRODUCT SPECIFICATION 108-2331, BASED ON EIA/ECA-364-1000.01A, (CONTROLLED ENVIRONMENT APPLICATIONS) ON MATING INTERFACE, TIN-LEAD ON NEEDLE EYE.
- △ CONTACT FINISH: CONFORMS TO THE REQUIREMENTS OF TYCO ELECTRONICS PRODUCT SPECIFICATION 108-2331, BASED ON EIA/ECA-364-1000.01A, (CONTROLLED ENVIRONMENT APPLICATIONS) ON MATING INTERFACE, TIN ON NEEDLE EYE.
- △ FOR HOLE SIZE AND PLATINGS, SEE APPLICATION SPEC 114-13219.
- △ THE ENTIRE AREA OF THE CONNECTOR FOOTPRINT, INDICATED BY THE DASHED LINE, TO BE CONSIDERED THE KEEPOUT AREA FOR COMPONENTS AND SIGNAL TRACES, TOP SIDE ONLY. TOP SIDE TRACES ALLOWED WITHIN CONNECTOR HOLE PATTERN.
- △ LIGHT PIPE PAD LAYOUT IS FOR 0805 LOW PROFILE LED PACKAGE WITH A HEIGHT OF 0.8mm.
- △ ADDITIONAL COMPONENT LOCATED WITHIN LATCHPLATE FOR EMI SUPPRESSION.

YES	NO	SUPERSEDED	ENHANCED EMI	FINISH	DESCRIPTION	PART NUMBER
					NO LIGHT PIPES	1-2007399-8
					OUTER 2 LIGHT PIPES	1-2007399-7
					INNER 2 LIGHT PIPES	1-2007399-6
					4 LIGHT PIPES	1-2007399-5
					NO LIGHT PIPES	2007399-8
					OUTER 2 LIGHT PIPES	2007399-7
					INNER 2 LIGHT PIPES	2007399-6
					4 LIGHT PIPES	2007399-5
					NO LIGHT PIPES	2007399-4
					OUTER 2 LIGHT PIPES	2007399-3
					INNER 2 LIGHT PIPES	2007399-2
					4 LIGHT PIPES	2007399-1

THIS DRAWING IS A CONTROLLED DOCUMENT.

OWN: M. SHIRK 10OCT2007
 CHK: D. SZCZESNY 10OCT2007
 APVD: D. SZCZESNY 10OCT2007

DIMENSIONS: mm
 TOLERANCES UNLESS OTHERWISE SPECIFIED:
 0 PLC ±0.10
 1 PLC ±0.10
 2 PLC ±0.10
 3 PLC ±0.10
 4 PLC ±0.10
 ANGLES ±°

MATERIAL: FINISH:

NAME: CAGE AND PT CONNECTOR ASSEMBLY, WITH EMI GASKET, PRESS FIT, 2X4, STACKED SFP+
 PRODUCT SPEC: 108-2331
 APPLICATION SPEC: 114-13219
 SIZE: 114-13219
 WEIGHT: -
 CUSTOMER DRAWING

STE TE Connectivity

SCALE: 4:1 SHEET 1 OF 4 REV D

REVISIONS				
P.	LTN	DESCRIPTION	DATE	APVD
-	-	SEE SHEET 1	-	-

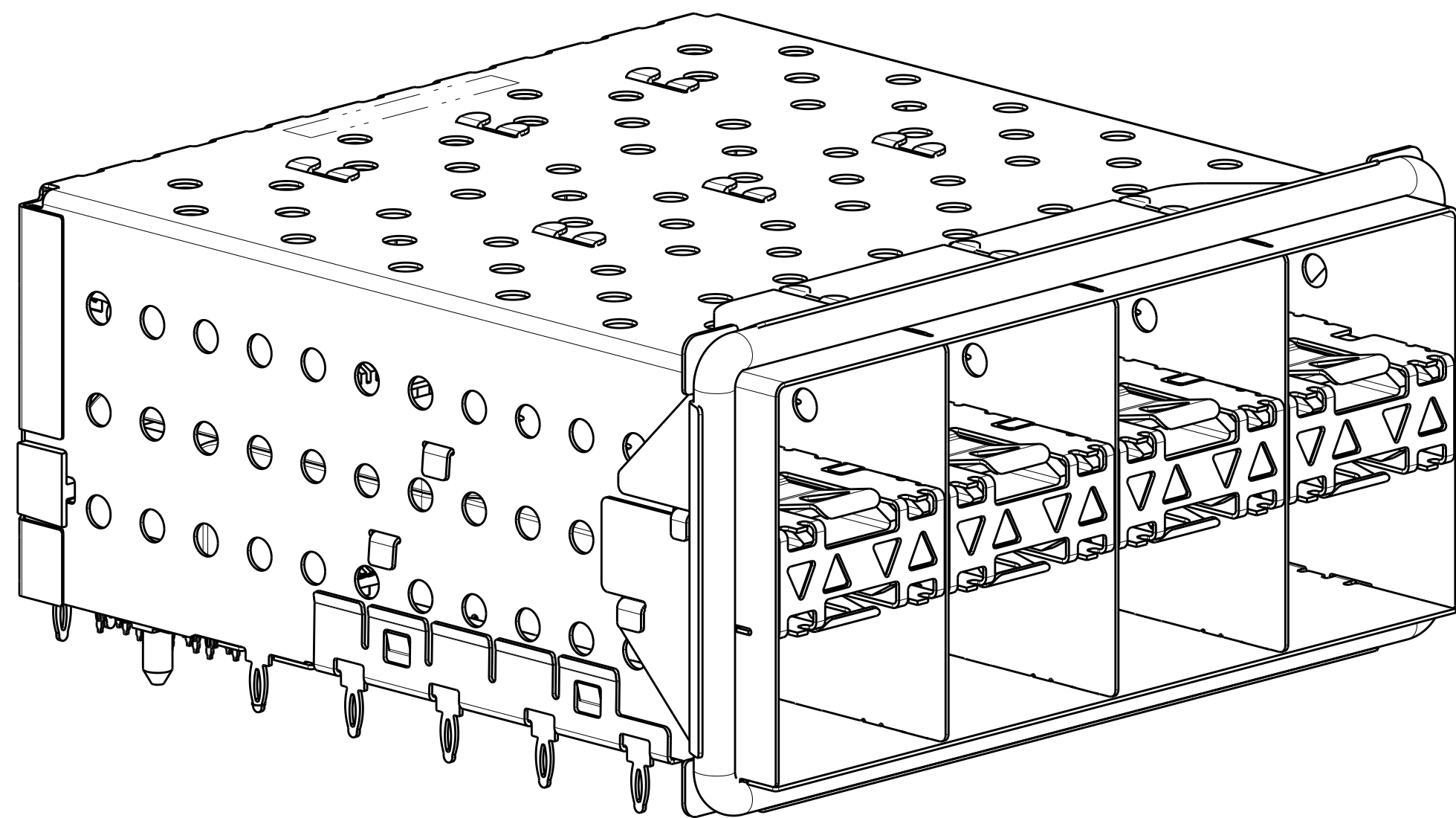

2007399-5 AND 1-2007399-5
 SCALE 3:1

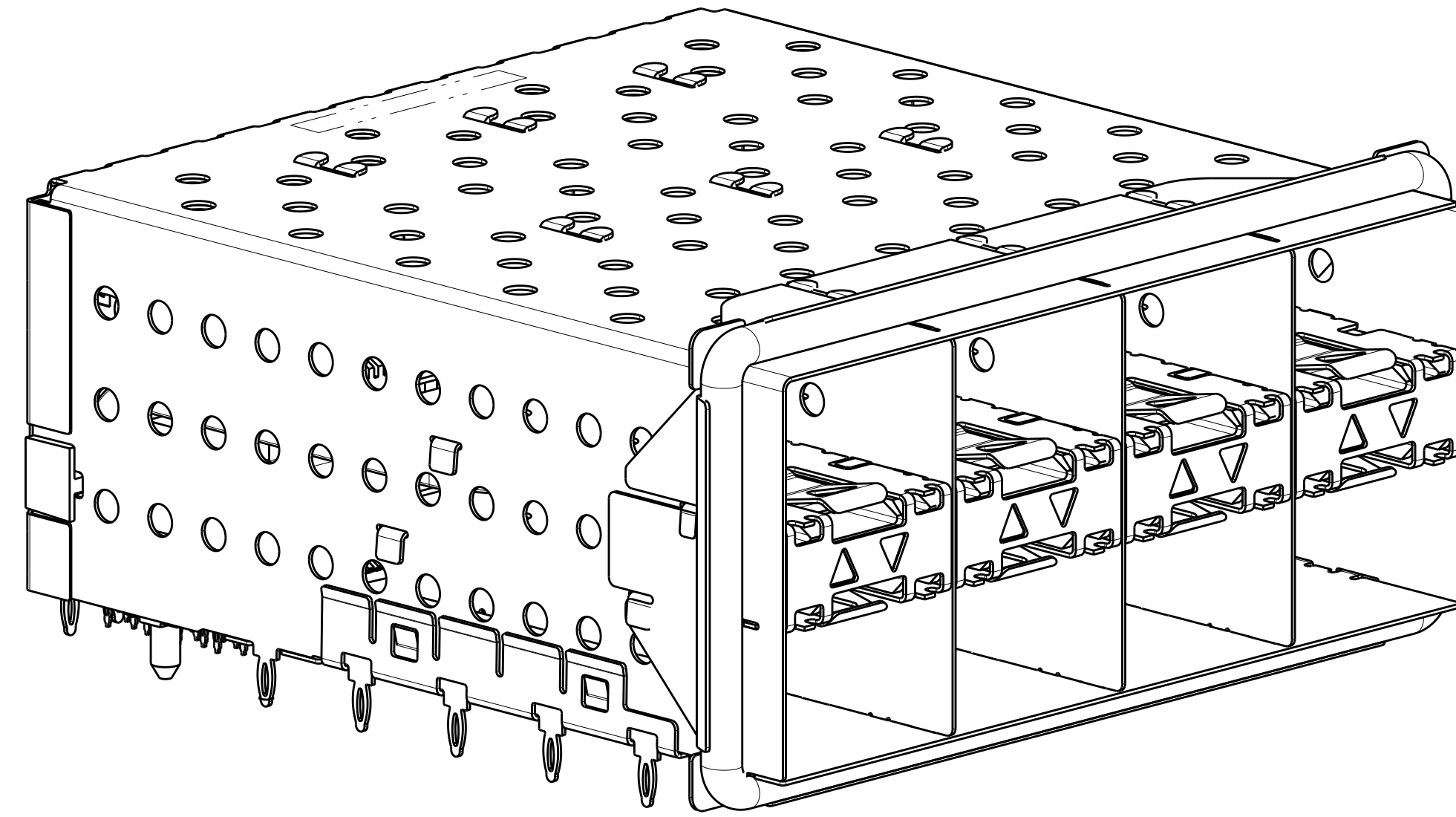

2007399-6 AND 1-2007399-6
 SCALE 3:1

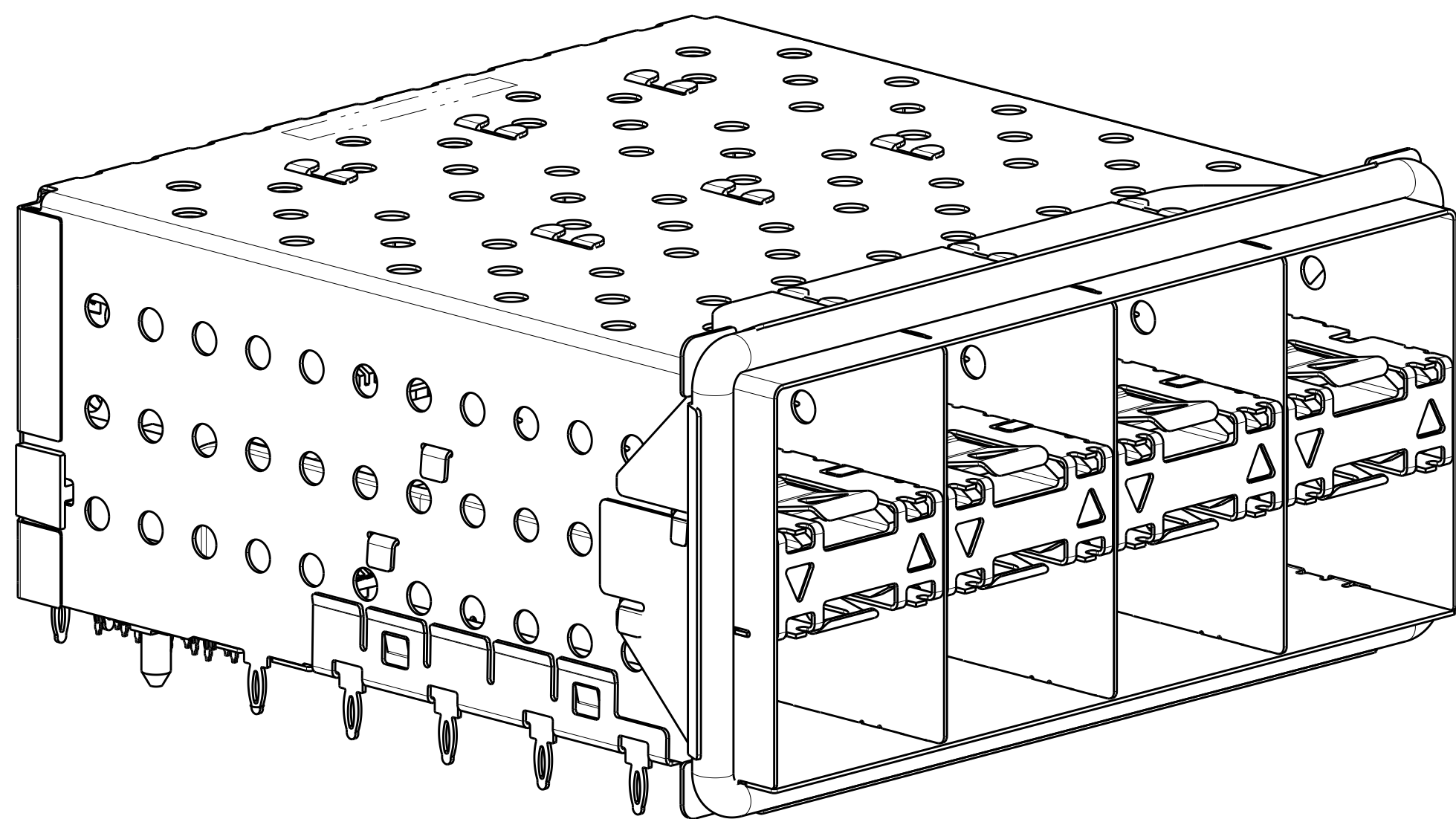

2007399-7 AND 1-2007399-7
 SCALE 3:1

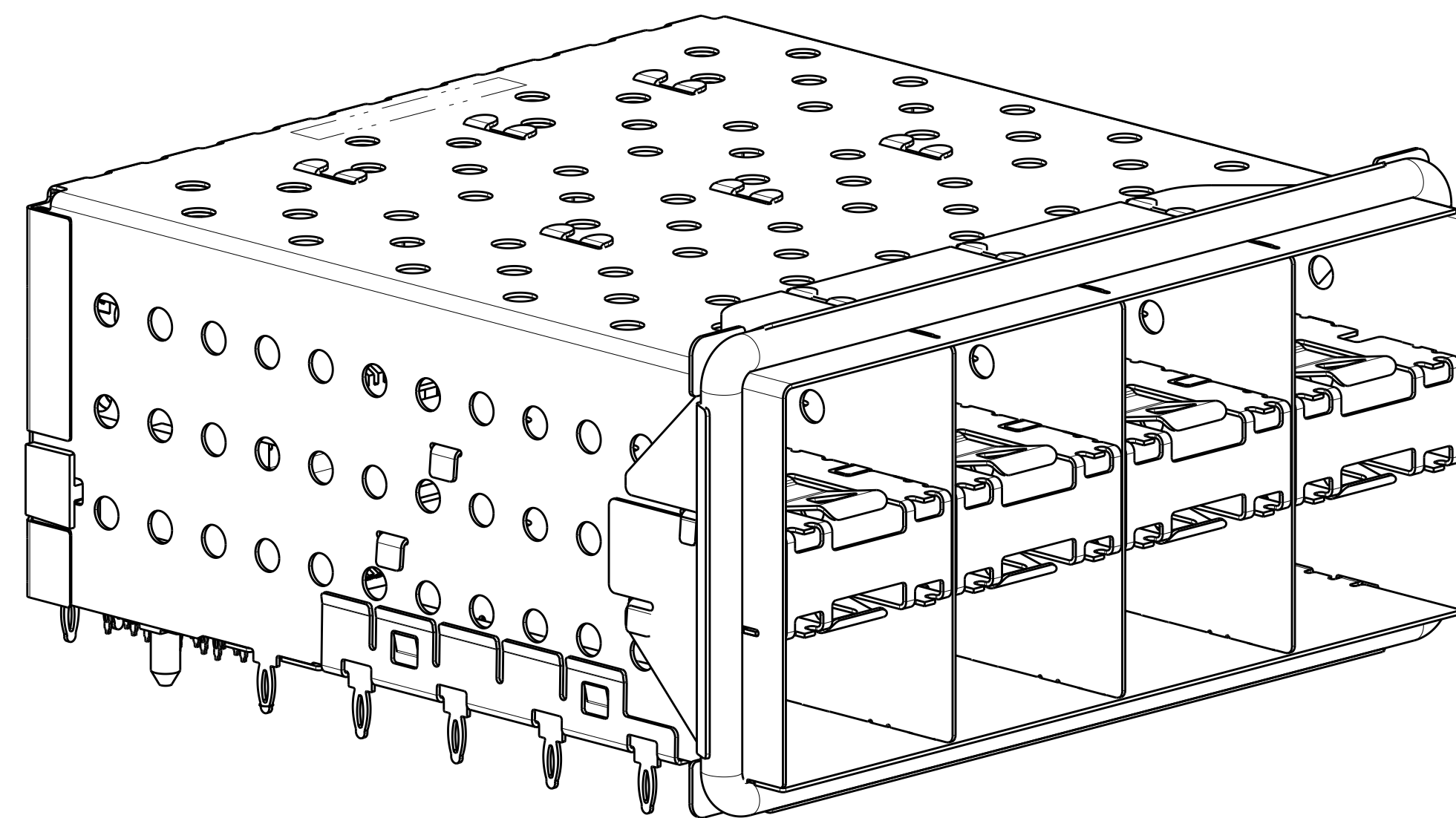

2007399-8 AND 1-2007399-8
 SCALE 3:1

THIS DRAWING IS A CONTROLLED DOCUMENT.		DWN: M. SHIRK 10OCT2007	 TE Connectivity
DIMENSIONS: mm		CHK: D. SZCZESNY 10OCT2007	
TOLERANCES UNLESS OTHERWISE SPECIFIED:		APVD: D. SZCZESNY 10OCT2007	NAME: CAGE AND PT CONNECTOR ASSEMBLY, WITH EMI GASKET, PRESS FIT, 2X4, STACKED SFP+
0 PLC ±0.10 1 PLC ±0.10 2 PLC ±0.10 3 PLC ±0.10 4 PLC ±0.10 ANGLES ±°		PRODUCT SPEC: 108-2331	
MATERIAL: FINISH:		APPLICATION SPEC: 114-13219	SIZE: A100779
		WEIGHT: -	CAGE CODE: C=2007399
		CUSTOMER DRAWING	RESTRICTED TO: -
		SCALE: 4:1	SHEET 1 OF 4 REV D

REVISIONS				
P.	LTN	DESCRIPTION	DATE	APP'D
-	-	SEE SHEET 1	-	-

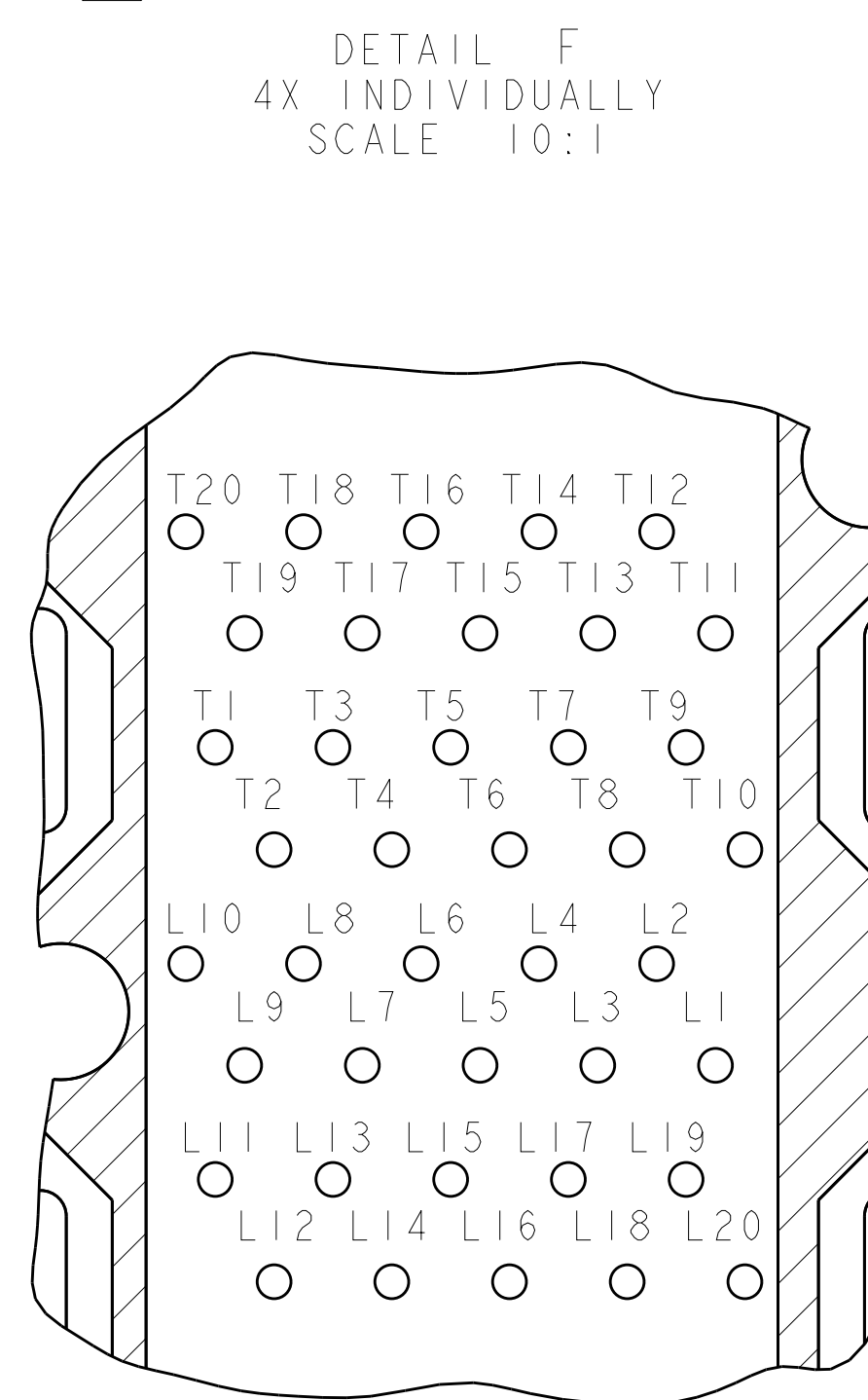
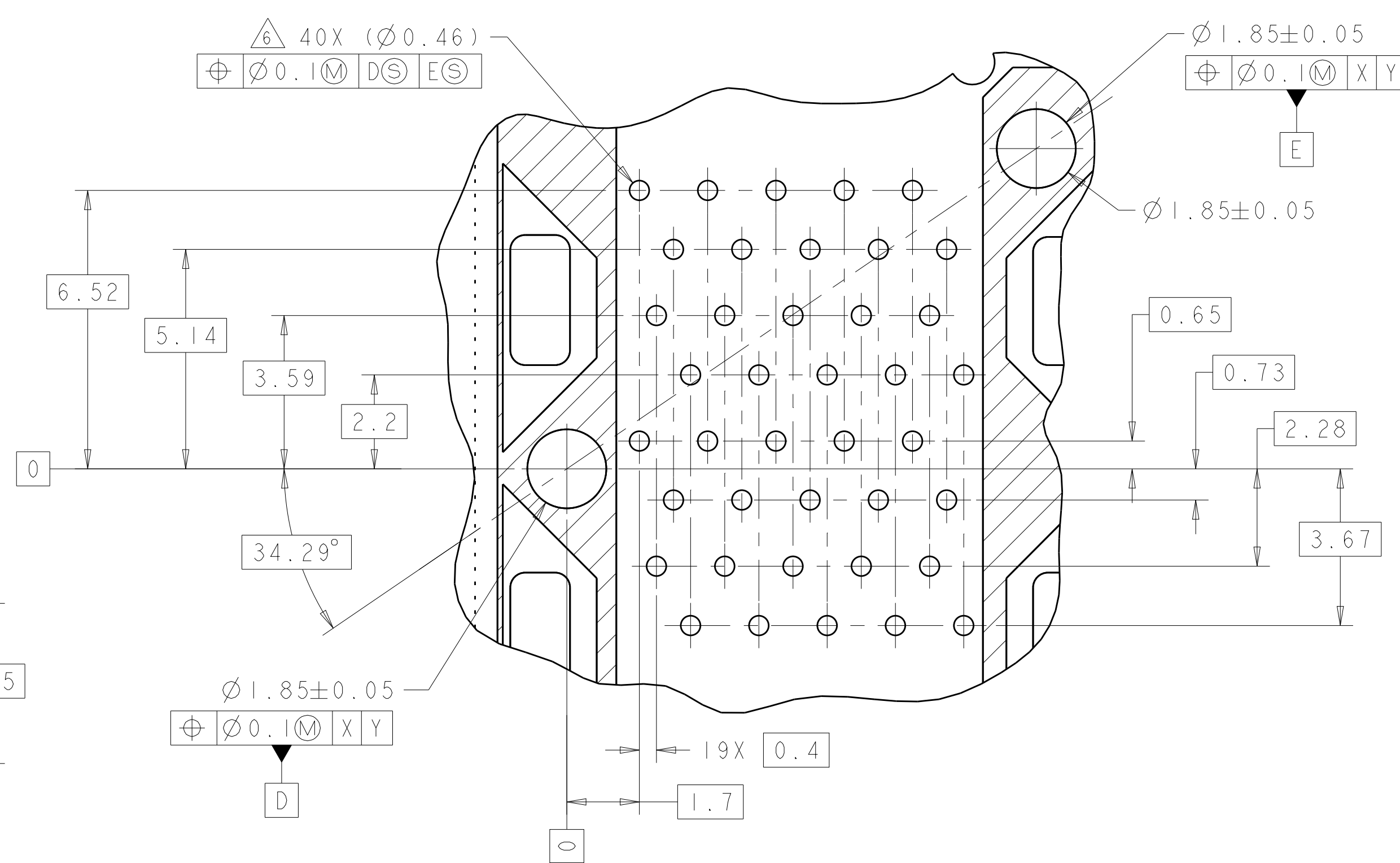
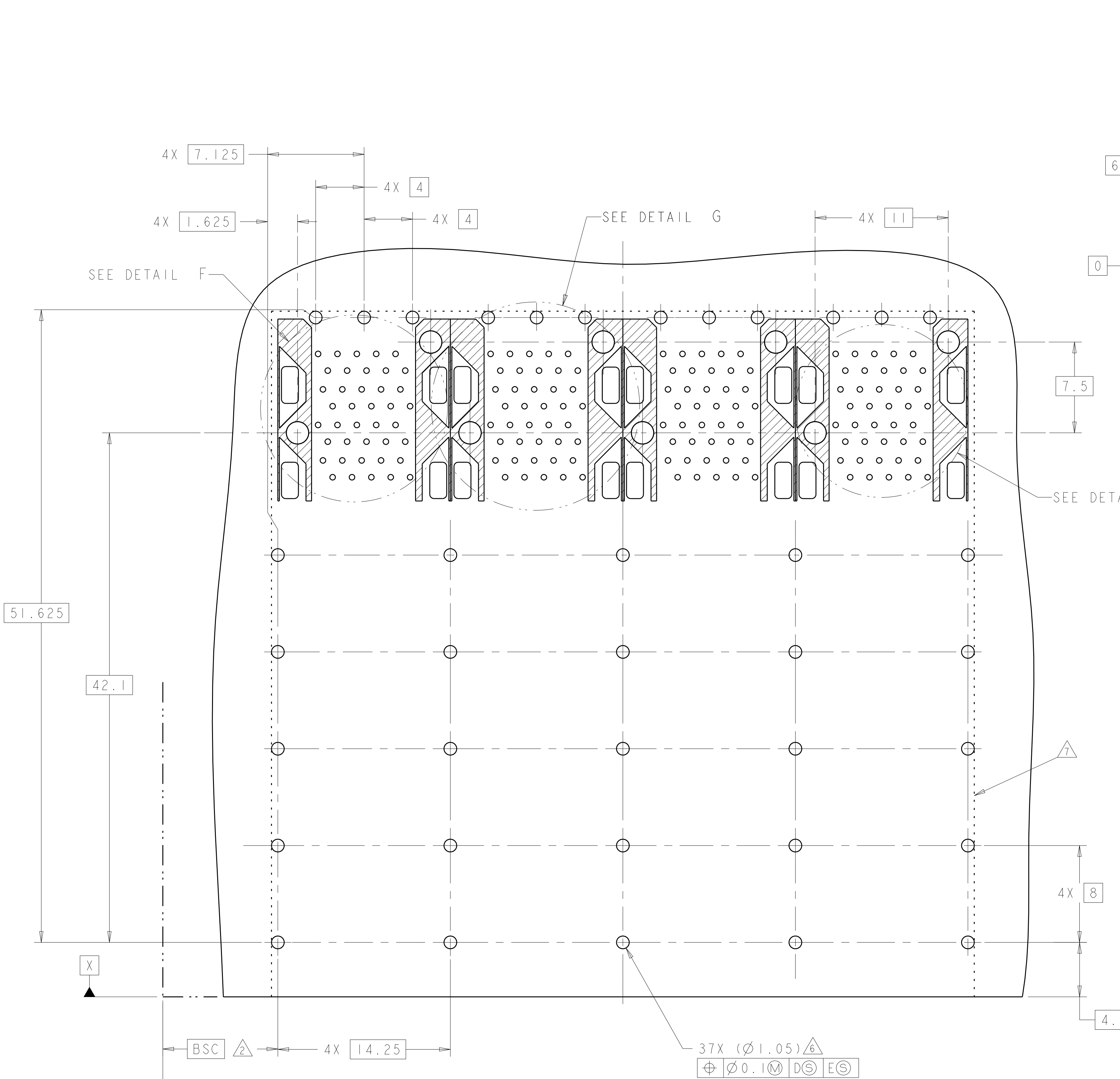

RECOMMENDED PCB LAYOUT
 COMPONENT SIDE OF BOARD
 SCALE 5:1

THIS DRAWING IS A CONTROLLED DOCUMENT.		OWN M. SHIRK	10OCT2007	TE Connectivity
DIMENSIONS:		CHK D. SZCZESNY	10OCT2007	
mm	TOLERANCES UNLESS OTHERWISE SPECIFIED:	APVD D. SZCZESNY	10OCT2007	NAME CAGE AND PT CONNECTOR ASSEMBLY, WITH EMI GASKET, PRESS FIT, 2X4, STACKED SFP+
	0 PLC ±0.10 2 PLC ±0.10 3 PLC ±0.10 4 PLC ±0.10 ANGLES ±°	PRODUCT SPEC 108-2331	APPLICATION SPEC 114-13219	SIZE A100779
MATERIAL	FINISH	WEIGHT	114-13219	RESTRICTED TO
CUSTOMER DRAWING		SCALE 4:1	SHEET 1 OF 4	REV D

REVISIONS				
P.	LTN	DESCRIPTION	DATE	APVD
-	-	SEE SHEET 1	-	-

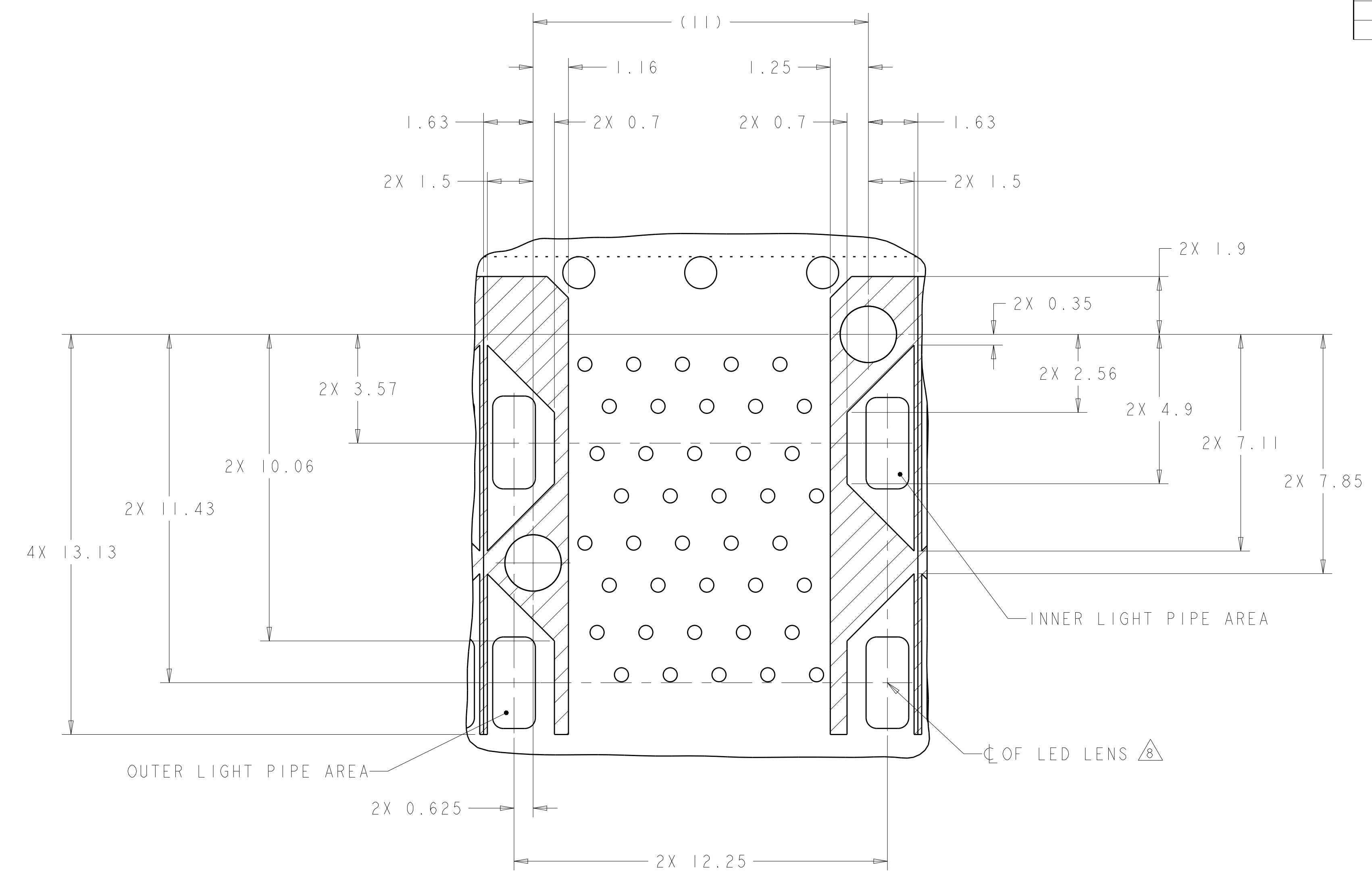

DETAIL G
 CONNECTOR HOUSING
 KEEPOUT ZONE
 4X INDIVIDUALLY
 SCALE 10:1

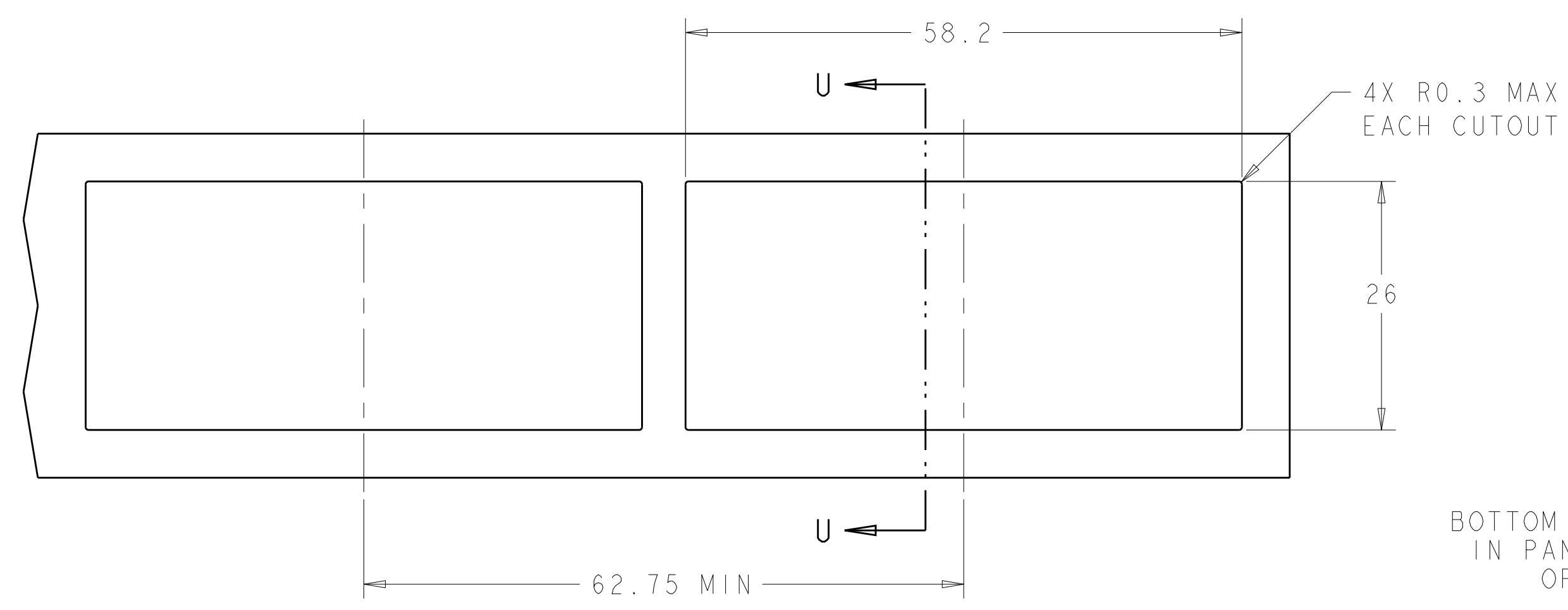

RECOMMENDED PANEL CUTOUT
 AND PC BOARD, PANEL POSITION
 SCALE 2:1

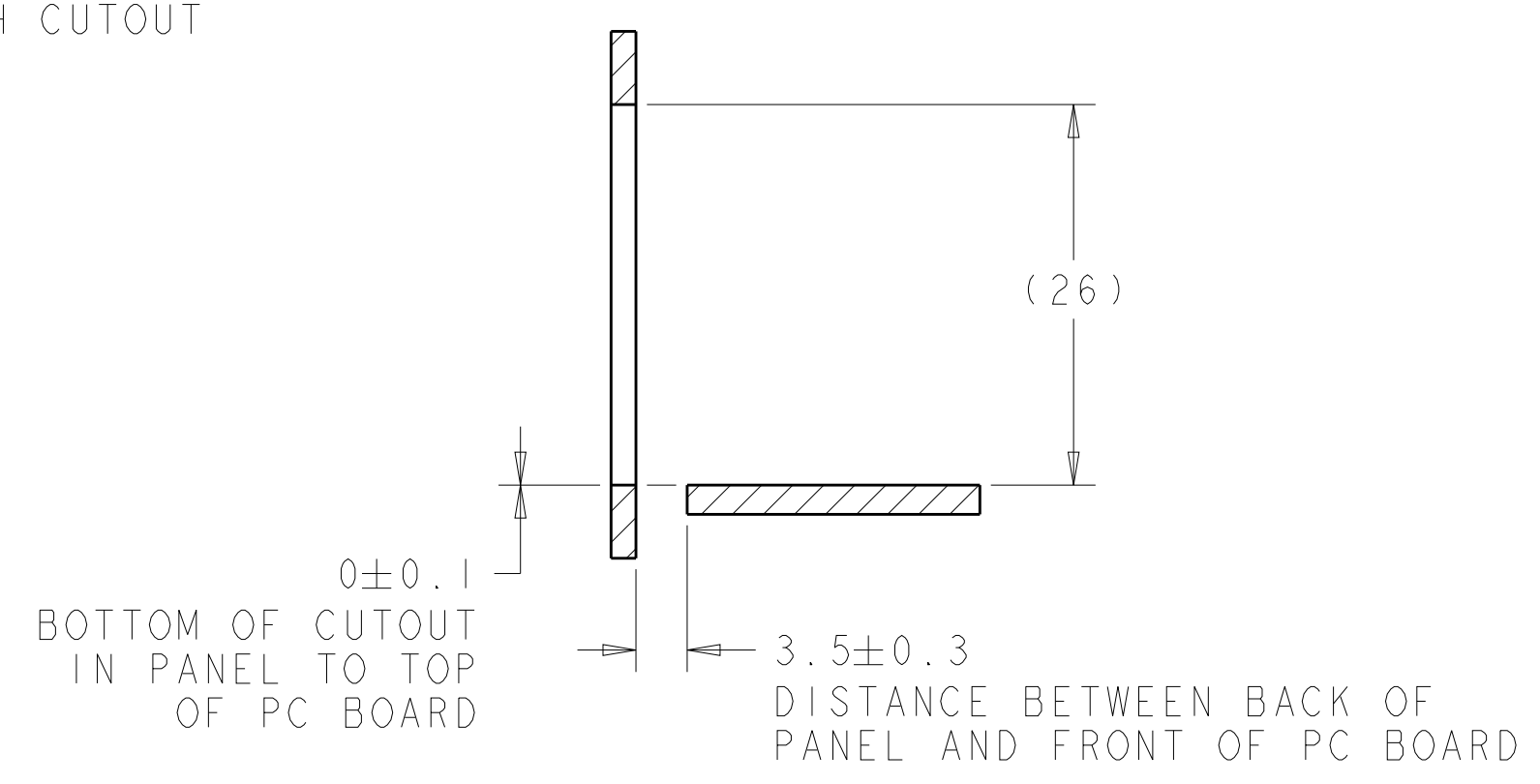

SECTION U-U

THIS DRAWING IS A CONTROLLED DOCUMENT.		DWN: M. SHIRK 10OCT2007	TE Connectivity
DIMENSIONS: mm		CHK: D. SZCZESNY 10OCT2007	
TOLERANCES UNLESS OTHERWISE SPECIFIED:		APVD: D. SZCZESNY 10OCT2007	NAME: CAGE AND PT CONNECTOR ASSEMBLY, WITH EMI GASKET, PRESS FIT, 2X4, STACKED SFP+
0 PLC ±0.10	1 PLC ±0.10	PRODUCT SPEC: 108-2331	SIZE: A100779C=2007399
2 PLC ±0.10	3 PLC ±0.10	APPLICATION SPEC: 114-13219	RESTRICTED TO: -
4 PLC ±0.10	ANGLES ±°	WEIGHT: -	SCALE: 4:1 SHEET 1 OF 4 REV D
MATERIAL: FINISH: -	CUSTOMER DRAWING		