



Chipsmall Limited consists of a professional team with an average of over 10 year of expertise in the distribution of electronic components. Based in Hongkong, we have already established firm and mutual-benefit business relationships with customers from,Europe,America and south Asia,supplying obsolete and hard-to-find components to meet their specific needs.

With the principle of “Quality Parts,Customers Priority,Honest Operation,and Considerate Service”,our business mainly focus on the distribution of electronic components. Line cards we deal with include Microchip,ALPS,ROHM,Xilinx,Pulse,ON,Everlight and Freescale. Main products comprise IC,Modules,Potentiometer,IC Socket,Relay,Connector.Our parts cover such applications as commercial,industrial, and automotives areas.

We are looking forward to setting up business relationship with you and hope to provide you with the best service and solution. Let us make a better world for our industry!



Contact us

Tel: +86-755-8981 8866 Fax: +86-755-8427 6832

Email & Skype: info@chipsmall.com Web: www.chipsmall.com

Address: A1208, Overseas Decoration Building, #122 Zhenhua RD., Futian, Shenzhen, China



SPECIFICATION CONTROL DRAWING

2018E0309

CHEMINAX

120 OHM, AWG 18, 19 STRANDS OF AWG 30,
TWINAXIAL CABLE, J1939-11 COMPLIANT

Date: 10-2-14
Revision: E

THIS SPECIFICATION SHEET FORMS A PART OF THE LATEST ISSUE OF RAYCHEM SPECIFICATION 1200.

CONSTRUCTION DETAILS

ELECTRICAL CHARACTERISTICS

DIMENSIONS ARE NOMINAL VALUES IN INCHES, UNLESS OTHERWISE DESIGNATED.

CHARACTERISTIC IMPEDANCE	120 ± 12 ohms, Method D at 1 MHz with shield grounded
MUTUAL CAPACITANCE	10.5 pF/ft. (nominal) at 1 MHz
VELOCITY OF PROPAGATION	75% (nominal)
SURFACE TRANSFER IMPEDANCE (per MIL-DTL-85485)	225 milliohms/meter (maximum) at 0.1 to 1 MHz

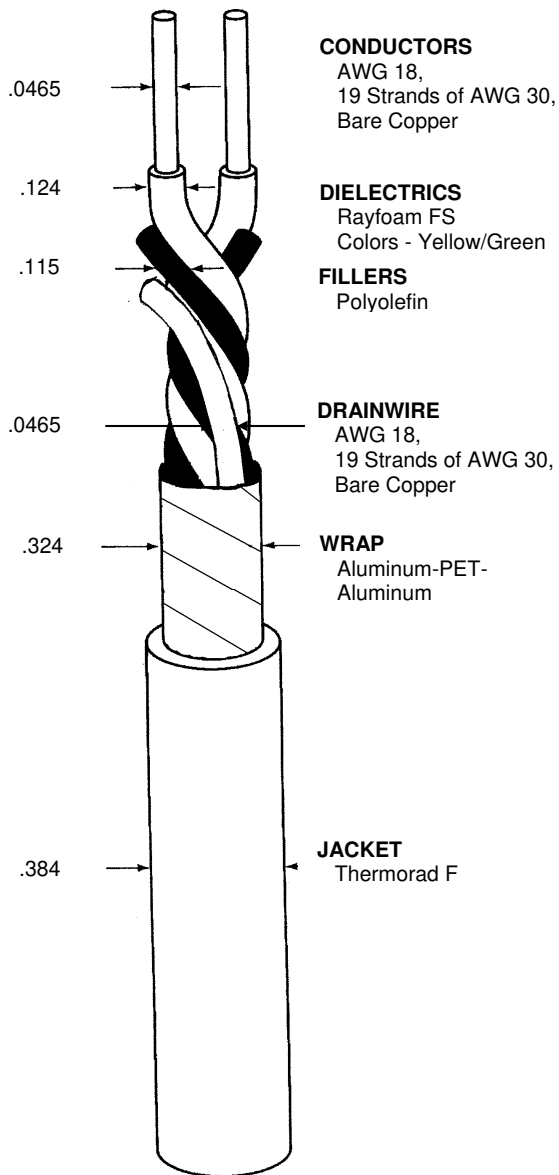

CONDUCTORS
AWG 18,
19 Strands of AWG 30,
Bare Copper

DIELECTRICS
Rayfoam FS
Colors - Yellow/Green

FILLERS
Polyolefin

DRAINWIRE
AWG 18,
19 Strands of AWG 30,
Bare Copper

WRAP
Aluminum-PET-
Aluminum

JACKET
Thermorad F

ADDITIONAL REQUIREMENTS

ELECTRICAL	
CONDUCTOR RESISTANCE (prior to cabling)	6.10 ohms/1000 ft. (nominal)
INSULATION RESISTANCE	10,000 megohms (minimum) for 1000 ft.
JACKET FLAWS	
SPARK TEST	1.0 kV (rms)
IMPULSE TEST	6.0 kV (peak)
VOLTAGE WITHSTAND (DIELECTRIC)	1500 volts (rms)
ENVIRONMENTAL	
FLAMMABILITY	Method C
HEAT SHOCK	225°C
LOW TEMPERATURE-COLD BEND	-55°C/11.0 inch mandrel
VOLTAGE WITHSTAND (Post Environmental)	1000 volts (rms), 1 minute
PHYSICAL	
INSULATION (DIELECTRIC)	
ELONGATION	100% (minimum)
TENSILE STRENGTH	1000 lbf/in ² (minimum)
JACKET	
ELONGATION	200% (minimum)
TENSILE STRENGTH	2000 lbf/in ² (minimum)
JACKET THICKNESS	.025 inch (minimum), .030 inch (nominal), .040 inch (maximum)
WRAP	.003 inch thick (nominal), 10% overlap (minimum)
CABLE IDENTIFICATION: Outer jacket shall be marked in white ink at 12 inch (nominal) intervals as follows: "RAYCHEM J1939-11 18 AWG"	

Designate outer jacket color with a dash number in accordance with MIL-STD-681. Unless otherwise specified, outer jacket color will be black designated by a "-0" appended to the part number, (e.g. 2018E0309-0).
Component Wire Stripe Option: Dielectrics striped red will be designated with a slash separating component wire colors, (e.g. 2018E0309-42/52-0).
Other codes and suffixes may be added to the part number, as necessary, to capture any additional requirements imposed by the purchase order.

WEIGHT 56.0 lbs/1000 ft. (nominal)

ENGINEERING REFERENCE

TEMPERATURE RATING 125°C (maximum)

Users should evaluate the suitability of this product for their application. Specifications are subject to change without notice. Tyco Electronics Corporation also reserves the right to make changes in materials or processing, which do not affect compliance with any specification, without notification to Buyer.

