



Chipsmall Limited consists of a professional team with an average of over 10 year of expertise in the distribution of electronic components. Based in Hongkong, we have already established firm and mutual-benefit business relationships with customers from,Europe,America and south Asia,supplying obsolete and hard-to-find components to meet their specific needs.

With the principle of “Quality Parts,Customers Priority,Honest Operation,and Considerate Service”,our business mainly focus on the distribution of electronic components. Line cards we deal with include Microchip,ALPS,ROHM,Xilinx,Pulse,ON,Everlight and Freescale. Main products comprise IC,Modules,Potentiometer,IC Socket,Relay,Connector.Our parts cover such applications as commercial,industrial, and automotives areas.

We are looking forward to setting up business relationship with you and hope to provide you with the best service and solution. Let us make a better world for our industry!



Contact us

Tel: +86-755-8981 8866 Fax: +86-755-8427 6832

Email & Skype: info@chipsmall.com Web: www.chipsmall.com

Address: A1208, Overseas Decoration Building, #122 Zhenhua RD., Futian, Shenzhen, China



THIS DRAWING IS UNPUBLISHED. RELEASED FOR PUBLICATION
 © COPYRIGHT 19 BY AMP INCORPORATED. ALL RIGHTS RESERVED.

Loc		DIST		REVISIONS			
P	LTR	DESCRIPTION		DATE	DWN	APVD	
FT	8	K		REDRAWN W/O CHANGE PER EC 0020-292-96	02 AUG 96	-	-

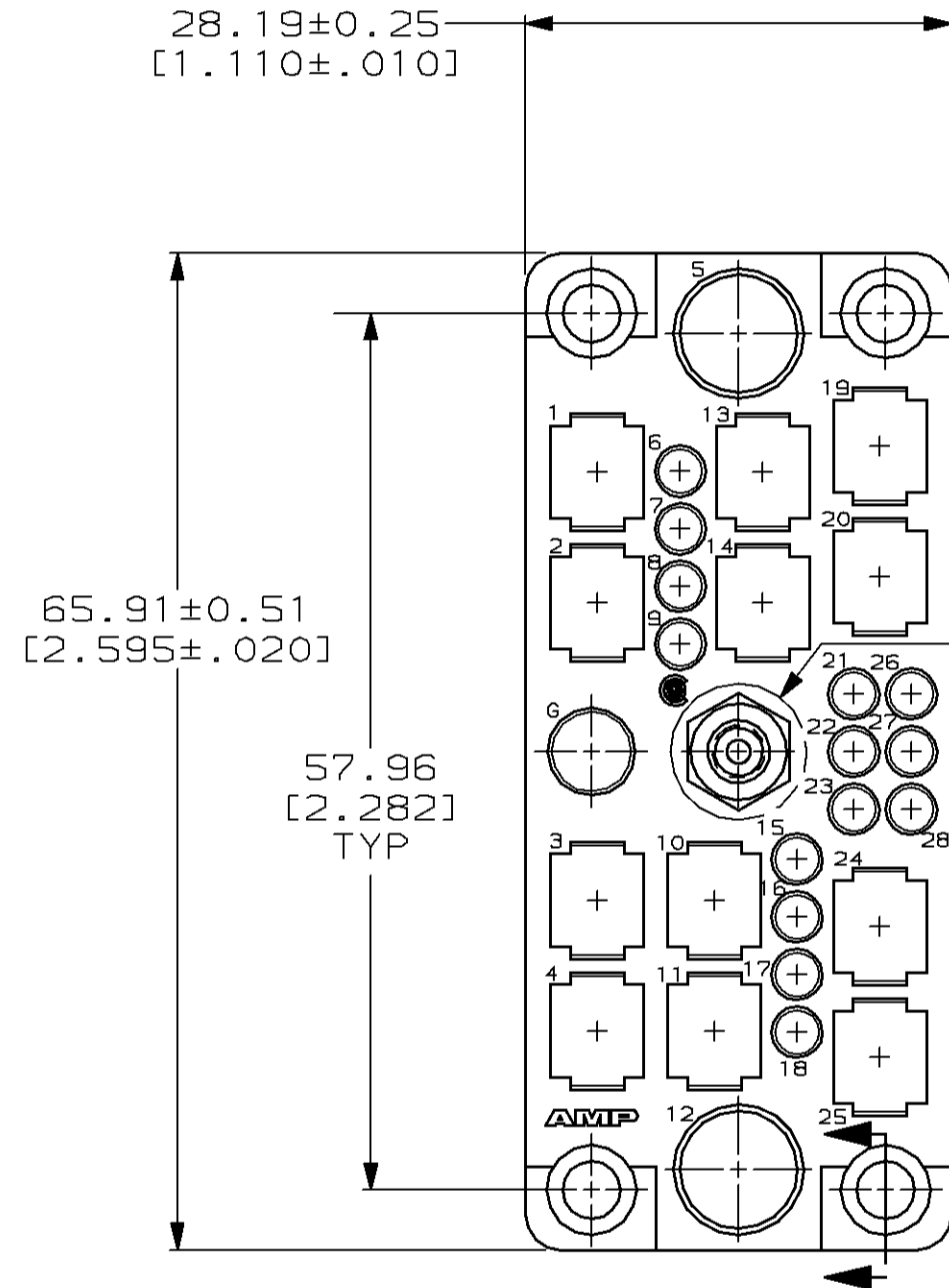
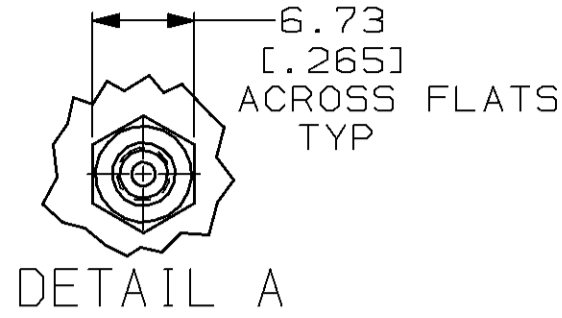

SEE
DETAIL A

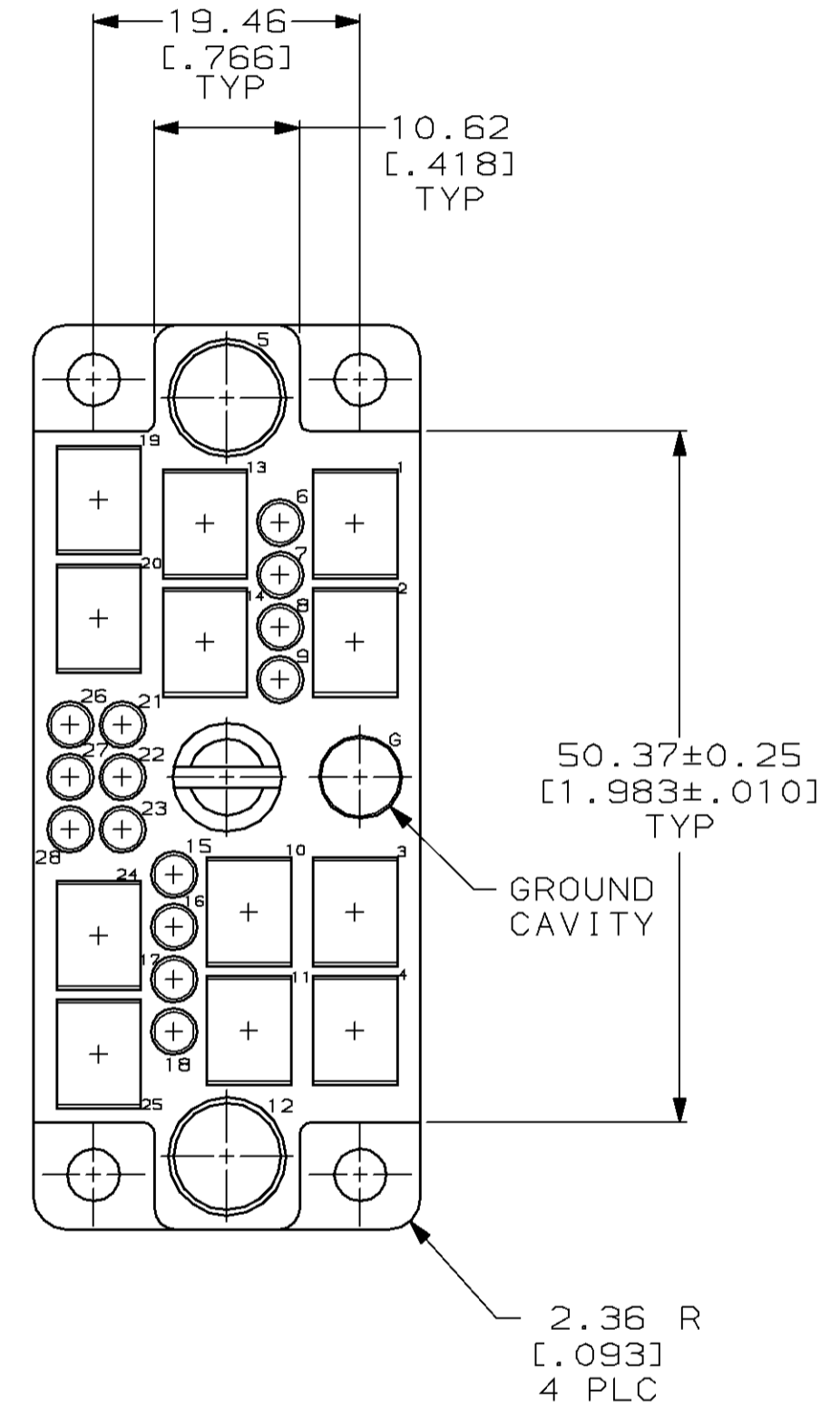
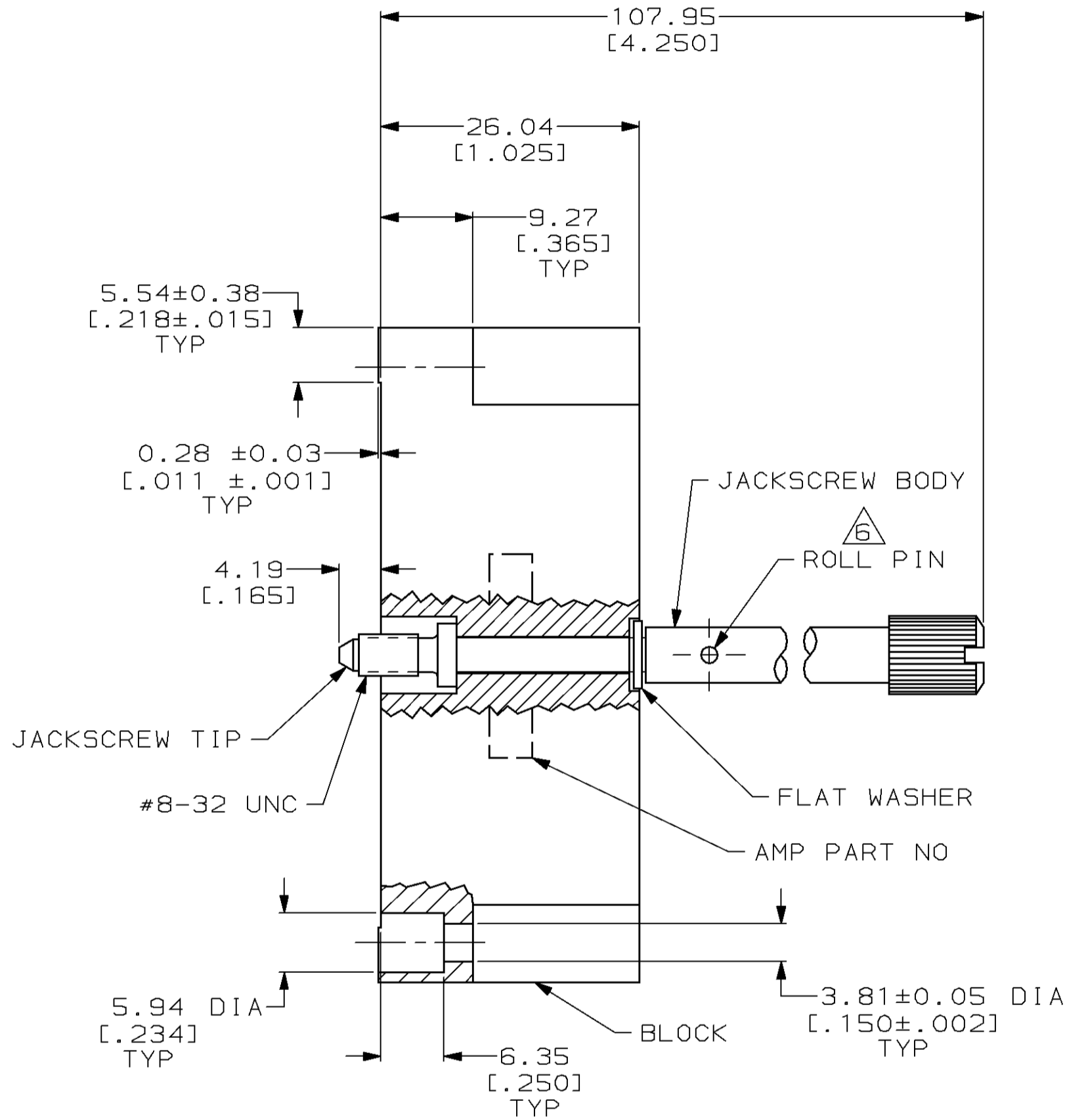

- 1 BLOCK: PHENOLIC, BLACK, PER MIL-M-14 TYPE CFG. JACKSCREW BODY: BRASS. FLAT WASHER, ROLL PIN & JACKSCREW TIP: STAINLESS STEEL.
- 2 JACKSCREW BODY: 5.08 μm [.000200] MIN ZINC PER QQ-Z-325, CLASS 3, TYPE II. FLAT WASHER & JACKSCREW TIP: PASSIVATED.
- 3 ACCOMODATES 14 TYPE II OR III #16 PIN OR SOCKET CONTACTS, 2 COAXICON PIN CONTACTS & 12 MALE POWER CONN CONTACTS.
- 4 FOR MATING RECEPT & PANEL CUTOUT SEE DWG 202478.
- 5 TYPE I #12 PIN CONTACT USED FOR GROUND.
- 6 SWAGGED AT 60° ON BOTH SIDES.

202479-2
PART NUMBER

THIS DRAWING IS A CONTROLLED DOCUMENT.		DWN B. CARBO 02 AUG 96	AMP Incorporated Harrisburg, PA 17105-3608
DIMENSIONS: mm [INCHES]		CHK R. STONE 08 AUG 96	
TOLERANCES UNLESS OTHERWISE SPECIFIED:		APVD G. STEINHAWER 22 AUG 96	NAME PLUG BLOCK ASSEMBLY, 29 POSITION, WITH CENTER FASTENER, M SERIES
0 PLC ±-		PRODUCT SPEC	
1 PLC ±-		APPLICATION SPEC	SIZE A2
2 PLC ±0.13 [.005]		WEIGHT	CAGE CODE 00779
3 PLC ±-		CUSTOMER DRAWING	DRAWING NO C-202479
4 PLC ±-		SCALE 2:1	SHEET 1 OF 1
ANGLES ±-			REV K
FINISH			