



Chipsmall Limited consists of a professional team with an average of over 10 year of expertise in the distribution of electronic components. Based in Hongkong, we have already established firm and mutual-benefit business relationships with customers from,Europe,America and south Asia,supplying obsolete and hard-to-find components to meet their specific needs.

With the principle of “Quality Parts,Customers Priority,Honest Operation,and Considerate Service”,our business mainly focus on the distribution of electronic components. Line cards we deal with include Microchip,ALPS,ROHM,Xilinx,Pulse,ON,Everlight and Freescale. Main products comprise IC,Modules,Potentiometer,IC Socket,Relay,Connector.Our parts cover such applications as commercial,industrial, and automotives areas.

We are looking forward to setting up business relationship with you and hope to provide you with the best service and solution. Let us make a better world for our industry!



Contact us

Tel: +86-755-8981 8866 Fax: +86-755-8427 6832

Email & Skype: info@chipsmall.com Web: www.chipsmall.com

Address: A1208, Overseas Decoration Building, #122 Zhenhua RD., Futian, Shenzhen, China



8

7

6

5

4

3

2

1

VICOR CONFIDENTIAL

THIS DOCUMENT AND THE DATA DISCLOSED HEREIN OR HEREWITH IS NOT TO BE REPRODUCED, USED OR DISCLOSED IN WHOLE OR IN PART TO ANYONE WITHOUT THE PERMISSION OF VICOR CORP.

REVISIONS

| REV | DESCRIPTION | DATE | APPROVED |
|-----|-----------------------|----------|----------|
| 1 | RELEASED PER E0430434 | 09/16/04 | FN |
| 2 | REVISED PER E090673C | 04/22/09 | REJH |
| 3 | REVISED PER E091595a | 09/10/09 | REJH |
| 4 | REVISED PER E101310b | 10/22/10 | AR |
| 5 | REVISED PER E111090 | 11/07/11 | REJH |

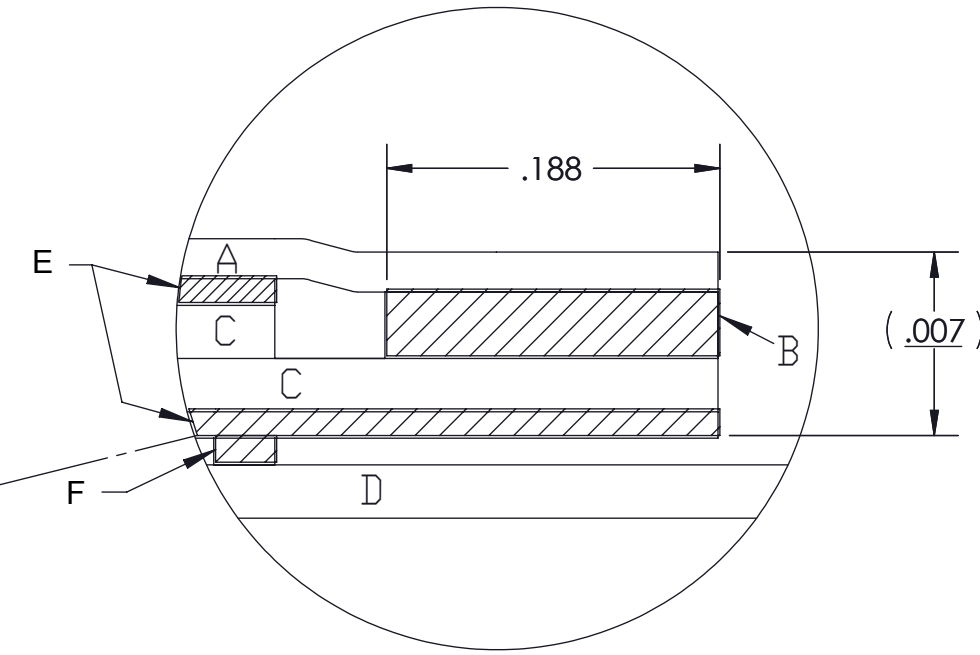
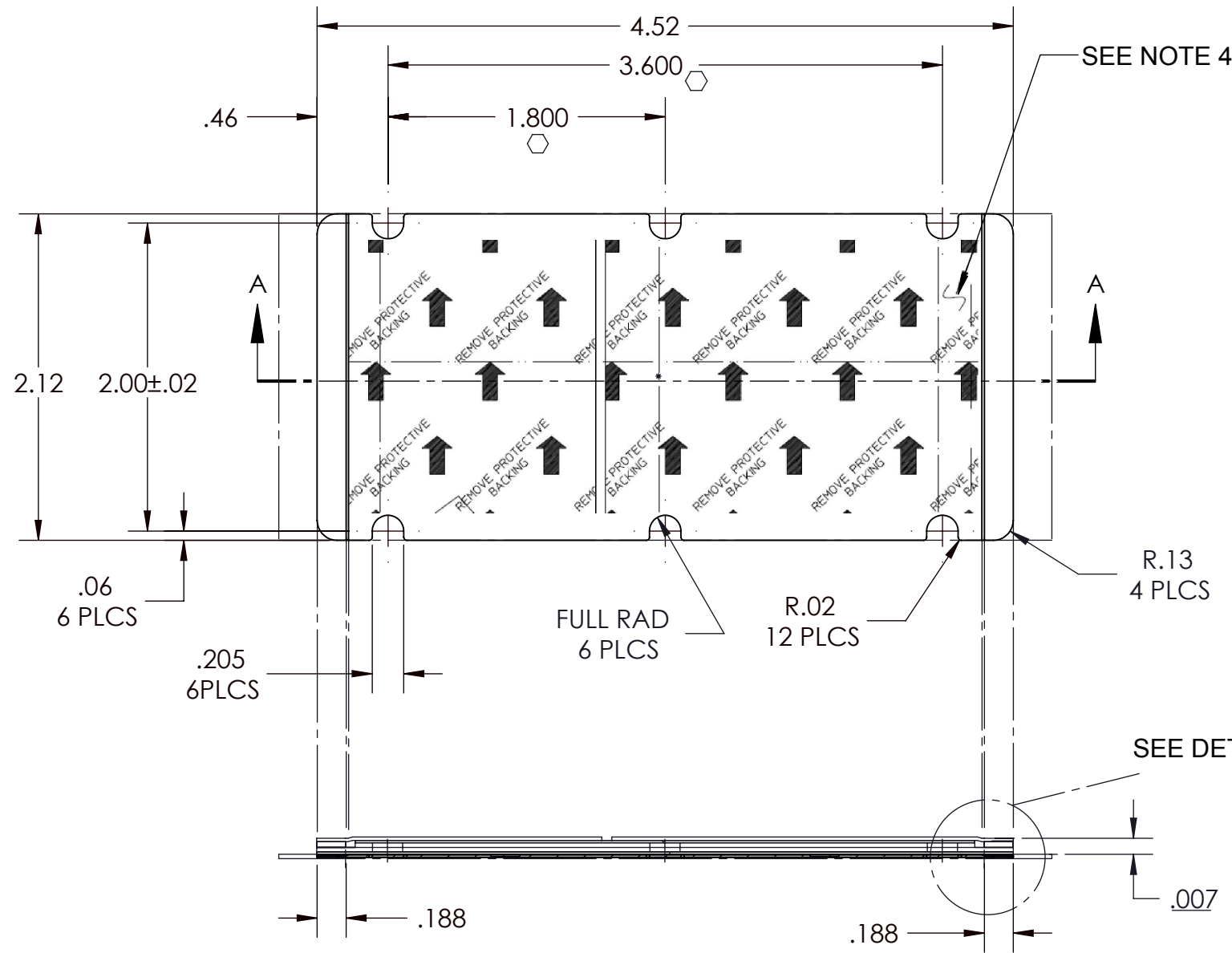

DETAIL :
 A. SPLIT RELEASE LINER.
 B. ADHESIVE STRIP; .0025 THICK .188 WIDE.
 C. ALUMINUM ALLOY 1145-0; .002 THICK.
 D. ROLL CARRIER WITH ADHESIVE STRIP BONDING.
 E. PHASE CHANGE THERMAL COMPOUND.
 F. ADHESIVE STRIPS ON ROLL CARRIER.

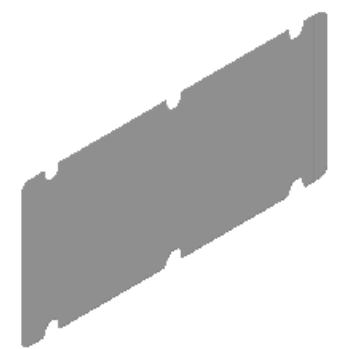

SECTION A-A
 (VERTICAL THICKNESS IS NOT SHOWN TO SCALE)

- NOTES:
1. MATERIAL: MAKE FROM HENKEL AL-2-45H-212.
 2. THICKNESS: .007±.001.
 3. SEE DETAIL FOR ASSY ORDER.
 4. FOR ARTWORK SHOWN HERE SEE DWG# 20200.
 5. ○ DENOTE CRITICAL CHARACTERISTIC FOR LOT INSPECTION.
 6. RoHS COMPLIANT PER CST-0001 LATEST REVISION.
 7. PRIOR TO ASSEMBLY, PRODUCTS SHALL BE STORED IN A COOL, DRY LOCATION IN ORIGINAL PACKAGING AT TEMPERATURES BELOW 40°C (104°F). UNDER THESE CONDITIONS THE SHELF LIFE IS INDEFINITE. THERMMATE PADS CAN BE PRE-APPLIED TO BASEPLATES OR HEAT SINKS WHICH ARE THEN SHIPPED TO A FINAL ASSEMBLY LOCATION, AS LONG AS THE TEMPERATURE DOES NOT EXCEED THE LEVEL INDICATED ABOVE.

| | | | | |
|------------|---|--|----------|--|
| DRAWN | DATE | | | |
| J. RENAUD | 2/13/97 | | | |
| MATERIAL | UNLESS OTHERWISE SPECIFIED DIMENSIONS ARE INCH [MM] TOLERANCES ARE: DECIMALS ANGLES X.XX [X.X] = ±0.01 [0.25] ±1° X.XXX [X.XX] = ±0.005 [0.127] | THERMAL INTERFACE PAD THERMATE (MAXI) P/N 20263 | | |
| FINISH | THIRD ANGLE PROJECTION DO NOT SCALE DRAWING | | | |
| SIZE | CAGE CODE | DWG NO | REV | |
| B | 67131 | 16188 | 5 | |
| SCALE 1: 1 | | SHEET 1 OF 1 | | |

8

7

6

5

4

3

2

1