



Chipsmall Limited consists of a professional team with an average of over 10 year of expertise in the distribution of electronic components. Based in Hongkong, we have already established firm and mutual-benefit business relationships with customers from,Europe,America and south Asia,supplying obsolete and hard-to-find components to meet their specific needs.

With the principle of “Quality Parts,Customers Priority,Honest Operation,and Considerate Service”,our business mainly focus on the distribution of electronic components. Line cards we deal with include Microchip,ALPS,ROHM,Xilinx,Pulse,ON,Everlight and Freescale. Main products comprise IC,Modules,Potentiometer,IC Socket,Relay,Connector.Our parts cover such applications as commercial,industrial, and automotives areas.

We are looking forward to setting up business relationship with you and hope to provide you with the best service and solution. Let us make a better world for our industry!



## Contact us

Tel: +86-755-8981 8866 Fax: +86-755-8427 6832

Email & Skype: info@chipsmall.com Web: www.chipsmall.com

Address: A1208, Overseas Decoration Building, #122 Zhenhua RD., Futian, Shenzhen, China



THIS DRAWING IS UNPUBLISHED. RELEASED FOR PUBLICATION AUG 2006  
 © COPYRIGHT 2009 BY TYCO ELECTRONICS CORPORATION. ALL RIGHTS RESERVED.

LOC	DIST	REVISIONS			
P	LTR	DESCRIPTION	DATE	DWN	APVD
	B	RELEASED(ECR-15-013804)	3MAR2016	A.X	H.W

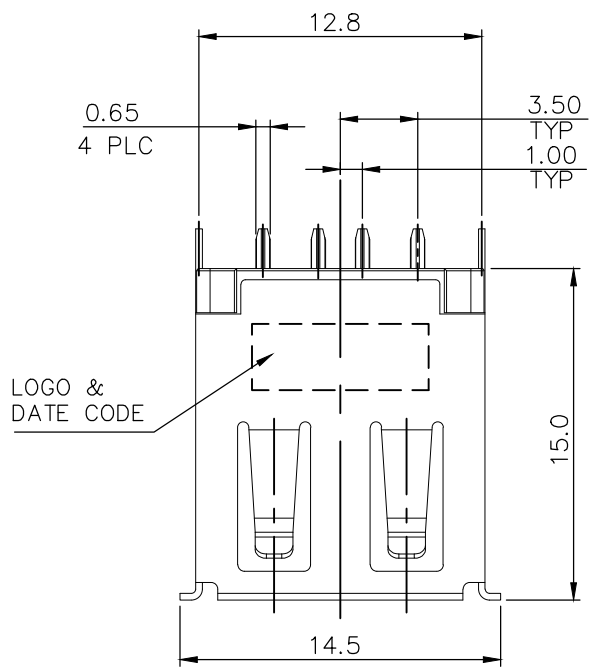

NOTE:  
 1. MATERIAL:  
 HOUSING: THERMOPLASTIC(PA9T) WITH 30%GF, UL 94V-0, BLACK COLOR.  
 CAP: THERMOPLASTIC(PA9T) WITH 30%GF, UL 94V-0, WHITE COLOR.  
 CONTACT: PHOSPHOR BRONZE.  
 SHELL: BARSS.  
 2. FINISH:  
 CONTACT: GOLD FLASH PLATING ON CONTACT AREA, 3.048 μm [120 μ"] MIN. MATTE TIN PLATING ON SOLDER TAILS. 1.27 μm [50 μ"] MIN. NICKEL UNDERPLATING OVER ALL.  
 SHELL: 0.762 μm [30 μ"] MIN. NICKEL PLATED OVER 0.762 μm [30 μ"] MIN. Cu UNDERPLATING OVER ALL.  
 3. REFLOW SOLDER CAPABLE TO 260°C PER TE SPEC 109-201, CONDITION B.

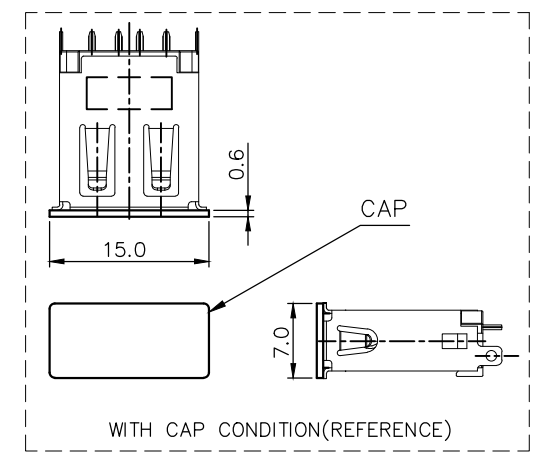
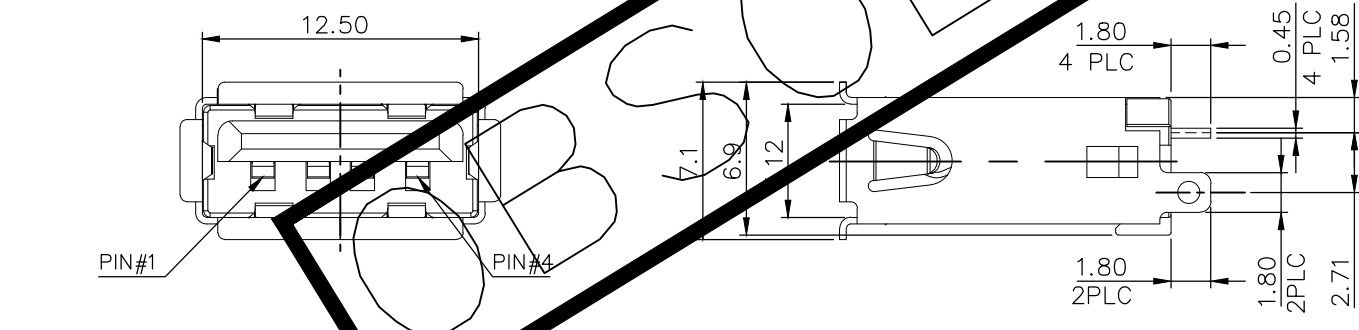
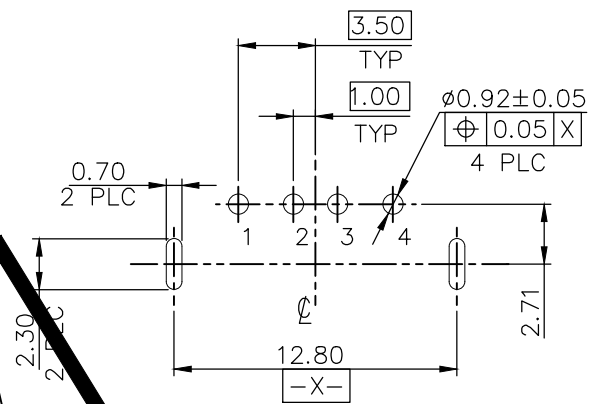

TAPE & REEL	2041230-1
PACKAGE	PART NUMBER

THIS DRAWING IS A CONTROLLED DOCUMENT.		DWN S. CHIEN 25FEB2010	Tyco Electronics Corporation Taipei, Taiwan																		
DIMENSIONS: MM		CHK S. CHIEN 25FEB2010																			
TOLERANCES UNLESS OTHERWISE SPECIFIED:		APVD W. KODAMA 25FEB2010	NAME																		
<table border="1"> <tr><td>0 PLC</td><td>±</td><td>-</td></tr> <tr><td>1 PLC</td><td>±</td><td>0.30</td></tr> <tr><td>2 PLC</td><td>±</td><td>0.20</td></tr> <tr><td>3 PLC</td><td>±</td><td>0.15</td></tr> <tr><td>4 PLC</td><td>±</td><td>-</td></tr> <tr><td>ANGLES</td><td>±</td><td>3°</td></tr> </table>		0 PLC	±	-	1 PLC	±	0.30	2 PLC	±	0.20	3 PLC	±	0.15	4 PLC	±	-	ANGLES	±	3°	PRODUCT SPEC 108-57797	USB CONNECTOR, A SERIES, VERTICAL, DIP TYPE
0 PLC	±	-																			
1 PLC	±	0.30																			
2 PLC	±	0.20																			
3 PLC	±	0.15																			
4 PLC	±	-																			
ANGLES	±	3°																			
MATERIAL SEE NOTE		APPLICATION SPEC	SIZE A3																		
FINISH SEE NOTE		WEIGHT 2.02 GRAMS	CAGE CODE 00779																		
		CUSTOMER DRAWING	DRAWING NO C=2041230																		
		SCALE	RESTRICTED TO																		
		SHEET 1 OF 1	REV B																		