



Chipsmall Limited consists of a professional team with an average of over 10 year of expertise in the distribution of electronic components. Based in Hongkong, we have already established firm and mutual-benefit business relationships with customers from,Europe,America and south Asia,supplying obsolete and hard-to-find components to meet their specific needs.

With the principle of “Quality Parts,Customers Priority,Honest Operation,and Considerate Service”,our business mainly focus on the distribution of electronic components. Line cards we deal with include Microchip,ALPS,ROHM,Xilinx,Pulse,ON,Everlight and Freescale. Main products comprise IC,Modules,Potentiometer,IC Socket,Relay,Connector.Our parts cover such applications as commercial,industrial, and automotives areas.

We are looking forward to setting up business relationship with you and hope to provide you with the best service and solution. Let us make a better world for our industry!



## Contact us

Tel: +86-755-8981 8866 Fax: +86-755-8427 6832

Email & Skype: info@chipsmall.com Web: www.chipsmall.com

Address: A1208, Overseas Decoration Building, #122 Zhenhua RD., Futian, Shenzhen, China



LOC		DIST		REVISIONS			
P	LTR	DESCRIPTION	DATE	DWN	APVD		
N		REV PER ECO-08-019991	22OCT08	PK	BW		

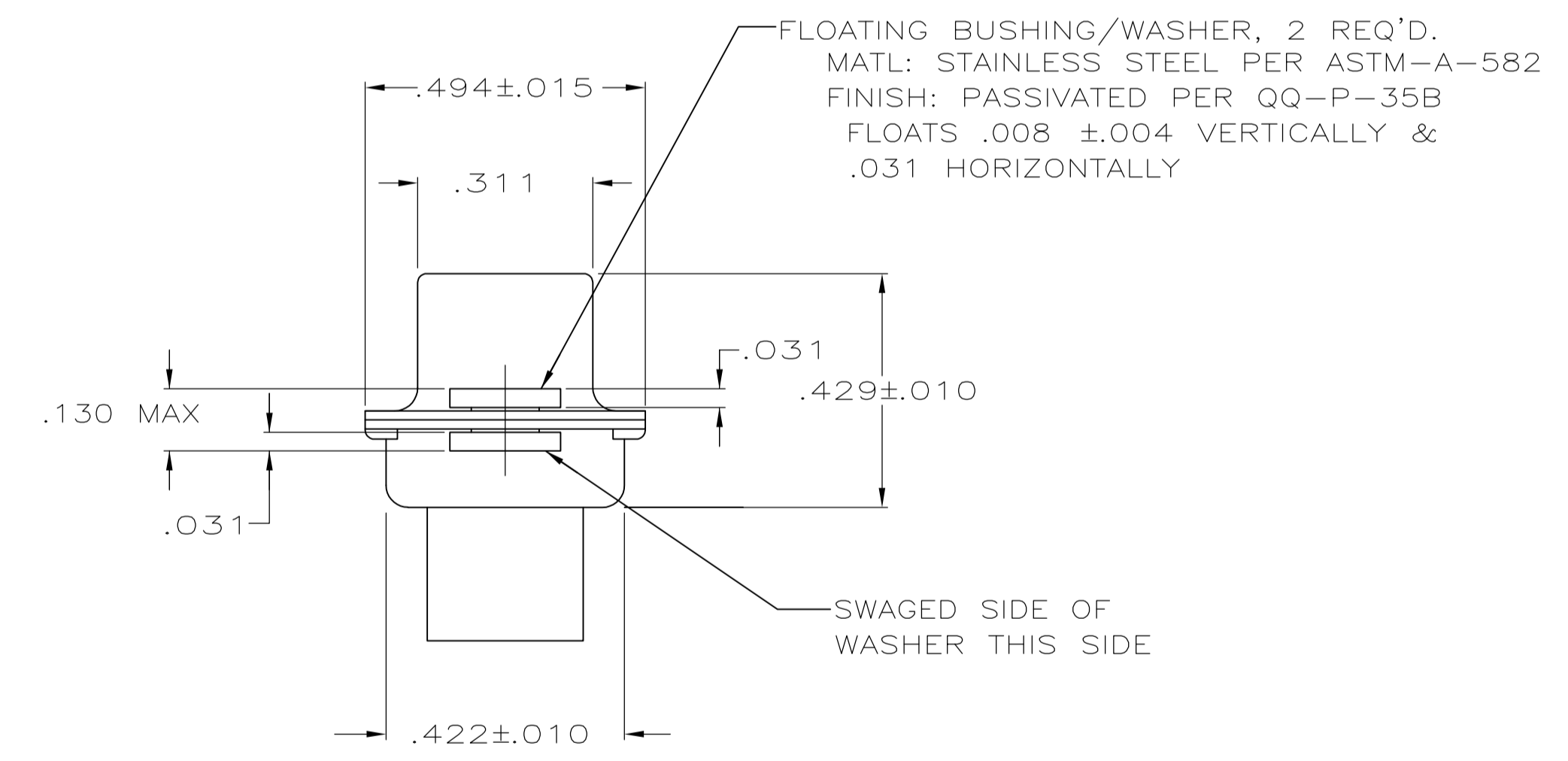
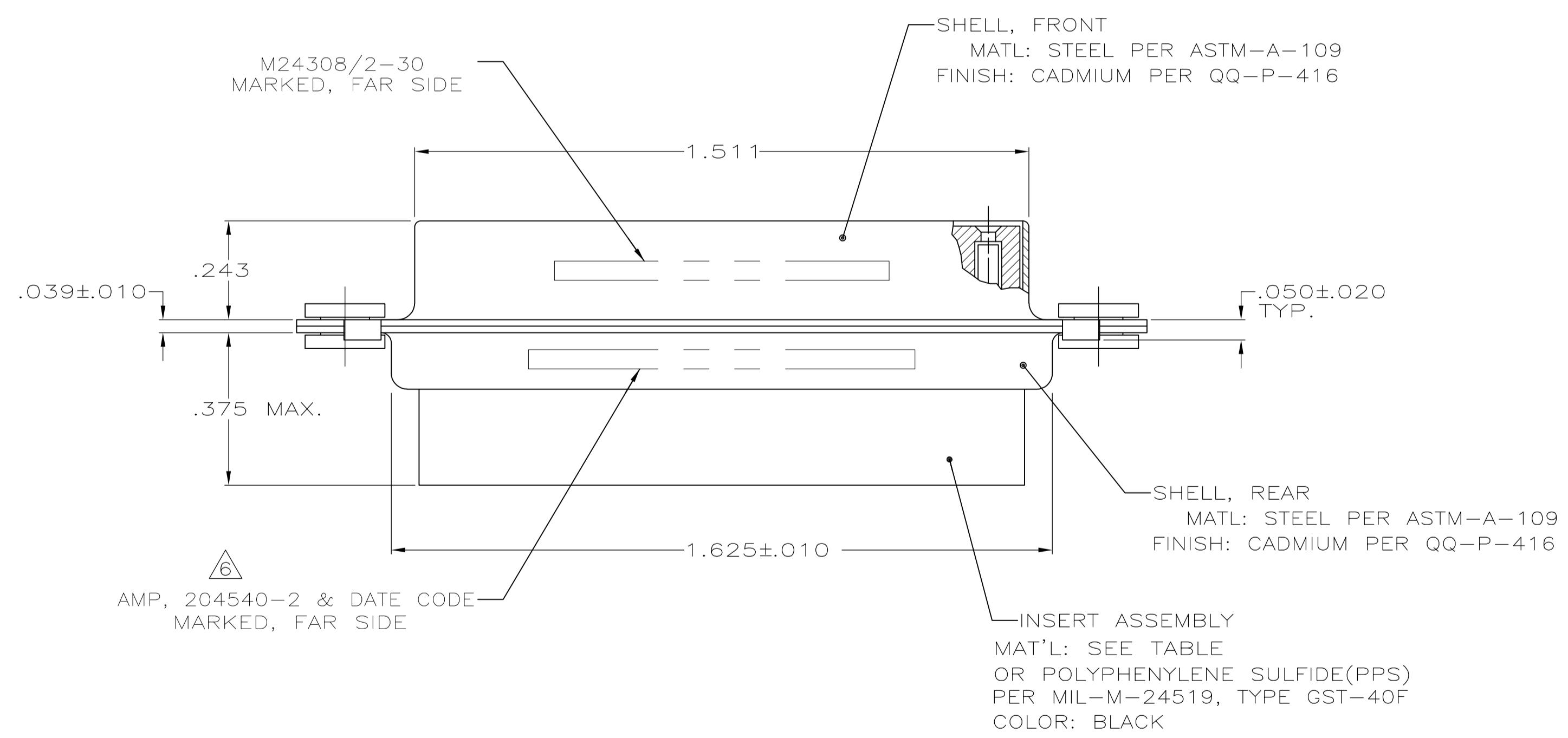
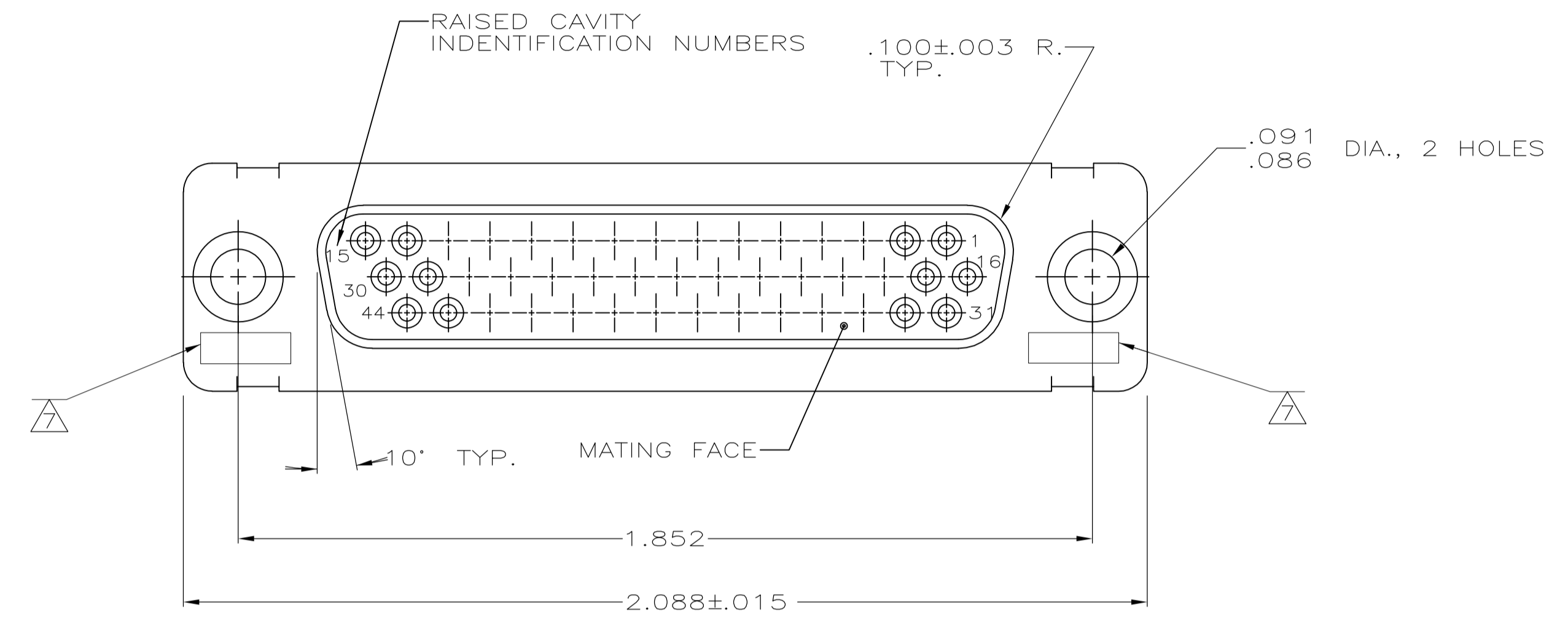

1. THIS RCPT. IS DESIGNED TO CONFORM TO THE LATEST ISSUE OF MIL-C-24308
  2. MAX WIRE INSUL TO BE USED WITH THIS RCPT IS .054 DIA
  3. METAL RETENTION CLIPS ARE INCLUDED IN INSERTS
  4. PACKAGE MARKED M 24308/2-299F
  5. THIS RCPT. WILL ACCEPT SIZE 22 SOCKET CONTACT M 24308/12 OR AMP # 204351
- △ AMP PART NO. MARKED ON CONNECTOR REPRESENTS KIT NUMBER WITH CONTACTS
- △ UL/CSA DESIGNATION MARKED IN THIS AREA, OPTIONAL

OBSELETE	PHENOLIC, COLOR: BLACK	204528-2
	POLYPHENYLENE SULFIDE (PPS) GST-40F PER MIL-M-24519 OR CLASS FILLED POLYESTER TPES013G30 PER ASTM D5927 COLOR, BLACK	204528-1
	INSERT MATERIAL	PART NO.

THIS DRAWING IS A CONTROLLED DOCUMENT.

DIMENSIONS: INCHES	TOLERANCES UNLESS OTHERWISE SPECIFIED:	DWN: C.C.THOMAS 12-3-87	CHK: F.C.BALLEW 1-25-88	APVD: DJM 1-25-88	NAME: Tyco Electronics Corporation Harrisburg, PA 17105-3608
0 PLC ± -	1 PLC ± -	2 PLC ± -	3 PLC ± .005	4 PLC ± -	ANGLES ± -
MATERIAL: SEE CALLOUTS	FINISH: SEE CALLOUTS	WEIGHT: -	SIZE: A1	CAGE CODE: 00779	DRAWING NO: 204528
CUSTOMER DRAWING			SCALE: 4:1	SHEET: 1 OF 1	REV: N