



Chipsmall Limited consists of a professional team with an average of over 10 year of expertise in the distribution of electronic components. Based in Hongkong, we have already established firm and mutual-benefit business relationships with customers from,Europe,America and south Asia,supplying obsolete and hard-to-find components to meet their specific needs.

With the principle of "Quality Parts,Customers Priority,Honest Operation,and Considerate Service",our business mainly focus on the distribution of electronic components. Line cards we deal with include Microchip,ALPS,ROHM,Xilinx,Pulse,ON,Everlight and Freescale. Main products comprise IC,Modules,Potentiometer,IC Socket,Relay,Connector.Our parts cover such applications as commercial,industrial, and automotives areas.

We are looking forward to setting up business relationship with you and hope to provide you with the best service and solution. Let us make a better world for our industry!



Contact us

Tel: +86-755-8981 8866 Fax: +86-755-8427 6832

Email & Skype: info@chipsmall.com Web: www.chipsmall.com

Address: A1208, Overseas Decoration Building, #122 Zhenhua RD., Futian, Shenzhen, China



LOC		DIST		REVISIONS		
DF	DO	#	LTR	DESCRIPTION	DATE	DWN
		P		REV PER ECO 08-019991	22OCT08	PK

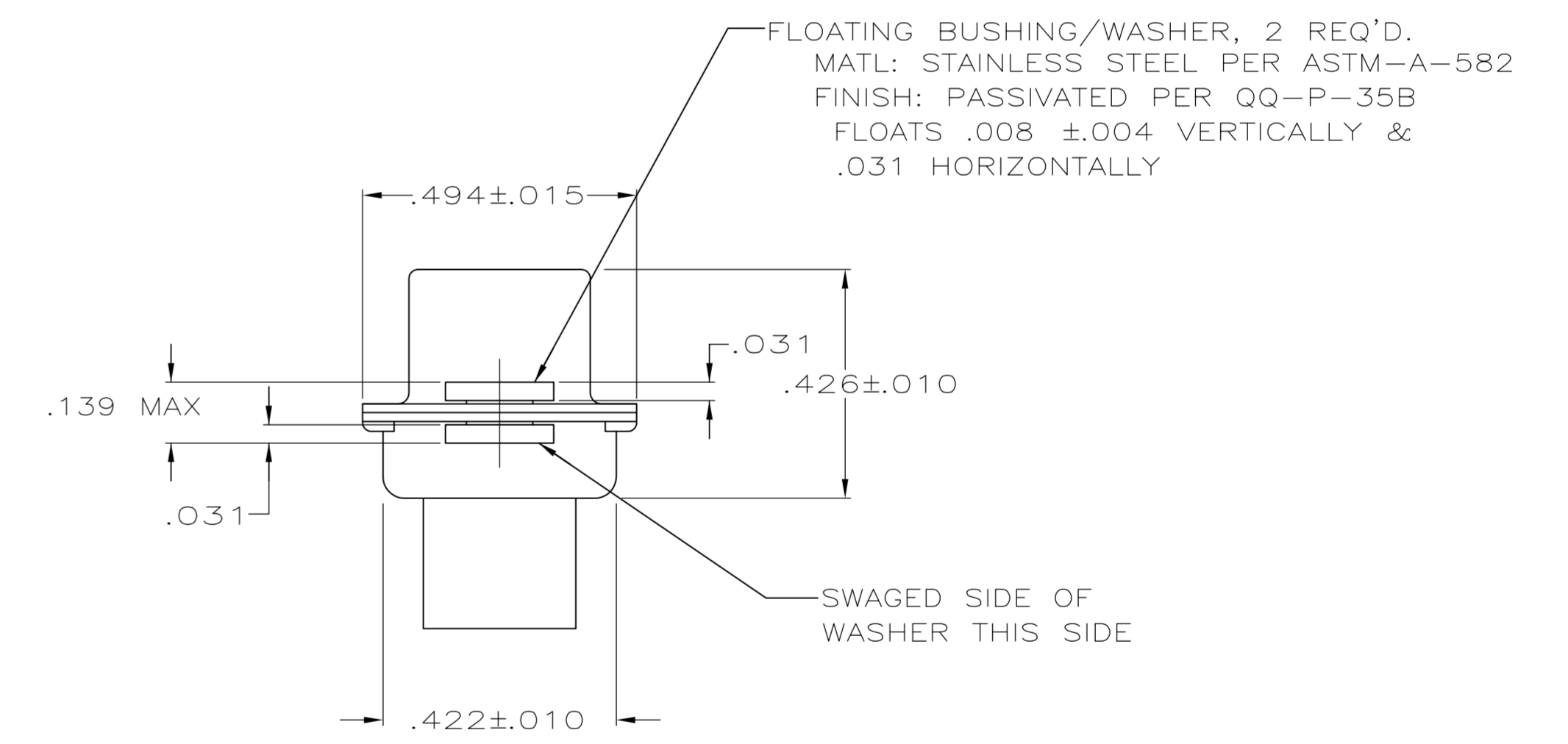
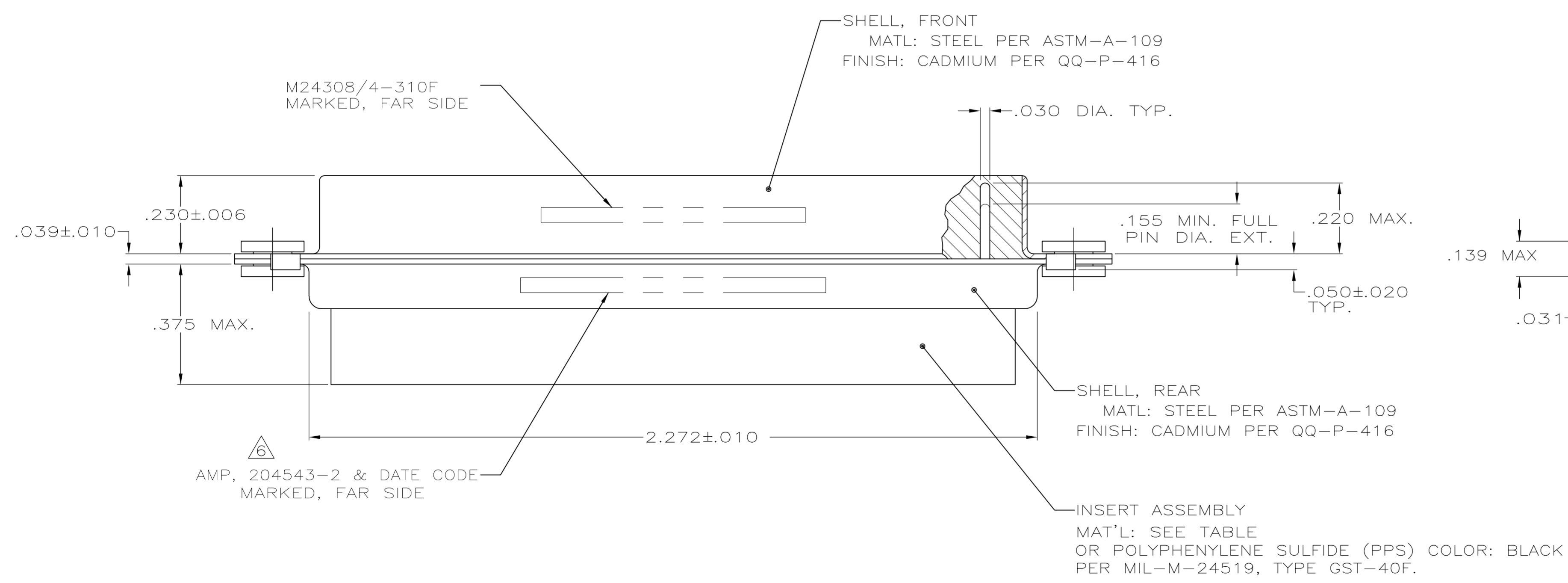
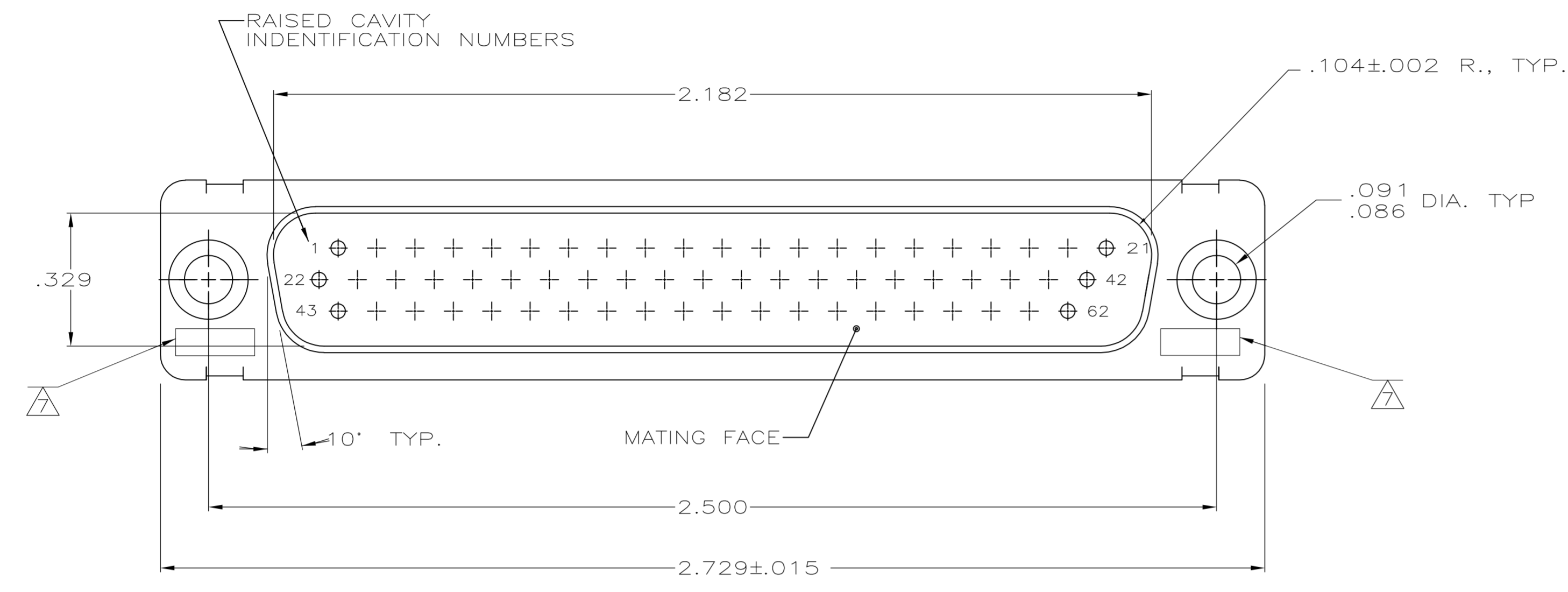

- THIS PLUG IS DESIGNED TO CONFORM TO THE LATEST ISSUE OF MIL-C-24308
 - MAX WIRE INSUL. TO BE USED WITH THIS PLUG IS .054 DIA.
 - METAL RETENTION CLIPS ARE INCLUDED IN INSERTS
 - PACKAGE MARKED M 24308/4-332F
 - THIS PLUG WILL ACCEPT SIZE 22 PIN CONTACT M 24308/13 OR AMP # 204370
- △ AMP PART NO. MARKED ON CONNECTOR REPRESENTS KIT NUMBER WITH CONTACTS
- △ UL/CSA DESIGNATION MARKED IN THIS AREA.

SUPSD BY 204531-1	PHENOLIC COLOR: BLACK	204531-2
	DIALYL PATHALATE COLOR: BLUE	204531-1
	INSERT MAT'L	PART NO

THIS DRAWING IS A CONTROLLED DOCUMENT.		DWN: C.C. THOMAS 12-4-87	Tyco Electronics Corporation Harrisburg, PA 17105-3608
DIMENSIONS: INCHES		CHK: F.C. BALLEW III 1-25-88	
TOLERANCES UNLESS OTHERWISE SPECIFIED:		APVD: F.C. BALLEW III 1-25-88	NAME: AMPLITE PLUG FOR PIN CONTACTS HI-DENSITY D CONNECTOR SIZE4, 62 POSN., SERIES 90 WITH FLOAT BUSHINGS
0 PLC ± -		PRODUCT SPEC	
1 PLC ± -		APPLICATION SPEC	SIZE: A1
2 PLC ± -		FINISH: SEE CALLOUTS	CAGE CODE: 00779
3 PLC ± 0.005		RESTRICTED TO	DRAWING NO: 204531
4 PLC ± -		SCALE: 4:1	SHEET 1 OF 1
ANGLES ± 0°30'		CUSTOMER DRAWING	REV P