



Chipsmall Limited consists of a professional team with an average of over 10 year of expertise in the distribution of electronic components. Based in Hongkong, we have already established firm and mutual-benefit business relationships with customers from,Europe,America and south Asia,supplying obsolete and hard-to-find components to meet their specific needs.

With the principle of “Quality Parts,Customers Priority,Honest Operation,and Considerate Service”,our business mainly focus on the distribution of electronic components. Line cards we deal with include Microchip,ALPS,ROHM,Xilinx,Pulse,ON,Everlight and Freescale. Main products comprise IC,Modules,Potentiometer,IC Socket,Relay,Connector.Our parts cover such applications as commercial,industrial, and automotives areas.

We are looking forward to setting up business relationship with you and hope to provide you with the best service and solution. Let us make a better world for our industry!



Contact us

Tel: +86-755-8981 8866 Fax: +86-755-8427 6832

Email & Skype: info@chipsmall.com Web: www.chipsmall.com

Address: A1208, Overseas Decoration Building, #122 Zhenhua RD., Futian, Shenzhen, China



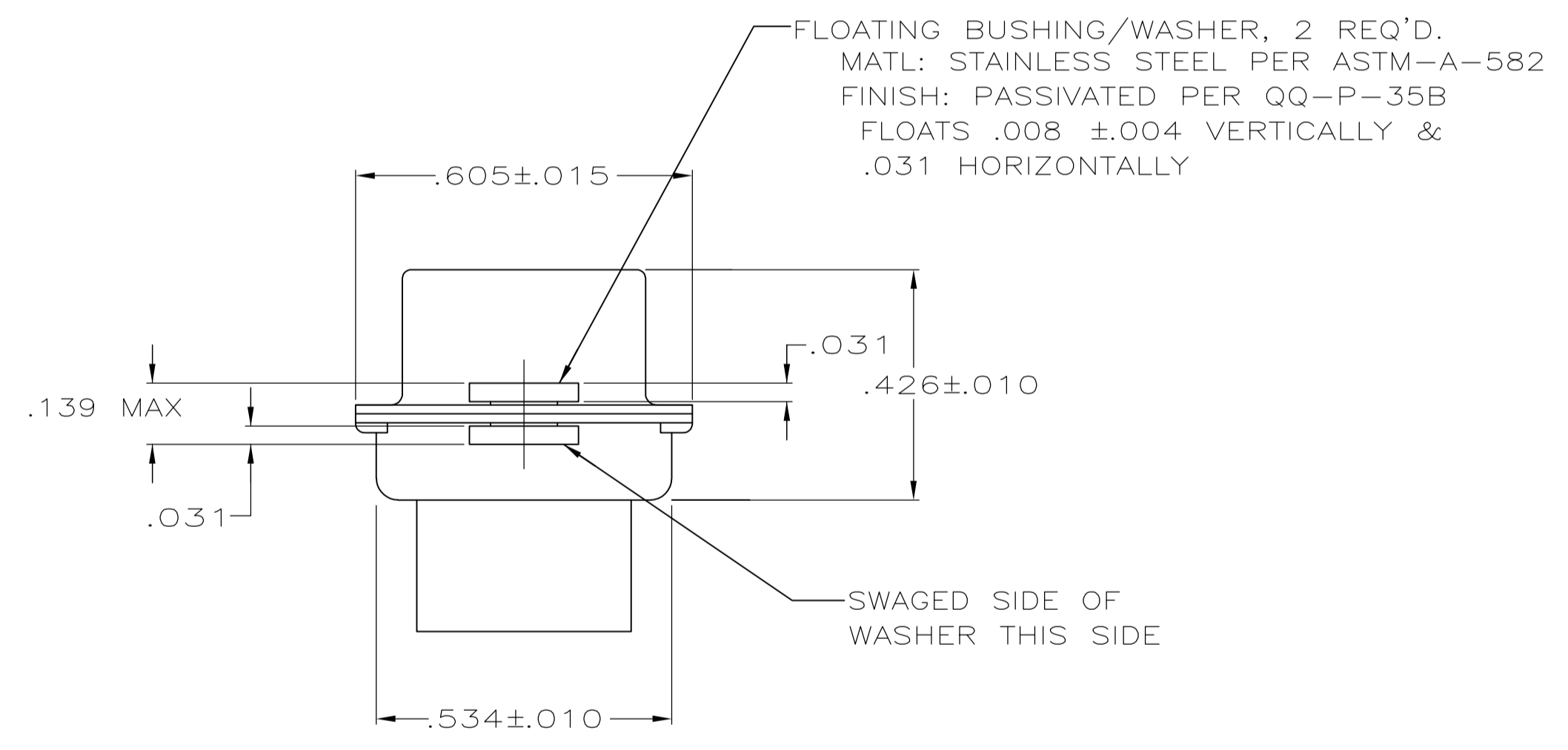
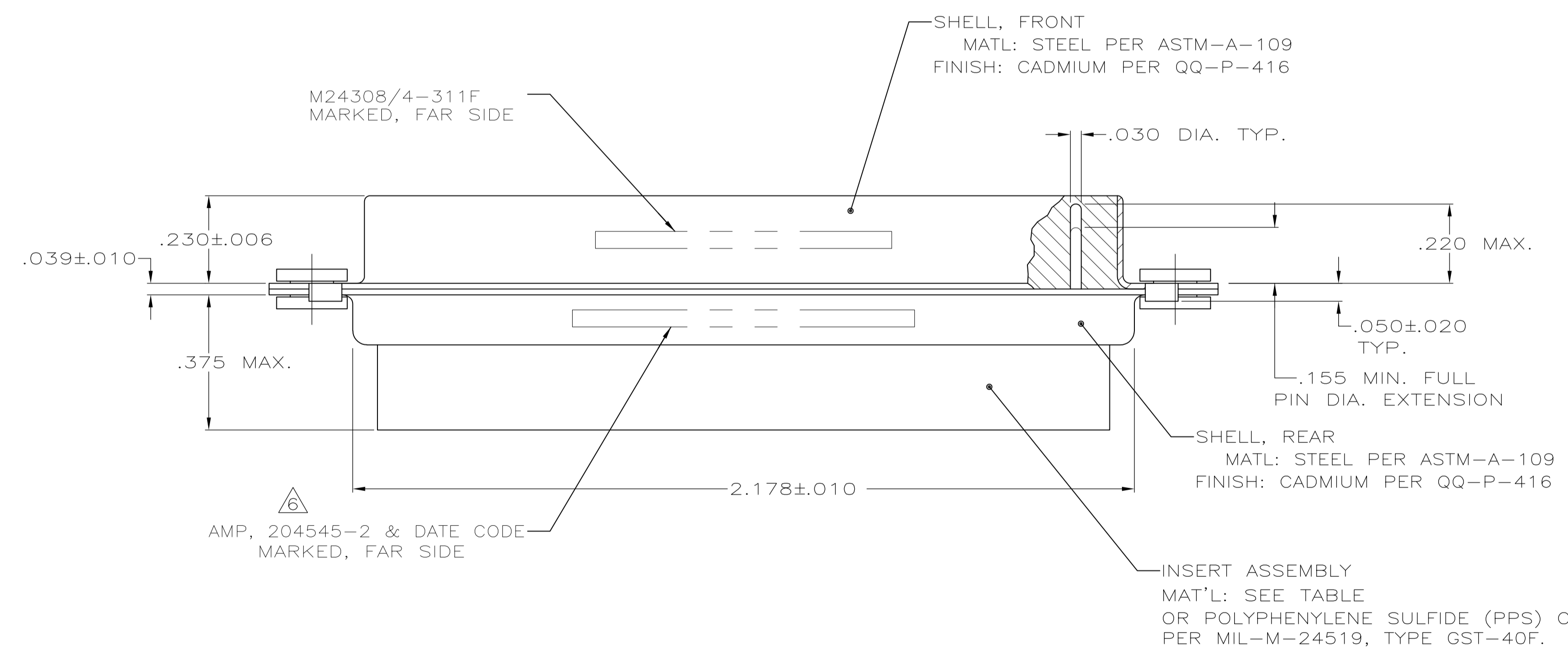
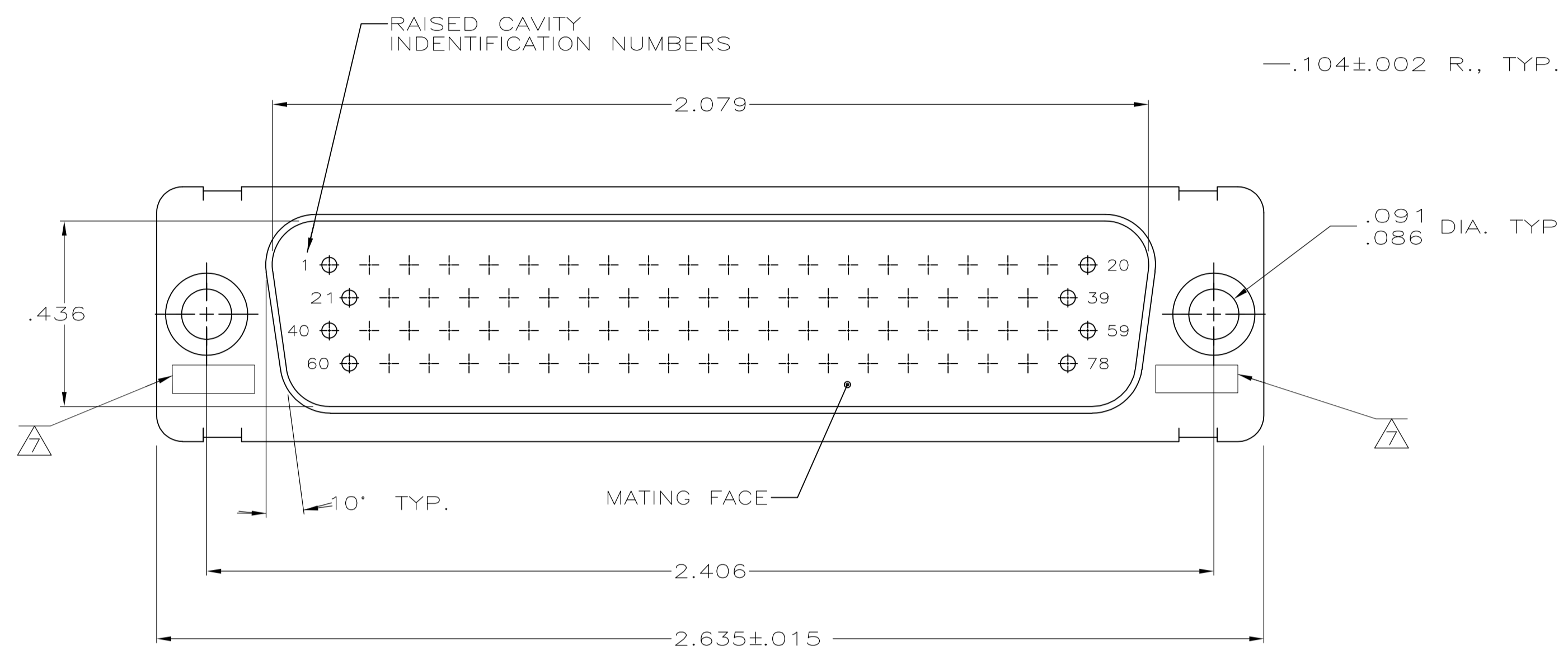

1. THIS PLUG IS DESIGNED TO CONFORM TO THE LATEST ISSUE OF MIL-C-24308
 2. MAX WIRE INSUL. TO BE USED WITH THIS PLUG IS .054 DIA.
 3. METAL RETENTION CLIPS ARE INCLUDED IN INSERTS
 4. PACKAGE MARKED M 24308/4-333F
 5. THIS PLUG WILL ACCEPT SIZE 22 PIN CONTACT M 24308/13 OR AMP # 204370
- AMP PART NO. MARKED ON CONNECTOR REPRESENTS KIT NUMBER WITH CONTACTS
 UL/CSA DESIGNATION MARKED IN THIS AREA.

OBSOLETE	PHENOLIC COLOR: BLACK	204533-3
	DIALYL PATHALATE COLOR: BLUE	204533-1
	INSERT MAT'L	PART NO

THIS DRAWING IS A CONTROLLED DOCUMENT.		DWN C.C.THOMAS 12-4-87	Tyco Electronics Corporation Harrisburg, PA 17105-3608	
DIMENSIONS: INCHES		CHK F.C.BALLEW III 1-25-88	NAME F.C.BALLEW III 1-25-88	
TOLERANCES UNLESS OTHERWISE SPECIFIED:		PRODUCT SPEC		
0 PLC ± -		APPLICATION SPEC		
1 PLC ± -		SIZE		
2 PLC ± -		CAGE CODE		
3 PLC ± .005		DRAWING NO		
4 PLC ± -		RESTRICTED TO		
ANGLES ± 0'30"		A1 00779 C=204533		
MATERIAL SEE CALLOUTS		WEIGHT -		
FINISH SEE CALLOUTS		CUSTOMER DRAWING		
		SCALE 4:1 SHEET 1 OF 1 REV R		