



Chipsmall Limited consists of a professional team with an average of over 10 year of expertise in the distribution of electronic components. Based in Hongkong, we have already established firm and mutual-benefit business relationships with customers from,Europe,America and south Asia,supplying obsolete and hard-to-find components to meet their specific needs.

With the principle of “Quality Parts,Customers Priority,Honest Operation,and Considerate Service”,our business mainly focus on the distribution of electronic components. Line cards we deal with include Microchip,ALPS,ROHM,Xilinx,Pulse,ON,Everlight and Freescale. Main products comprise IC,Modules,Potentiometer,IC Socket,Relay,Connector.Our parts cover such applications as commercial,industrial, and automotives areas.

We are looking forward to setting up business relationship with you and hope to provide you with the best service and solution. Let us make a better world for our industry!



## Contact us

Tel: +86-755-8981 8866 Fax: +86-755-8427 6832

Email & Skype: info@chipsmall.com Web: www.chipsmall.com

Address: A1208, Overseas Decoration Building, #122 Zhenhua RD., Futian, Shenzhen, China



LOC	DIST	REV	DESCRIPTION	DATE	DWN	APVD
GP	00	A	RELEASE PER ECO-10-025263	15FEB2011	CJV	JTL

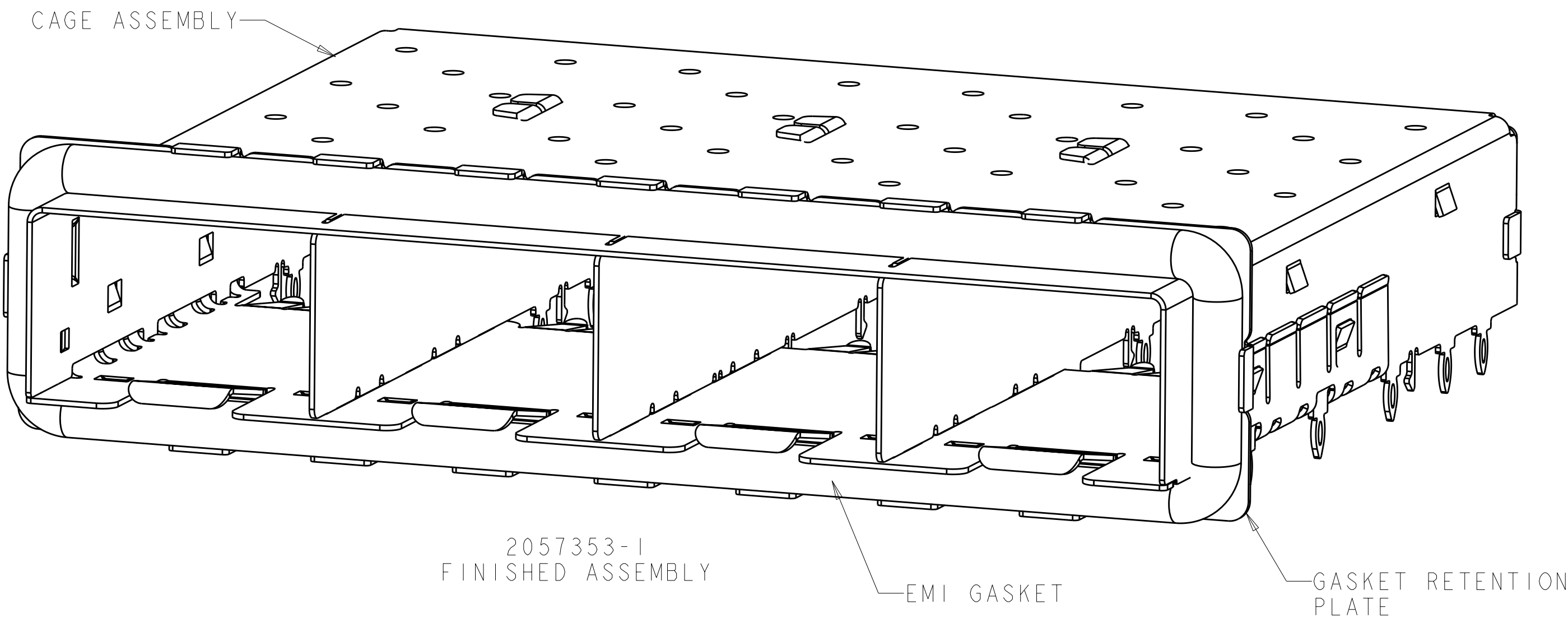

- 1 MATERIAL:  
 CAGE ASSEMBLY: NICKEL SILVER ALLOY  
 GASKET RETENTION PLATE: STAINLESS STEEL  
 EMI GASKET: PLATED FILLED SILICONE
- 2 MINIMUM PC BOARD THICKNESS:  
 SINGLE SIDED = 1.45mm
- 3 PADS AND VIAS CHASSIS GROUND.
- 4 DATUM AND BASIC DIMENSION ESTABLISHED BY CUSTOMER.
- 5. MATES WITH SFP MSA COMPLIANT TRANSCEIVERS.
- 6. INTERPRETATION OF DATUM REFERENCE FRAME IN ACCORDANCE WITH SECT 4.4.1.1 OF ASME Y14.5M-1994.
- 7 REFERENCE APPLICATION SPEC. 114-13120, HOLE A, FOR RECOMMENDED DRILL HOLE DIAMETER AND PLATING THICKNESS.
- 8 REFERENCE APPLICATION SPEC. 114-13120, HOLE B, FOR RECOMMENDED DRILL HOLE DIAMETER AND PLATING THICKNESS.
- 9 HOLE PATTERN REPEATS FOR EACH PORT. SPACING BETWEEN PORTS IS 14.25mm.

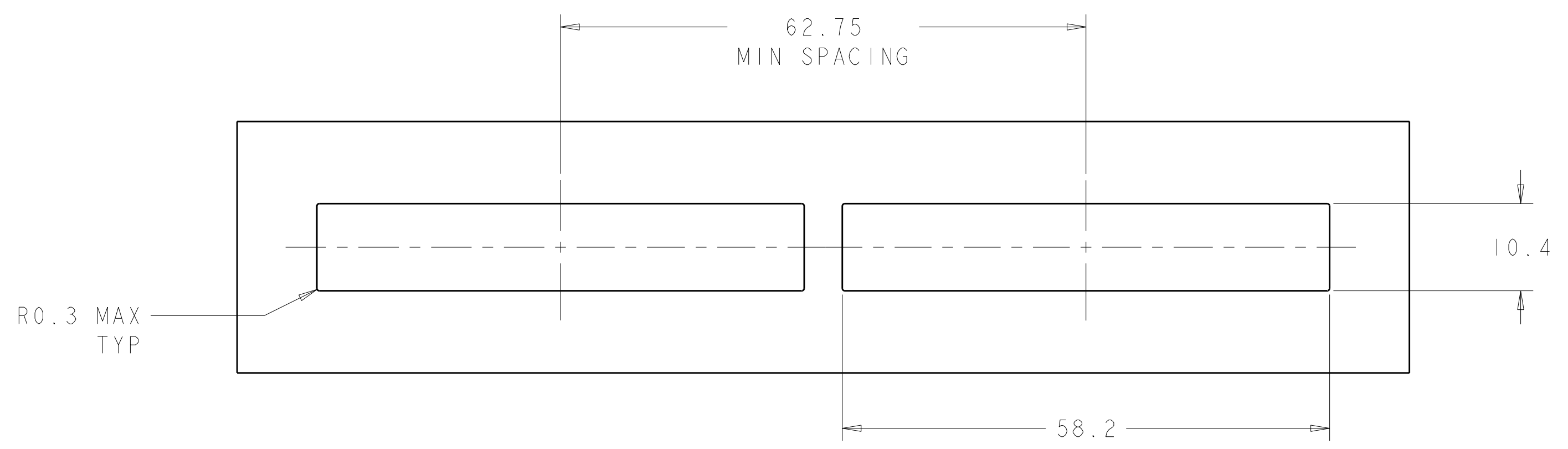
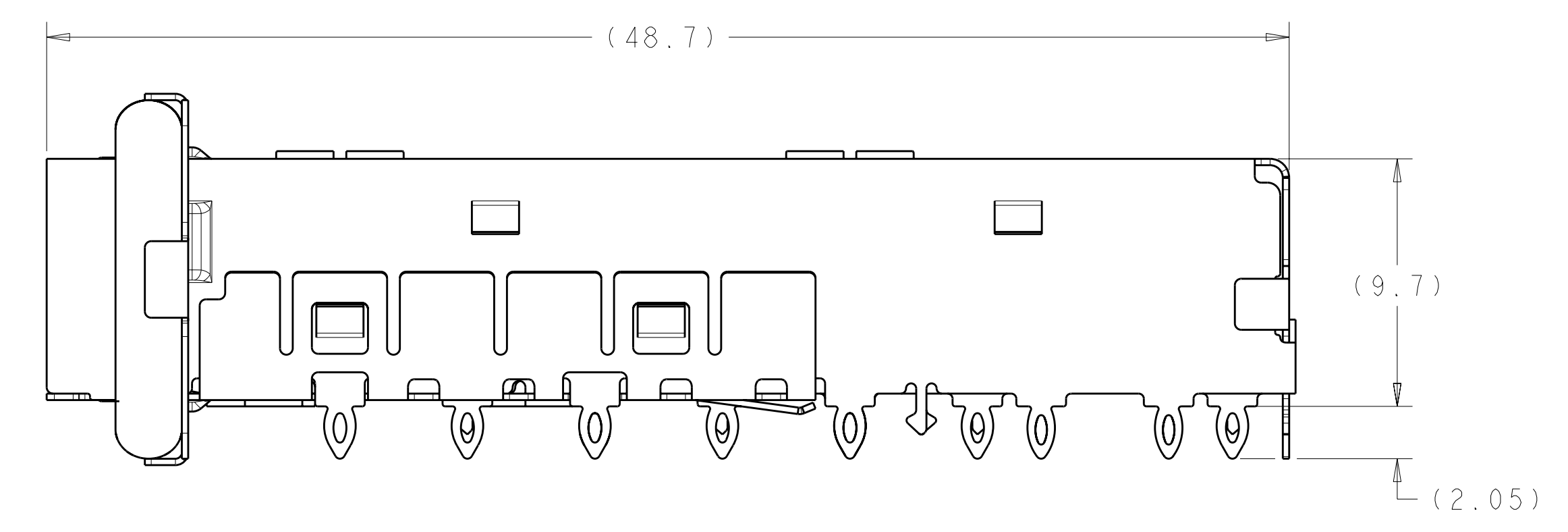
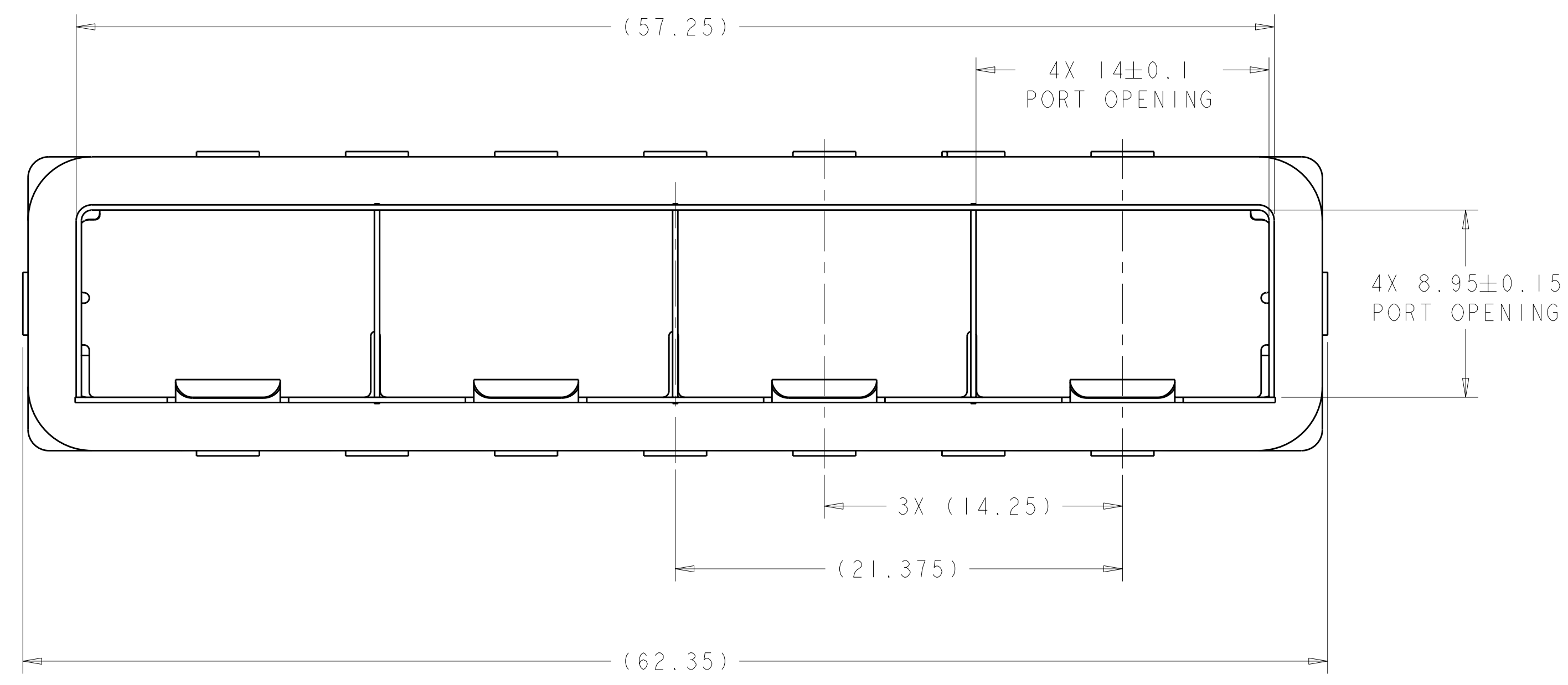

0.23<sup>+0.10</sup><sub>-0.14</sub>  
 TOP OF PCB  
 TO INSIDE OF  
 BEZEL CUT-OUT

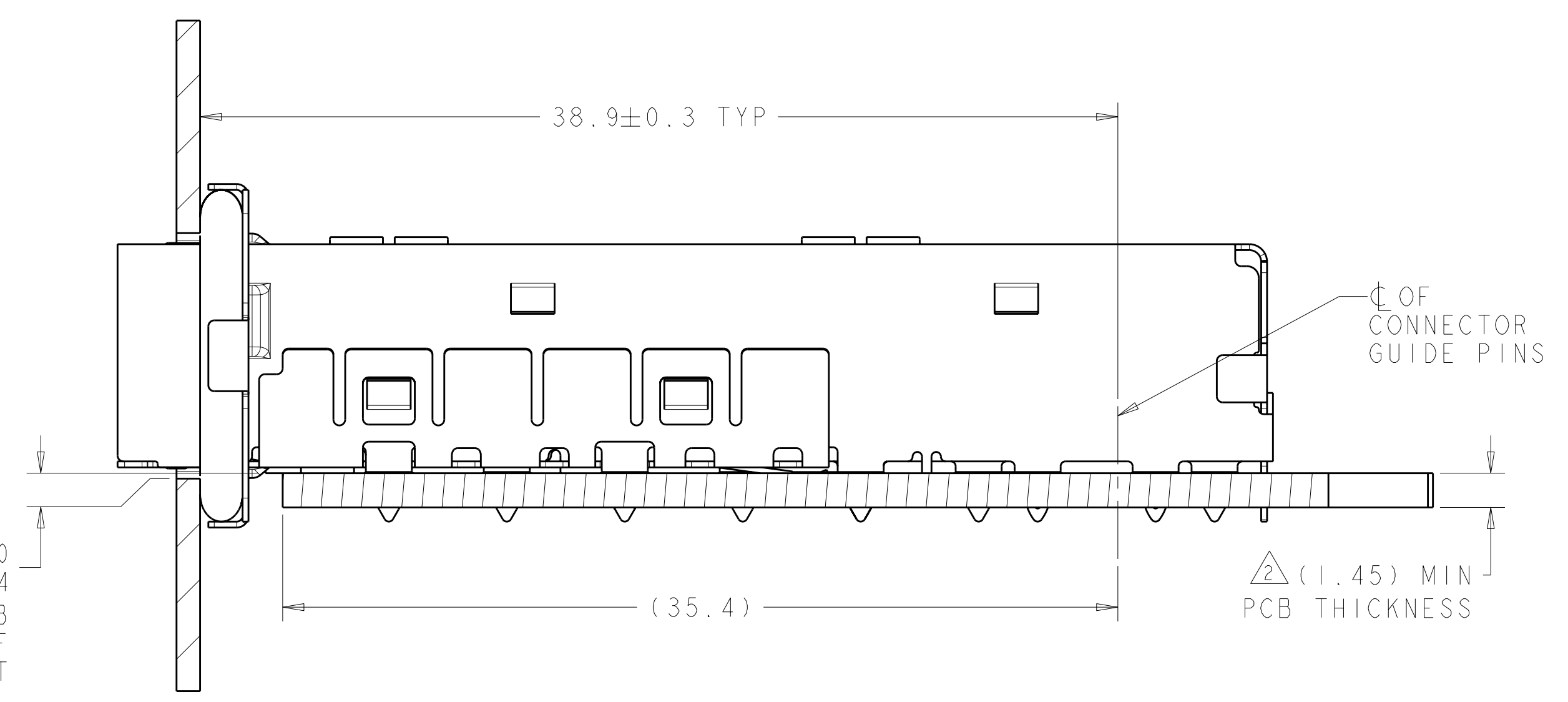

RECOMMENDED BEZEL CUT-OUT  
 SINGLE SIDED APPLICATIONS  
 SCALE 2:1

2057353-1  
 MOUNTED ON PC BOARD  
 SHOWN THRU RECOMMENDED BEZEL  
 SECTION

2057353-1  
 PART  
 NUMBER

DIMENSIONS: mm 		TOLERANCES UNLESS OTHERWISE SPECIFIED: 9 PLC ±0.1 1 PLC ±0.1 2 PLC ±0.1 3 PLC ±0.1 4 PLC ±0.1 ANGLES ±0.1 FINISH #1		DWN ID MCMASTER 19AUG08 CHK M SCHMITT 19AUG08 APVD M SCHMITT 19AUG08		Tyco Electronics Harrisburg, PA 17105-3608	
MATERIAL 		WEIGHT -		NAME SFP+ ENHANCED 1X4 CAGE ASSEMBLY, PRESS-FIT		SIZE CAGE CODE DRAWING NO A 100779 C-2057353	
CUSTOMER DRAWING				SCALE 5:1 SHEET 1 OF 2 REV A		RESTRICTED TO	

LOC	DIST	REV	DATE	BY	APPD
GP	00				

REVISIONS		DATE	BY	APPD
1	SEE SHEET 1			

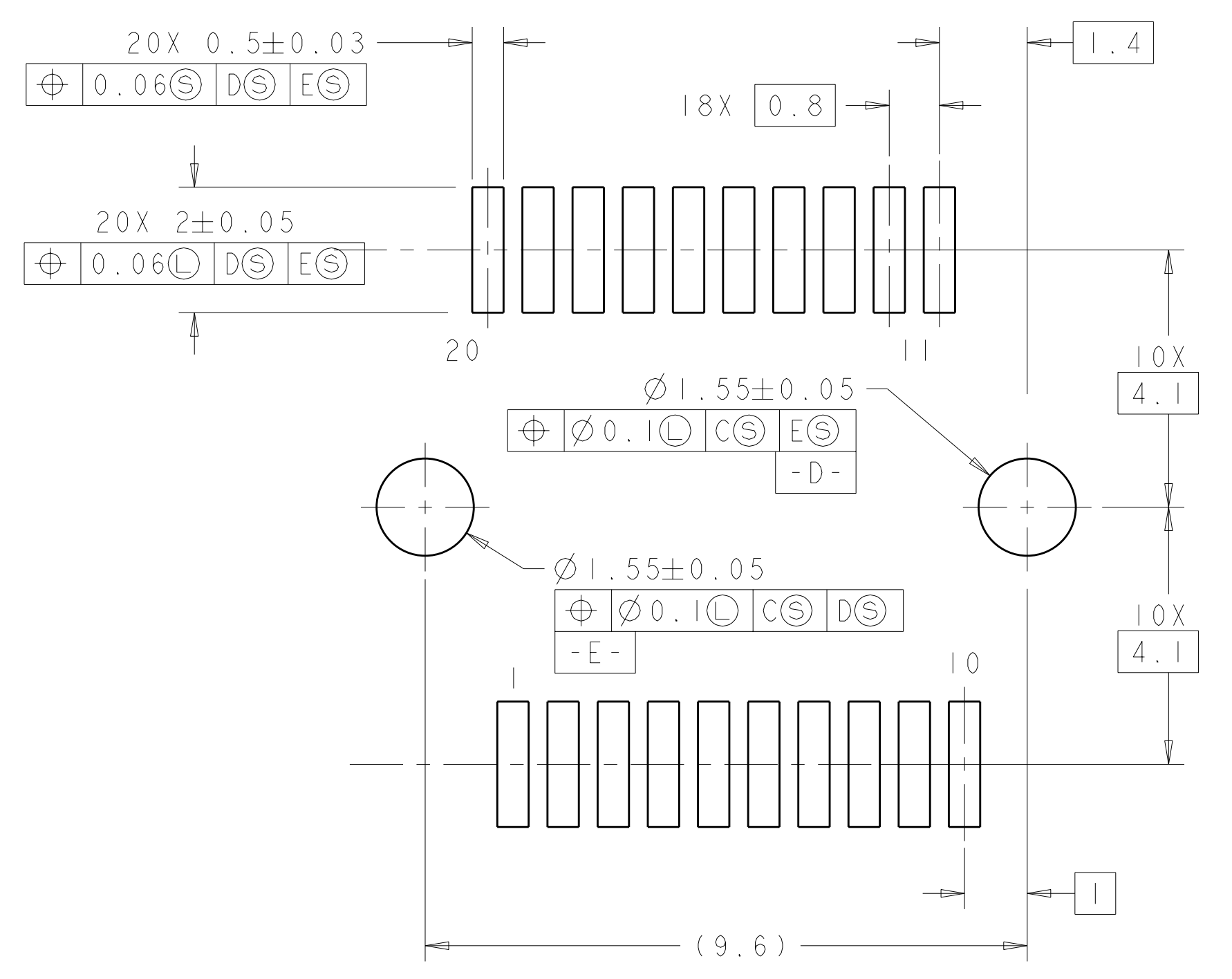
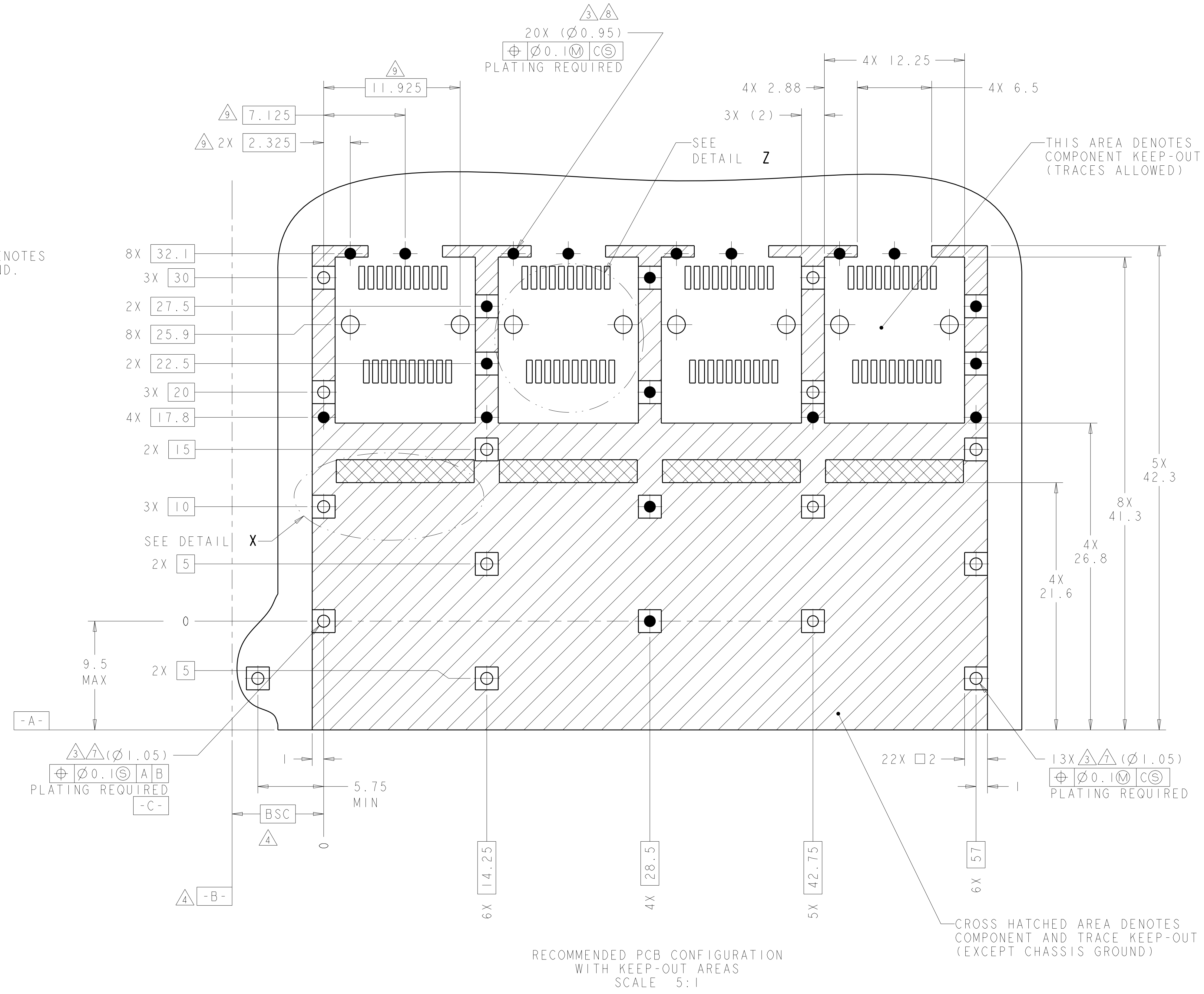
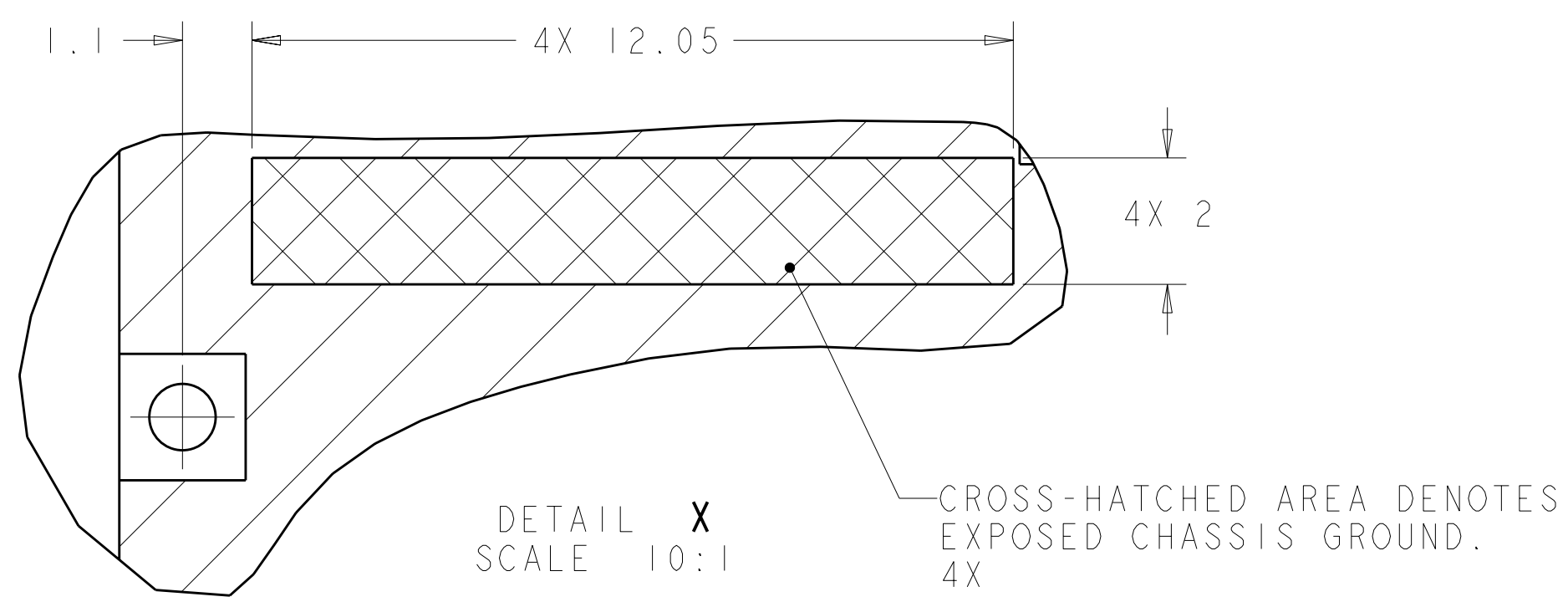

DIMENSIONS:		TOLERANCES UNLESS OTHERWISE SPECIFIED:		DWN B MCMMASTER 19AUG08		Tyco Electronics Harrisburg, PA 17105-3608	
mm	9 PLC ±0.1	1 PLC ±0.1	5 PLC ±0.1	4 PLC ±0.1	APVD M SCHMITT 19AUG08	NAME SFP+ ENHANCED 1X4 CAGE ASSEMBLY, PRESS-FIT	
	108-2364	APPLICATION SPEC		114-13120		SIZE CAGE CODE DRAWING NO	RESTRICTED TO
MATERIAL	FINISH	WEIGHT	A 100779 C=2057353		SCALE 5:1 SHEET 2 OF 2 REV A		