



Chipsmall Limited consists of a professional team with an average of over 10 year of expertise in the distribution of electronic components. Based in Hongkong, we have already established firm and mutual-benefit business relationships with customers from,Europe,America and south Asia,supplying obsolete and hard-to-find components to meet their specific needs.

With the principle of “Quality Parts,Customers Priority,Honest Operation,and Considerate Service”,our business mainly focus on the distribution of electronic components. Line cards we deal with include Microchip,ALPS,ROHM,Xilinx,Pulse,ON,Everlight and Freescale. Main products comprise IC,Modules,Potentiometer,IC Socket,Relay,Connector.Our parts cover such applications as commercial,industrial, and automotives areas.

We are looking forward to setting up business relationship with you and hope to provide you with the best service and solution. Let us make a better world for our industry!



## Contact us

Tel: +86-755-8981 8866 Fax: +86-755-8427 6832

Email & Skype: info@chipsmall.com Web: www.chipsmall.com

Address: A1208, Overseas Decoration Building, #122 Zhenhua RD., Futian, Shenzhen, China



LOC		DIST		P		F		ZONE		LTR		REVISIONS		DATE	APPD	
DF	DO												REV PER 063D-0583-02	CT	1-03	DM

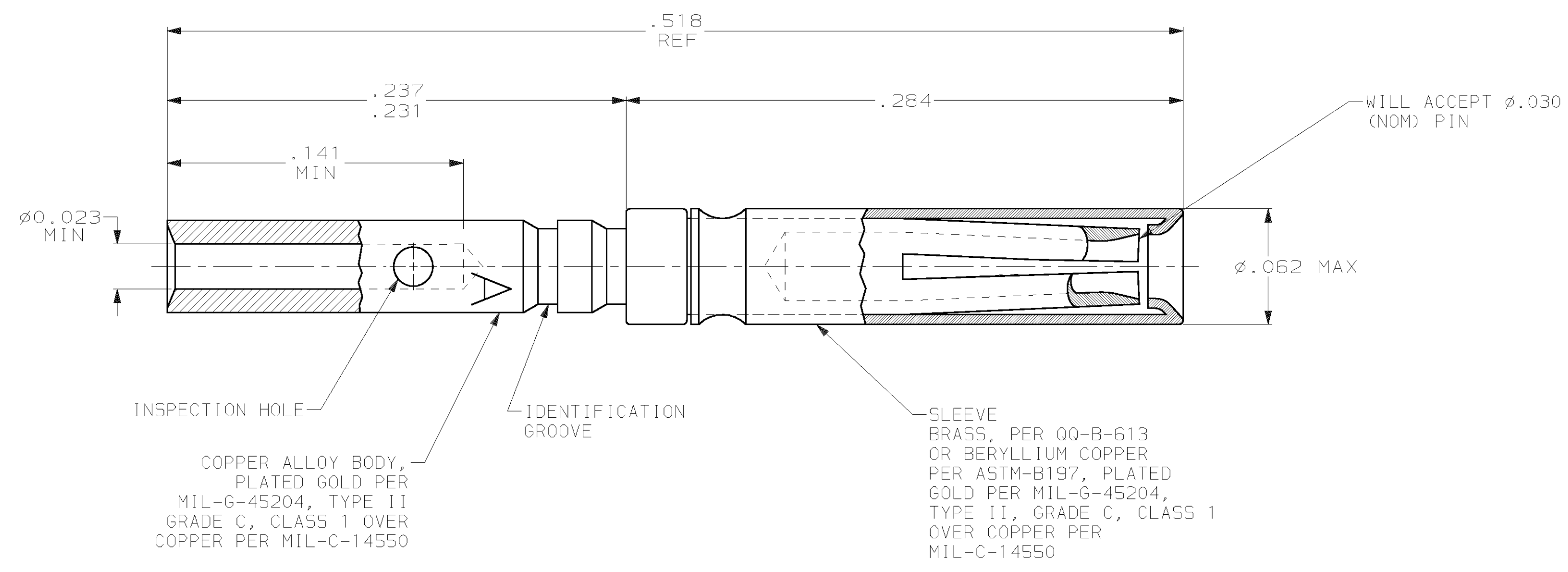

PRESS FIT HOOD CONFIGURATION

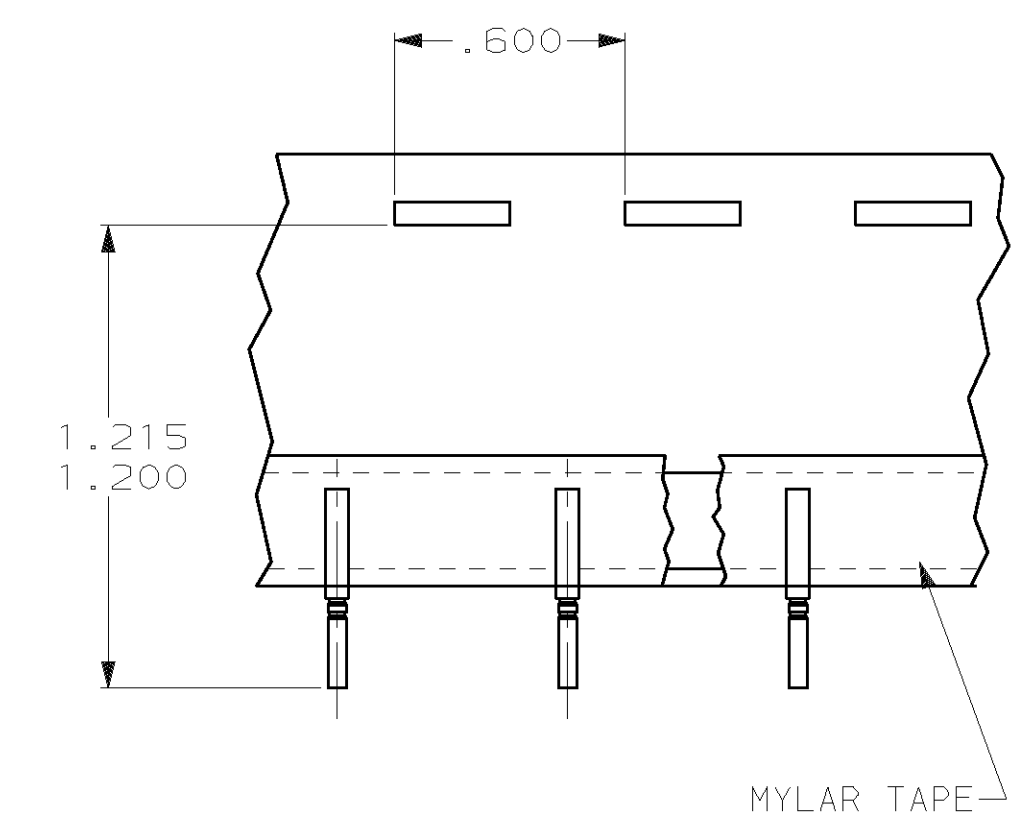

TAPE MOUNTED  
 -2 ONLY

1. WIRE BARREL WILL ACCEPT #26 - 28 AWG WIRE.
2. CRIMPING TOOL - USE HANDTOOL M22520/2-01 (AMP P/N 601996-1) WITH POSITIONER M22520/2-06 (AMP P/N 601966-4) SEE AMP INSTRUCTION SHEET, IS7516, FOR CRIMPING INSTRUCTIONS.
3. CONTACT CONFORMS TO MIL-C-24308/57-354, EXCEPT NO COLOR CODE AND INSIDE DIAMETER ON CRIMP BARREL IS SMALLER TO ACCEPT #26 - 28 AWG WIRE.
4. INSERTION/EXTRACTION TOOL AMP P/N 91067-1.
5. USE AMP - TAPOMATIC STRIPPER/CRIMPER MACHINE NUMBER 299406-7 WITH FUNNEL NUMBER 125905-2.
6. SLEEVE MAY BE CRIMPED OR DIMPLED ONTO CONTACT BODY.

AS SHOWN EXCEPT ON TAPE		206496-2	
AS SHOWN		206496-1	
DESCRIPTION		PART NO	
DO NOT SCALE PRINT. UNLESS SPECIFIED DIMENSIONS IN mm [INCHES] TOLERANCES ON : 2 PLC DEC ± - 3 PLC DEC ± .005 ANGLES ± -		DR 06-03-94 T. THOMPSON	
MATERIAL		AMP Incorporated Harrisburg, PA 17105-3508	
FINISH		NAME	
SEE CALLOUT		CONTACT ASSEMBLY, SOCKET, SIZE 22D	
APPLICATION SPEC		SIZE	CAGE CODE
-		D	00779
WEIGHT		DRAWING NO	
.103 GRAMS		C-206496	
		SCALE	SHEET
		20:1	1 OF 1

THIS DRAWING IS A CONTROLLED DOCUMENT FOR AMP INCORPORATED. IT IS SUBJECT TO CHANGE AND THE CONTROLLING ENGINEERING ORGANIZATION SHOULD BE CONTACTED FOR THE LATEST REVISION.