



Chipsmall Limited consists of a professional team with an average of over 10 year of expertise in the distribution of electronic components. Based in Hongkong, we have already established firm and mutual-benefit business relationships with customers from,Europe,America and south Asia,supplying obsolete and hard-to-find components to meet their specific needs.

With the principle of "Quality Parts,Customers Priority,Honest Operation,and Considerate Service",our business mainly focus on the distribution of electronic components. Line cards we deal with include Microchip,ALPS,ROHM,Xilinx,Pulse,ON,Everlight and Freescale. Main products comprise IC,Modules,Potentiometer,IC Socket,Relay,Connector.Our parts cover such applications as commercial,industrial, and automotives areas.

We are looking forward to setting up business relationship with you and hope to provide you with the best service and solution. Let us make a better world for our industry!



Contact us

Tel: +86-755-8981 8866 Fax: +86-755-8427 6832

Email & Skype: info@chipsmall.com Web: www.chipsmall.com

Address: A1208, Overseas Decoration Building, #122 Zhenhua RD., Futian, Shenzhen, China



KEYING OPTION, SCALE: 2:1

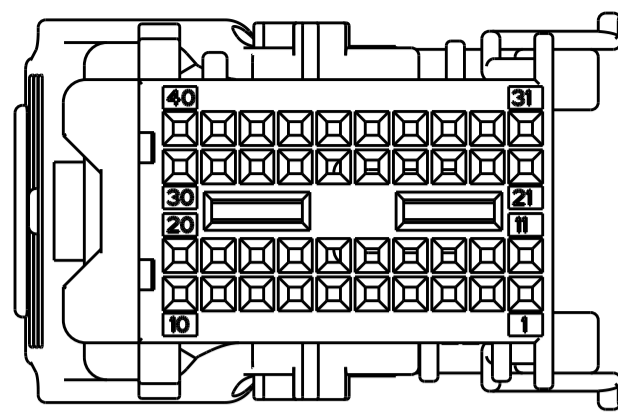

ASSY P/N: 2098633-1
KEYING: A

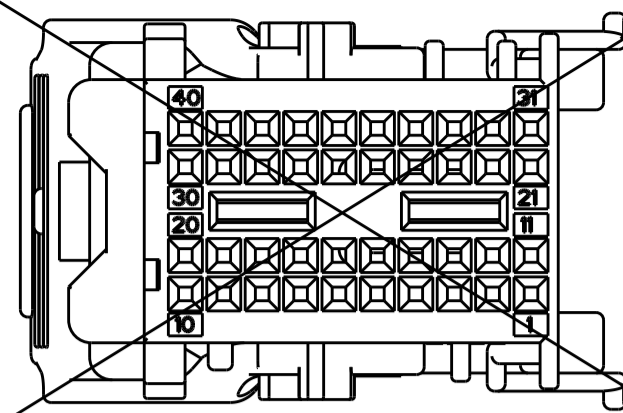

ASSY P/N: 2098633-2
KEYING: B

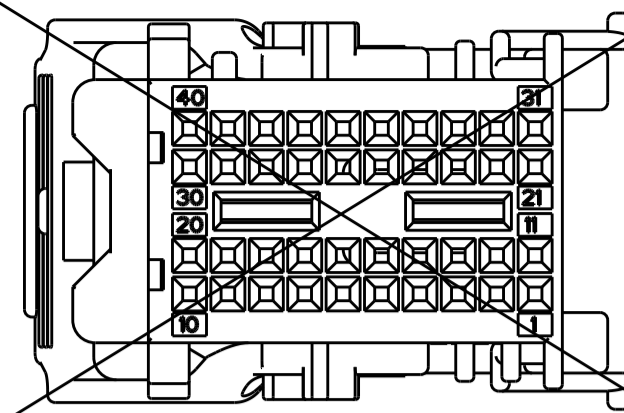

ASSY P/N: 2098633-3
KEYING: C

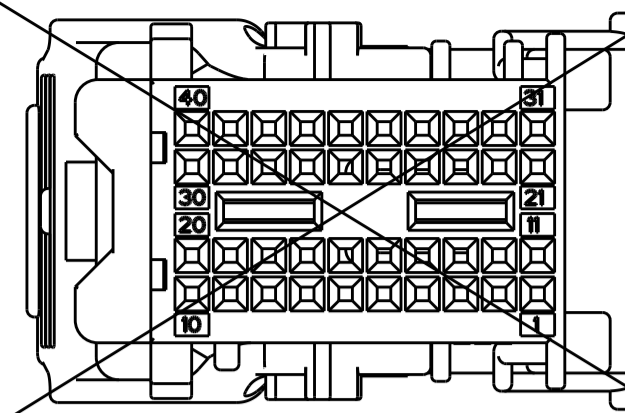

ASSY P/N: 2098633-4
KEYING: D

REVISIONS				
P.	LTN.	DESCRIPTION	DATE	APV'D
A		REVISED PER ECR-12-010595	11JUN2012	MBH RH
B		REVISED PER ECO-15-011566	15SEP2015	DLD CJS

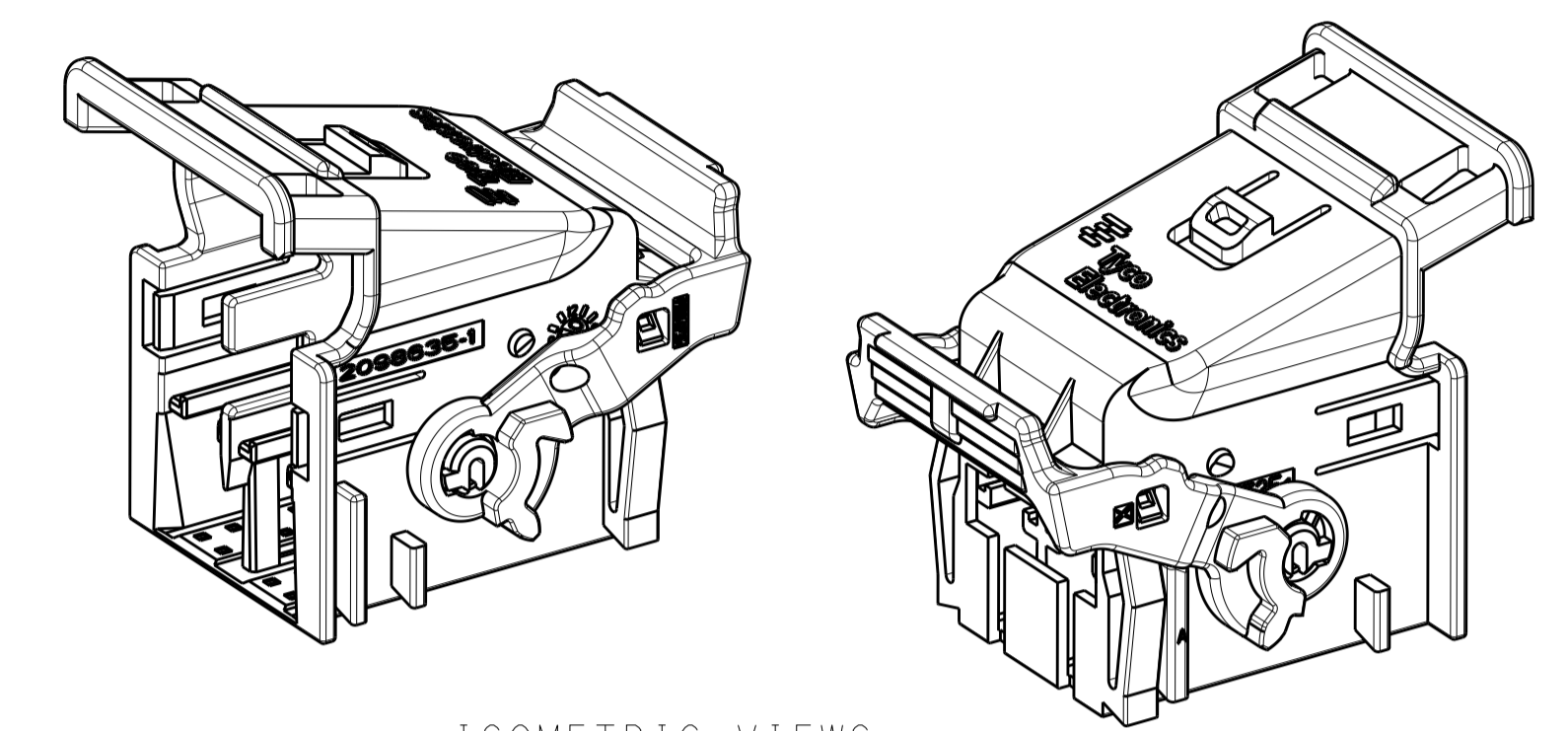
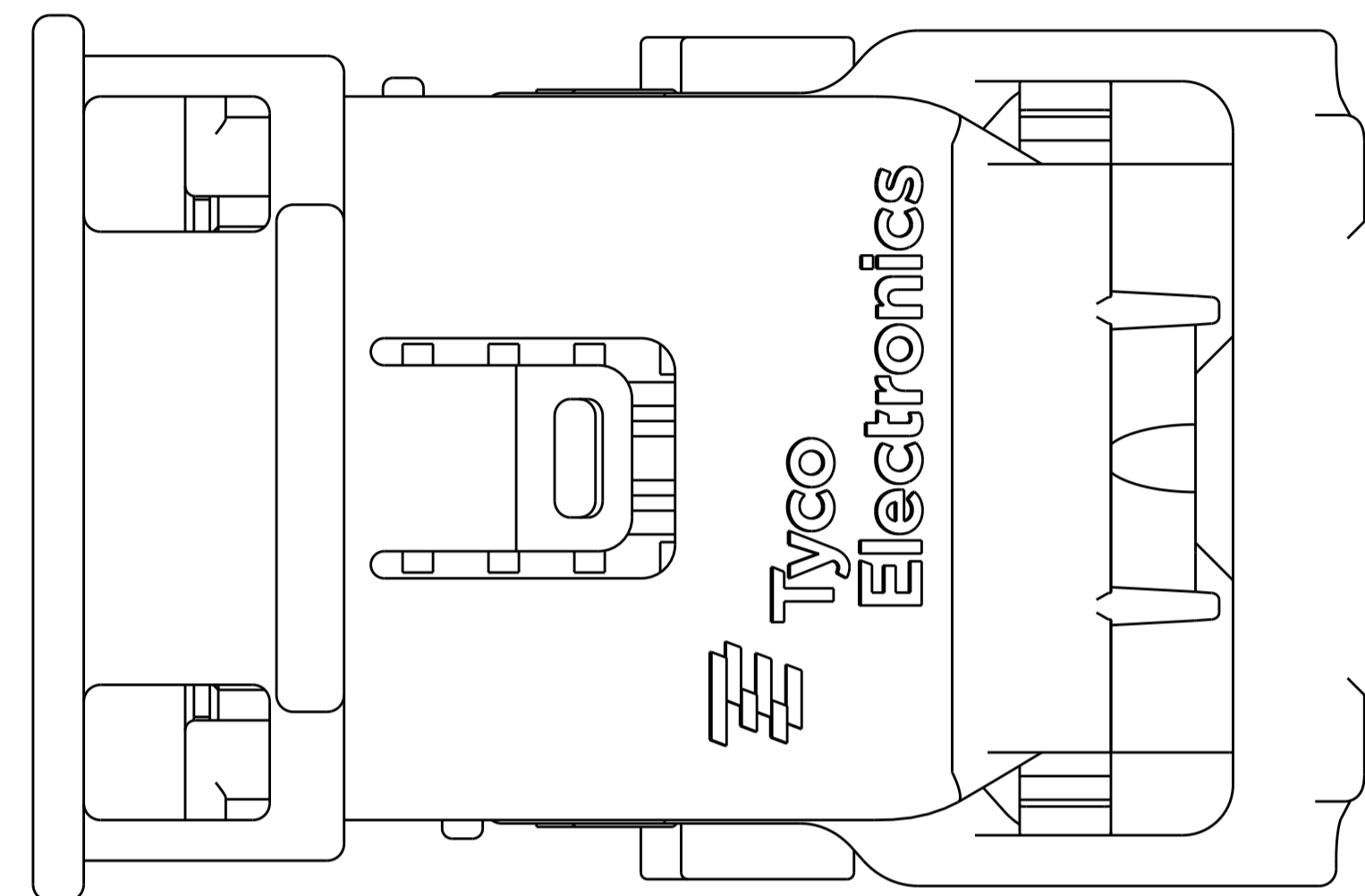

ISOMETRIC VIEWS
SCALE 2:1

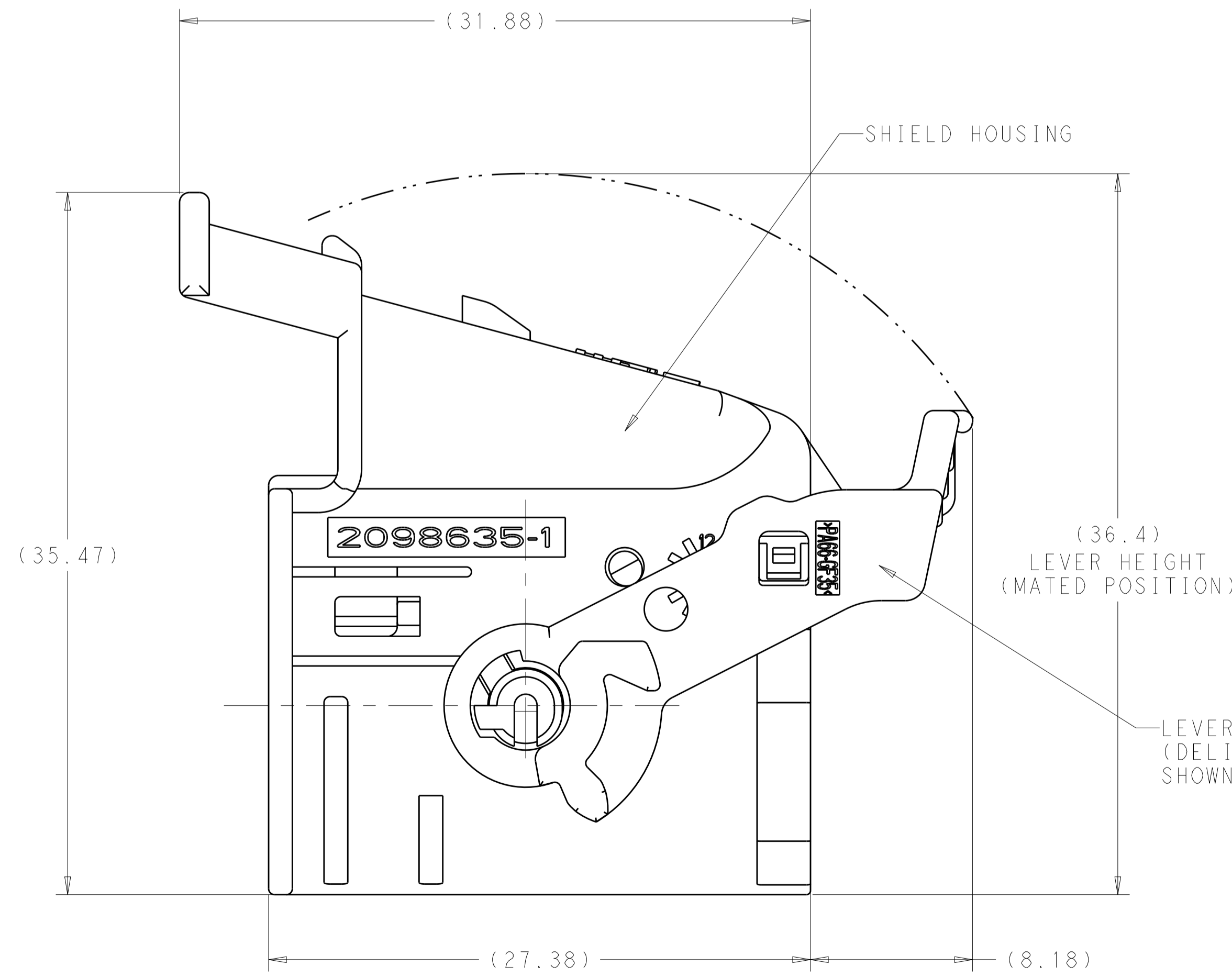
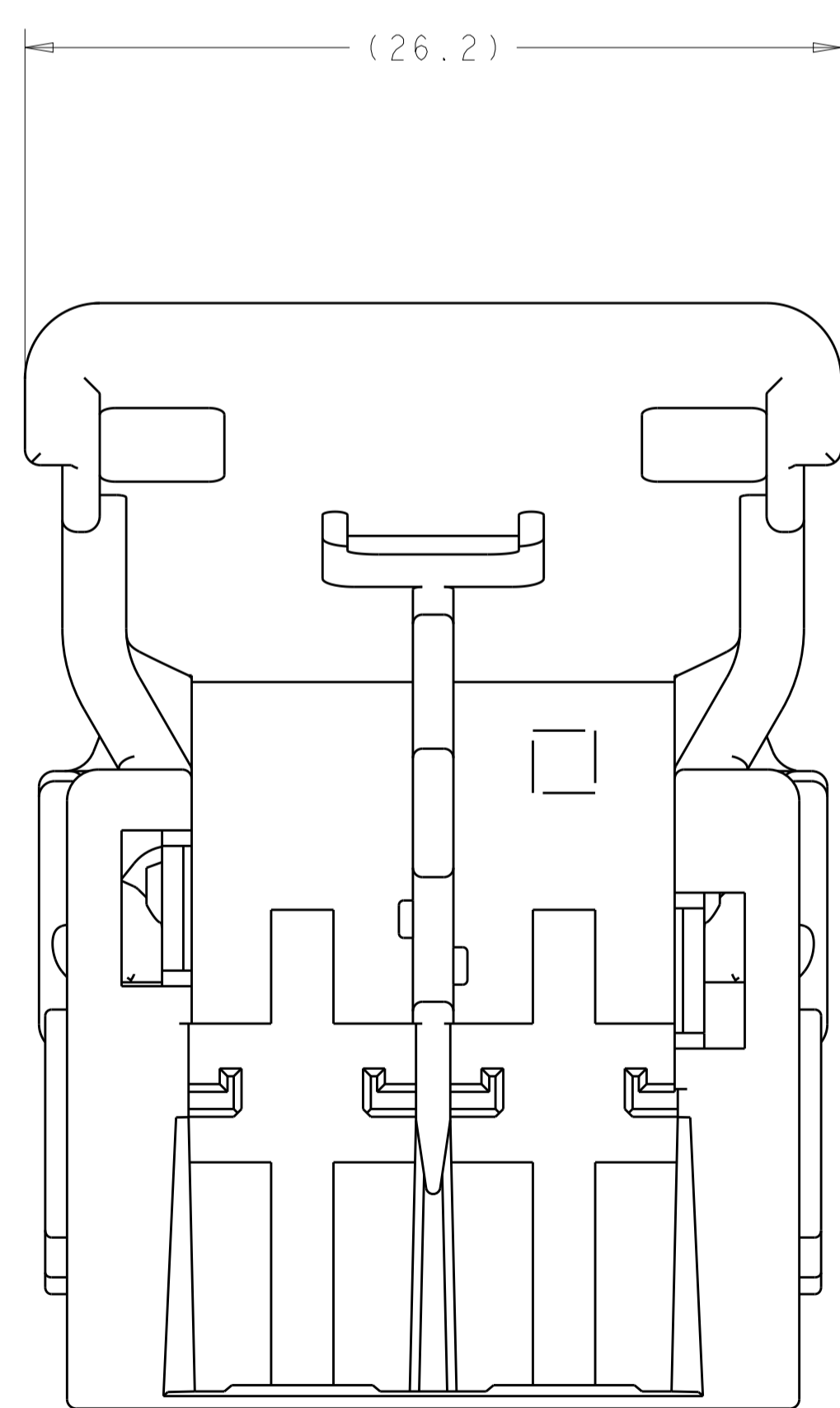

- 1. MATERIAL: SHIELD - 35% GLASS REINFORCED NYLON. SEE TABLE BELOW FOR COLOR. LEVER - 35% GLASS REINFORCED NYLON. COLOR: DARK GREY.
- 2. REFERENCE: CARRIER 2098634-1 AND 2098634-2 USED WITH THIS ASSEMBLY.
- 3. REFERENCE: INTERFACE DETAIL PER TE DRAWING NO 2098633-MXCU.

COLOR	KEYING OPT.	PART NUMBER
BLACK	D	2098633-4
BLUE	C	2098633-3
GREY	B	2098633-2
BLACK	A	2098633-1

THIS DRAWING IS A CONTROLLED DOCUMENT.		OWN: S. VINAY 22MAR2010	TE Connectivity
DIMENSIONS: mm		CHK: M. GALEN 22MAR2010	
TOLERANCES UNLESS OTHERWISE SPECIFIED:		APV'D: M. GALEN 22MAR2010	NAME: SHIELD ASSEMBLY, 40 POSITION GENERATION Y LAC
0 PLC	±	PRODUCT SPEC	SIZE: CAGE CODE DRAWING NO
1 PLC	±	APPLICATION SPEC	RESTRICTED TO
2 PLC	±	WEIGHT	A100779C=2098633
3 PLC	±	CUSTOMER DRAWING	SCALE 5:1 SHEET 1 OF 1 REV B
4 PLC	±		
ANGLES	±1°		
MATERIAL			