



Chipsmall Limited consists of a professional team with an average of over 10 year of expertise in the distribution of electronic components. Based in Hongkong, we have already established firm and mutual-benefit business relationships with customers from,Europe,America and south Asia,supplying obsolete and hard-to-find components to meet their specific needs.

With the principle of “Quality Parts,Customers Priority,Honest Operation,and Considerate Service”,our business mainly focus on the distribution of electronic components. Line cards we deal with include Microchip,ALPS,ROHM,Xilinx,Pulse,ON,Everlight and Freescale. Main products comprise IC,Modules,Potentiometer,IC Socket,Relay,Connector.Our parts cover such applications as commercial,industrial, and automotives areas.

We are looking forward to setting up business relationship with you and hope to provide you with the best service and solution. Let us make a better world for our industry!



## Contact us

Tel: +86-755-8981 8866 Fax: +86-755-8427 6832

Email & Skype: info@chipsmall.com Web: www.chipsmall.com

Address: A1208, Overseas Decoration Building, #122 Zhenhua RD., Futian, Shenzhen, China



# FMC Carrier-S6™ Board Reference Manual



Revision: March 26, 2013

Note: This document applies to REV B of the board.

1300 Henley Court | Pullman, WA 99163  
(509) 334 6306 Voice and Fax

## Overview

The FMC Carrier-S6 circuit board is a digital circuit development platform based on a Xilinx Spartan-6 LX45 FPGA. The large FPGA along with the high-pin count FMC socket, 128MByte DDR2 on-board memory, and compact PCB size make this an ideal FMC Host controller board for embedded processor designs based on Xilinx's MicroBlaze.

FMC Carrier-S6 is compatible with all Xilinx CAD tools, including ChipScope, EDK, and the free ISE WebPack™, so designs can be completed at no extra cost.

The Spartan-6 LX45 is optimized for high-performance logic and offers:

- 6,822 slices, each containing four 6-input LUTs and eight flip-flops
- 2.1Mbits of fast block RAM
- four clock tiles (eight DCMs & four PLLs)
- 58 DSP slices
- 500MHz+ clock speeds

The FMC Carrier-S6 board includes Digilent's Adept USB2 system, which offers device programming and user-data transfer facilities.

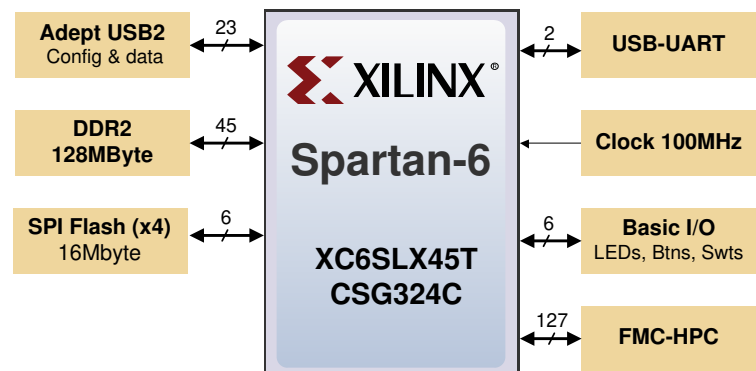

## Features

- Xilinx Spartan-6 LX45 FPGA, 324-pin BGA package
- 128Mbyte DDR2 with 16-bit wide data
- on-board USB2 port for programming and data transfer
- USB-UART
- 16Mbyte x4 SPI Flash for configuration and data storage
- 100MHz Oscillator
- Over 120 GPIO signals available through FMC HPC
- GPIO includes 2 LEDs, 2 buttons, and 2 slide switches
- ships with 12V power supply and USB cable

## Configuration

After power-on, the FPGA on the FMC Carrier – S6 board must be configured (or programmed) before it can perform any functions. The FPGA can be configured in two ways: a USB-connected PC can configure the board using the JTAG port any time power is on and a configuration file stored in the SPI Flash ROM can be automatically transferred to the FPGA at power-on.

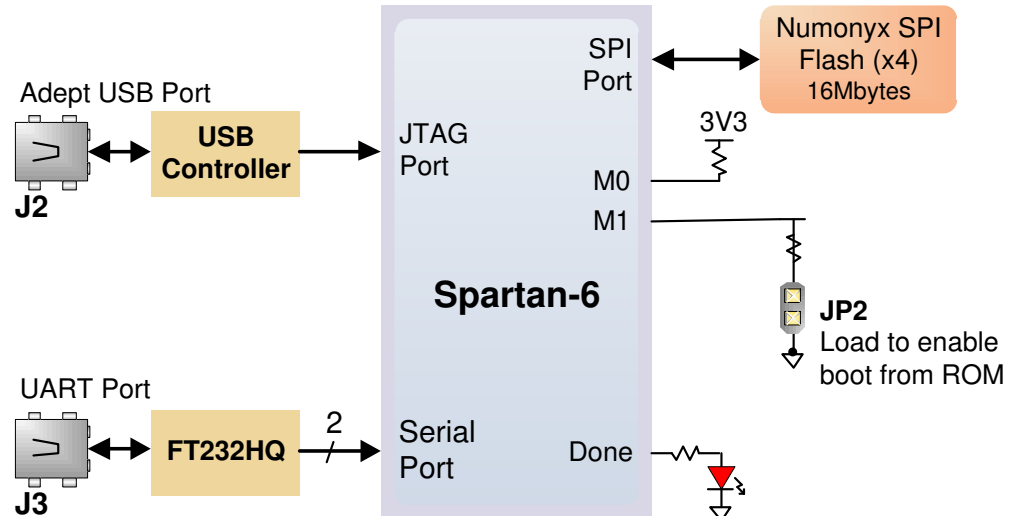

An on-board mode jumper (JP2) selects between JTAG/USB and ROM programming modes. If JP2 is loaded, the FPGA will automatically configure itself from the ROM. If JP2 is not loaded, the FPGA will remain idle after power-on until configured from the JTAG port.

Both Digilent and Xilinx freely distribute software that can be used to program the FPGA and the SPI ROM. Programming files are stored within the FPGA in SRAM-based memory cells. This data defines the FPGA's logic functions and circuit connections, and it remains valid until it is erased by removing power or asserting the PROG\_B input, or until it is overwritten by a new configuration file.

FPGA configuration files transferred via the JTAG port use the .bit or .svf file types. Xilinx's ISE WebPack and EDK software can create .bit, .svf, .bin, or .mcs files from VHDL, Verilog, or schematic-based source files (EDK is used for MicroBlaze™ embedded processor-based designs).

## Adept and iMPACT USB Port

The Adept port is compatible with Xilinx's iMPACT programming software if the Digilent Plug-In for Xilinx Tools is installed on the host PC (download it free from the Digilent website's software section). The plug-in automatically translates iMPACT-generated JTAG commands into formats compatible with the Digilent USB port, providing a seamless programming experience without leaving the Xilinx tool environment. Once the plug-in is installed, the "third party" programming option can be selected from the iMPACT tools menu, and iMPACT will work as if a Xilinx programming cable were being used. All Xilinx tools (iMPACT, ChipScope, EDK, etc.) can work with the plug-in, and they can be used in conjunction with Adept tools.

Adept's high-speed USB2 system can be used to program the FPGA and ROM and exchange register-based and file-based data with the FPGA. The Adept application, an SDK, and reference materials are freely downloadable from the Digilent website.

## Power Supplies

The FMC Carrier - S6 board requires an external 12V, 5A or greater power source with a coax center-positive 2.1mm internal-diameter plug (a suitable supply is provided as a part of the FMC Carrier - S6 kit). Voltage regulator circuits from Analog Devices create the required 3.3V, 1.8V, 1.23V and VADJ supplies from the main 12V supply. The table below provides additional information, typical currents depend strongly on FGPA configuration, and the values provided are typical of medium-size/speed designs).

FMC Carrier - S6 Power Supplies			
Supply	Circuits	Device	Amps (max)
12V	FMC VCC12V0	IC15: ADP1850	5A
3.3V	FPGA I/O, USB ports, clocks, ROM	IC15: ADP1850	4A
1.8V	FPGA aux, GPIO	IC15: ADP1850	1A
1.23V	FPGA core	IC23: LTC3546	3A
VADJ	1V2, 1V8, 2V5, 3V3	IC23: LTC3413	4.2A

A power-good LED (LD3), driven by the wired-OR of all the power-good outputs on the supplies, indicates that all supplies are operating within 10% of nominal.

The VADJ rail has to be enabled by logic implemented in the FPGA. To do this, set the SET\_VADJ0 and SET\_VADJ1 pins to indicate the desired voltage and drive VADJ\_EN high. It is important to note that FPGA banks 0 and 1 are unpowered whenever VADJ\_EN is low. The table below outlines the different voltages that may be selected:

FMC Carrier - S6 VADJ Levels		
SET_VADJ1	SET_VADJ0	VADJ Voltage
0	0	1.2V
0	1	1.8V
1	0	2.5V
1	1	3.3V

## DDR2 Memory

A single 1Gbit DDR2 memory chip is driven from the memory controller block in the Spartan-6 FPGA. The DDR2 device, a Micron MT47H64M16-25E or equivalent, provides a 16-bit bus and 64M locations. The FMC Carrier - S6 board has been tested for DDR2 operation at up to an 800MHz data rate.

The DDR2 interface follows the pinout and routing guidelines specified in the *Xilinx Memory Interface Generator (MIG) User Guide*. The interface supports SSTL18 signaling, and all address, data, clocks, and control signals are delay-matched and impedance-controlled. Address and control signals are not terminated. Two well-matched DDR2 clock signal pairs are provided so the DDR can be driven with low-skew clocks from the FPGA.

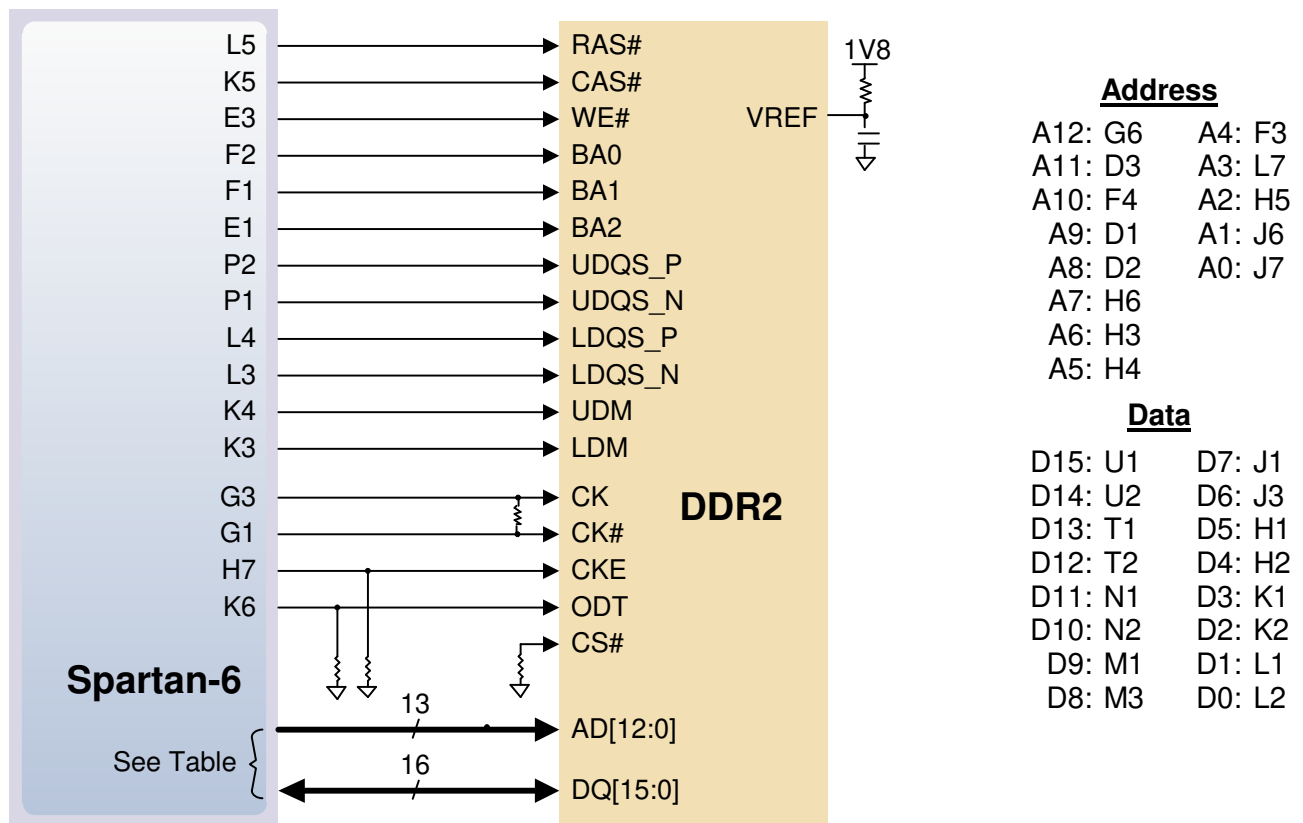

## Flash Memory

The FMC Carrier - S6 board uses a 128Mbit Numonyx N25Q128 Serial Flash memory device (organized as 16-bit by 16Mbytes) for non-volatile storage of FPGA configuration files. The SPI Flash can be programmed with a .bit, .bin., or .mcs file using the Adept software. An FPGA configuration file requires less than 12Mbits, leaving 116Mbits available for user data. Data can be transferred from a PC to/from the Flash by user applications, or by facilities built into the Adept software. User designs programmed into the FPGA can also transfer data to and from the ROM.

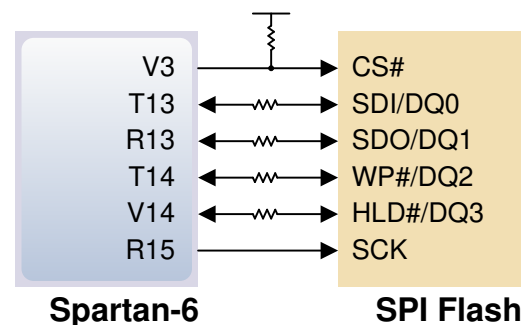

A simple demo image has been loaded into the Serial Flash during manufacturing. It connects the User LEDs (LD0, LD1) to the User Switches (SW0, SW1). The image along with the project source is available on the Digilent website.

## Oscillators/Clocks

The FMC Carrier - S6 board includes a single 100MHz Oscillator connected to pin T9 (T9 is a GCLK input in bank 2). The input clock can drive any or all of the four clock management tiles in the Spartan-6. Each tile includes two Digital Clock Managers (DCMs) and one Phase-Locked Loop (PLL).

DCMs provide the four phases of the input frequency (0°, 90°, 180°, and 270°), a divided clock that can be the input clock divided by any integer from 2 to 16 or 1.5, 2.5, 3.5... 7.5, and two antiphase clock outputs that can be multiplied by any integer from 2 to 32 and simultaneously divided by any integer from 1 to 32.

PLLs use Voltage Controlled Oscillators (VCOs) that can be programmed to generate frequencies in the 400MHz to 1080MHz range by setting three sets of programmable dividers during FPGA configuration. VCO outputs have eight equally-spaced outputs (0°, 45°, 90°, 135°, 180°, 225°, 270°, and 315°) that can be divided by any integer between 1 and 128.

## USB-UART Bridge (Serial Port)

The FMC Carrier - S6 includes an FTDI USB-UART bridge to allow PC applications to communicate with the board using a COM port. Free drivers allow COM-based (i.e., serial port) traffic on the PC to be seamlessly transferred to the FMC

Carrier – S6 board using the USB port at J3 marked UART. The FTDI part delivers the data to the Spartan-6 using a two-wire serial port with software flow control (XON/XOFF). Free Windows and Linux drivers can be downloaded from

[www.ftdichip.com](http://www.ftdichip.com). After the drivers are installed, I/O commands from the PC directed to the COM port will produce serial data traffic on the T10 and Q10 FPGA pins.

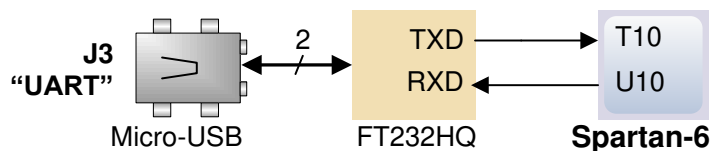

## Basic I/O

The FMC Carrier - S6 board includes two pushbuttons, two slide switches, and two LEDs for basic digital input and output. The buttons and slide switches are connected to the FPGA via series resistors to prevent damage from inadvertent short circuits. The high efficiency LED anodes are connected to the FPGA via 390-ohm resistors, and they will brightly illuminate with about 1mA of current when a logic high voltage is applied to their respective I/O pin.

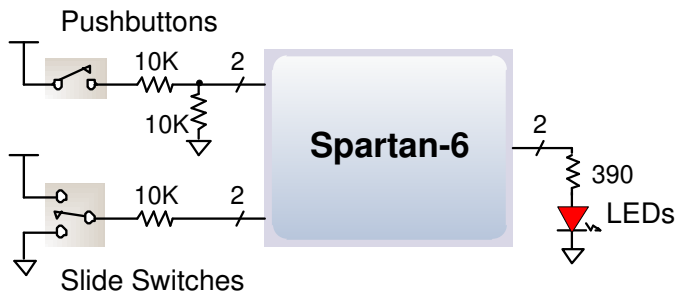

<u>Pushbuttons</u>	<u>Slide Switches</u>	<u>LEDs</u>
BTNU: E4	SW0: U7	LD0: V15
BTND: F5	SW1: V7	LD1: N12

## FMC-HPC Connector

A single high-pin count (HPC) FMC slot is provided on the FMC Carrier – S6 to support a large ecosystem of plug-in modules. The FMC exposes 126 single-ended I/O, 102 of which can be configured as 51 differential pairs. The FMC interface spans over 4 PL I/O banks (banks 0, 1, 2, and Misc.). The FMC pin-out can be found in the FMC Carrier – S6 General UCF file.

## Quality Assurance

All FMC Carrier - S6 boards are 100% tested during the manufacturing process. If any device on the FMC Carrier - S6 board fails test or is not responding properly, it is likely that damage occurred during transport or during use. Typical damage includes stressed solder joints and contaminants in switches and buttons resulting in intermittent failures. Stressed solder joints can be repaired by reheating and reflowing solder and contaminants can be cleaned with off-the-shelf electronics cleaning products. If a board fails test within the warranty period, it will be replaced at no cost. If a board fails test outside of the warranty period and cannot be easily repaired, Digilent can repair the board or offer a discounted replacement. Contact Digilent for more details.

## Appendix 1: Analog Devices Components

ADG3308 – Low Voltage, 8-channel Bidirectional Logic Level Translators

<http://www.analog.com/ADP3308>

ADG719 – CMOS MUX/SPDT Switch

<http://www.analog.com/ADG719>

ADP1850 – Dual DC-to-DC Synch Buck Controller

<http://www.analog.com/ADP1850>

ADG804 – Low Voltage 4V, 4-Channel Multiplexer

<http://www.analog.com/ADG804>