



Chipsmall Limited consists of a professional team with an average of over 10 year of expertise in the distribution of electronic components. Based in Hongkong, we have already established firm and mutual-benefit business relationships with customers from,Europe,America and south Asia,supplying obsolete and hard-to-find components to meet their specific needs.

With the principle of “Quality Parts,Customers Priority,Honest Operation,and Considerate Service”,our business mainly focus on the distribution of electronic components. Line cards we deal with include Microchip,ALPS,ROHM,Xilinx,Pulse,ON,Everlight and Freescale. Main products comprise IC,Modules,Potentiometer,IC Socket,Relay,Connector.Our parts cover such applications as commercial,industrial, and automotives areas.

We are looking forward to setting up business relationship with you and hope to provide you with the best service and solution. Let us make a better world for our industry!



Contact us

Tel: +86-755-8981 8866 Fax: +86-755-8427 6832

Email & Skype: info@chipsmall.com Web: www.chipsmall.com

Address: A1208, Overseas Decoration Building, #122 Zhenhua RD., Futian, Shenzhen, China



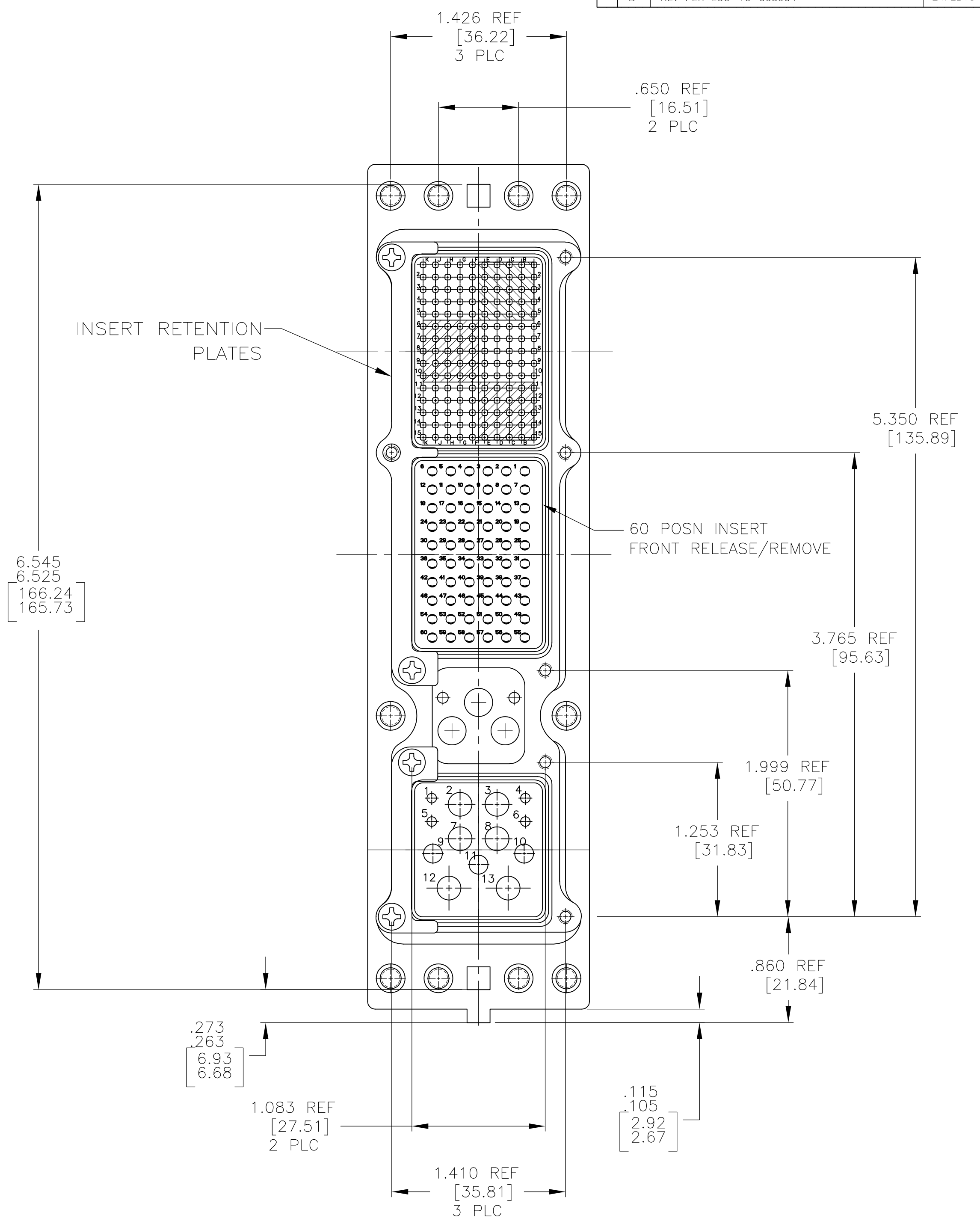
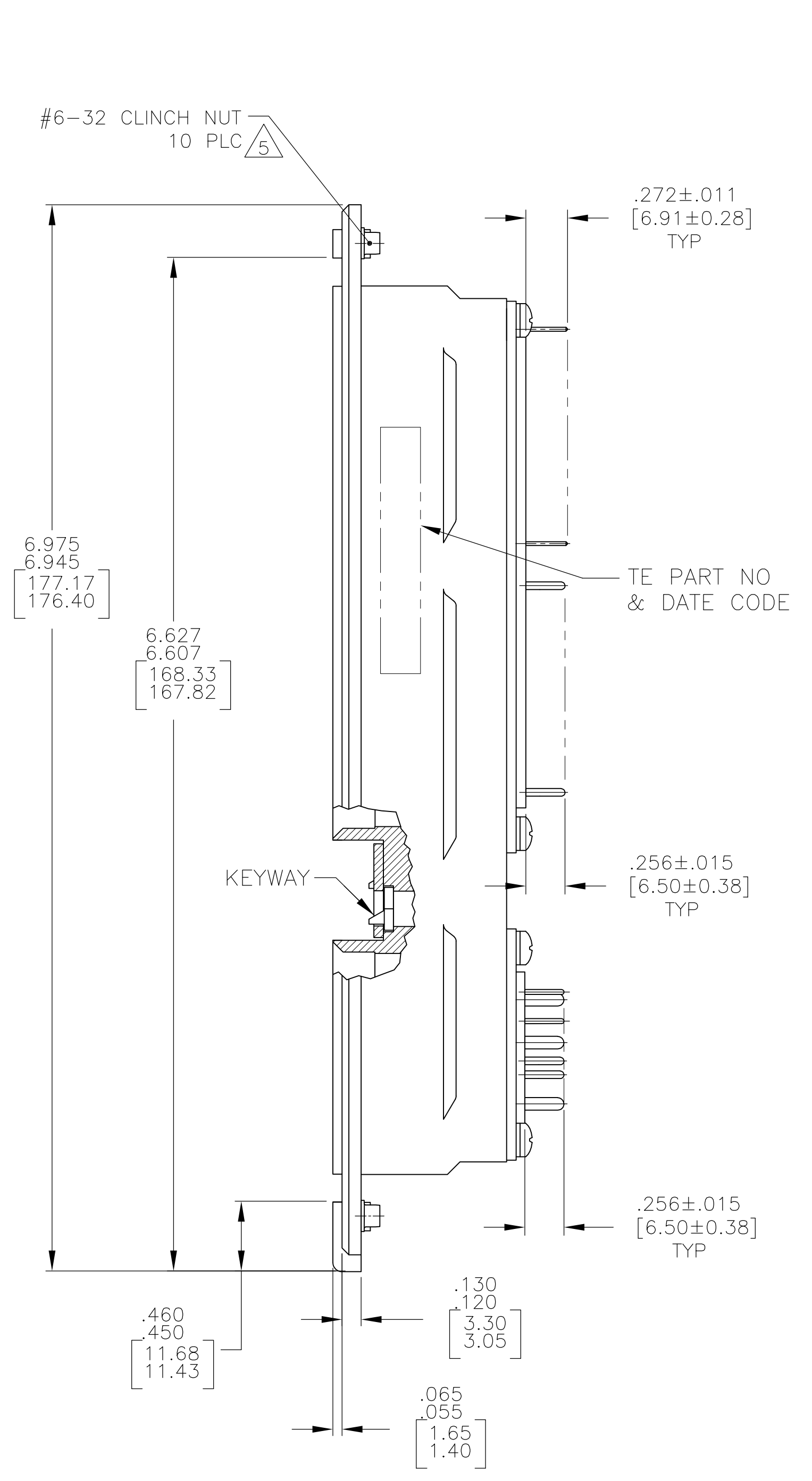
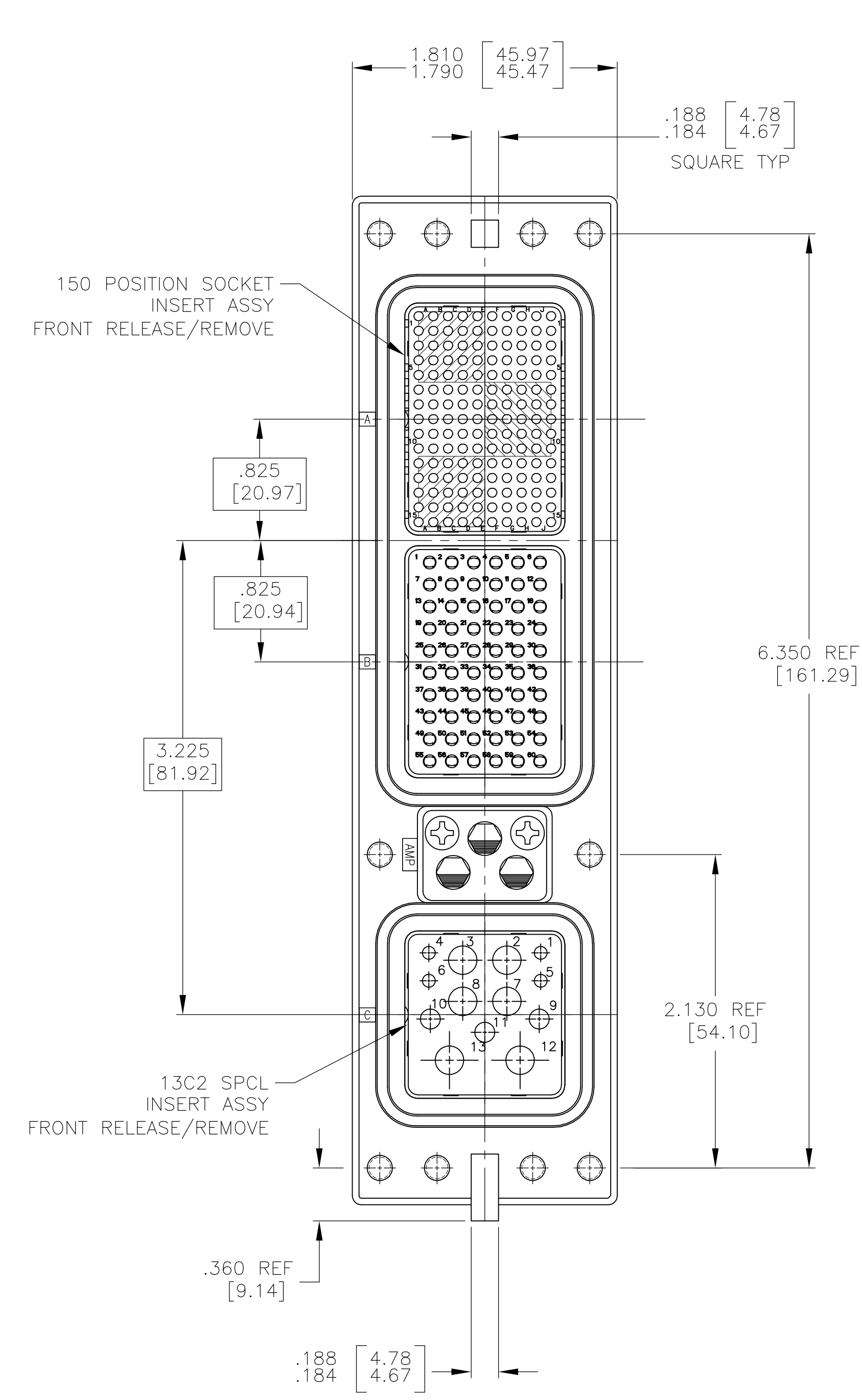

2101457-1 SHOWN

- CONNECTOR DIMENSIONS ARE PER ARINC 600 SPECIFICATION.
 - CONNECTOR IS SUPPLIED WITH A DUST COVER INSTALLED; NOT SHOWN.
 - KEYING SHOWN IN POSITION "01" FOR ILLUSTRATION ONLY. CONNECTORS SHIPPED WITH KEYING INSTALLED IN POSITION PER TABLE. FOR POSITION "00" KEYING HARDWARE SHIPPED UNASSEMBLED.
 - CONTACTS NOT SHOWN IN FRONT & REAR VIEWS FOR CLARITY.
- 5 STEEL CLINCH NUTS ELLIPTICALLY DEFORMED COATED WITH A DRY MOLY LUBE FILM.
- 6 CONTACTS INSTALLED IN SHADED AREAS PER SHEET 2
- 7 ALL CONTACTS INSTALLED.

COMPONENT	MATERIAL	FINISH
SHELL	DIE CAST ALUMINUM PER ASTM-B-85	ELECTROLESS NICKEL PER MIL-C-26074
INSERT RETENTION PLATES	ALUMINUM ALLOY PER ASTM-B-209	CHROMATE PER MIL-DTL-5541
SCREWS AND LOCKWASHERS	STEEL OR STAINLESS STEEL	CHROMATE OVER ZINC PASSIVATED
POLARIZING KEYS	ZINC ALLOY PER ASTM-B-86	-
POLARIZING KEY RETAINING PLATE	ALUMINUM ALLOY PER ASTM-B-209	BLUE ANODIZED PER MIL-A-8625
INSERTS	THERMOSET OR THERMOPLASTIC PPS PER MIL-M-24519	-

KEYING POSITION	CONTACTS INCLUDED	PART NUMBER
"00"	MODULE A 211431-4 (SZ 22 SOCKET CONTACT; QTY=89) MODULE B 1-448138-2 (SZ 20 POSTED PIN CONTACT; QTY=34) MODULE C 1-448140-8 (SZ 12 POSTED PIN CONTACT; QTY=5) 1-448139-4 (SZ 16 POSTED PIN CONTACT; QTY=3)	6 2101457-2
"00"	MODULE A 211431-4 (SZ 22 SOCKET CONTACT; QTY=150) MODULE B 1-448138-2 (SZ 20 POSTED PIN CONTACT; QTY=60) MODULE C 1-448140-8 (SZ 12 POSTED PIN CONTACT; QTY=6) 1-448139-4 (SZ 16 POSTED PIN CONTACT; QTY=3) 1-448138-2 (SZ 20 POSTED PIN CONTACT; QTY=4)	7 2101457-1

THIS DRAWING IS A CONTROLLED DOCUMENT.

DIMENSIONS: INCHES [mm]

TOLERANCES UNLESS OTHERWISE SPECIFIED:

0 PLC	± .005
1 PLC	± .004
2 PLC	± .003
3 PLC	± .002
4 PLC	± .001
ANGLES	± .001

MATERIAL SEE TABLE FINISH SEE TABLE

THIS DRAWING IS A CONTROLLED DOCUMENT. DWN C.C.THOMAS 6-23-09 CHK K.THACKSTON 6-23-09 APVD K.THACKSTON 6-23-09 NAME RCPT ASSY, SIZE 2, ARINC 600 (150/60/13C2 SPCL) PRODUCT SPEC APPLICATION SPEC WEIGHT -- SIZE A1 CAGE CODE 00779 DRAWING NO. 2101457 RESTRICTED TO CUSTOMER DRAWING SCALE 3:2 SHEET 1 OF 2 REV B

Tyco Electronics Corporation Harrisburg, Pa 17105-3608

LOC		DIST		REVISIONS			
P	LTR	DESCRIPTION	DATE	DNW	APVD		
-	-	SEE SHEET 1	-	-	-	-	-

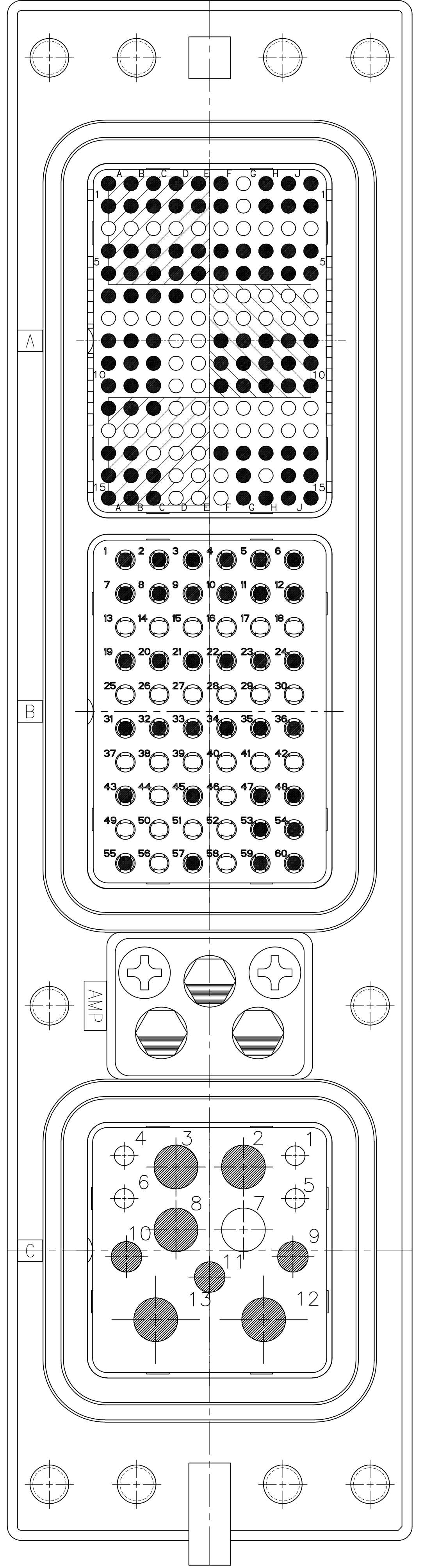

2101457-2 SHOWN

THIS DRAWING IS A CONTROLLED DOCUMENT.		DNW C.C.THOMAS 6-23-09	Tyco Electronics Corporation Harrisburg, Pa 17105-3608	
DIMENSIONS: INCHES [mm]		CHK K.THACKSTON 6-23-09	NAME RCPT ASSY, SIZE 2, ARINC 600 (150/60/13C2 SPCL)	
TOLERANCES UNLESS OTHERWISE SPECIFIED:		APVD K.THACKSTON 6-23-09	RESTRICTED TO	
0. PLC ± -		PRODUCT SPEC		
1. PLC ± -		APPLICATION SPEC		
2. PLC ± -		SIZE CAGE CODE DRAWING NO		
3. PLC ± -		A1 00779 C=2101457		
4. PLC ± -		WEIGHT		
ANGLES ± -		CUSTOMER DRAWING		
MATERIAL SEE TABLE		FINISH SEE TABLE		SCALE 3:2 SHEET 2 OF 2 REV B