



Chipsmall Limited consists of a professional team with an average of over 10 year of expertise in the distribution of electronic components. Based in Hongkong, we have already established firm and mutual-benefit business relationships with customers from,Europe,America and south Asia,supplying obsolete and hard-to-find components to meet their specific needs.

With the principle of “Quality Parts,Customers Priority,Honest Operation,and Considerate Service”,our business mainly focus on the distribution of electronic components. Line cards we deal with include Microchip,ALPS,ROHM,Xilinx,Pulse,ON,Everlight and Freescale. Main products comprise IC,Modules,Potentiometer,IC Socket,Relay,Connector.Our parts cover such applications as commercial,industrial, and automotives areas.

We are looking forward to setting up business relationship with you and hope to provide you with the best service and solution. Let us make a better world for our industry!



## Contact us

Tel: +86-755-8981 8866 Fax: +86-755-8427 6832

Email & Skype: info@chipsmall.com Web: www.chipsmall.com

Address: A1208, Overseas Decoration Building, #122 Zhenhua RD., Futian, Shenzhen, China



1                      2                      3                      4                      5                      6

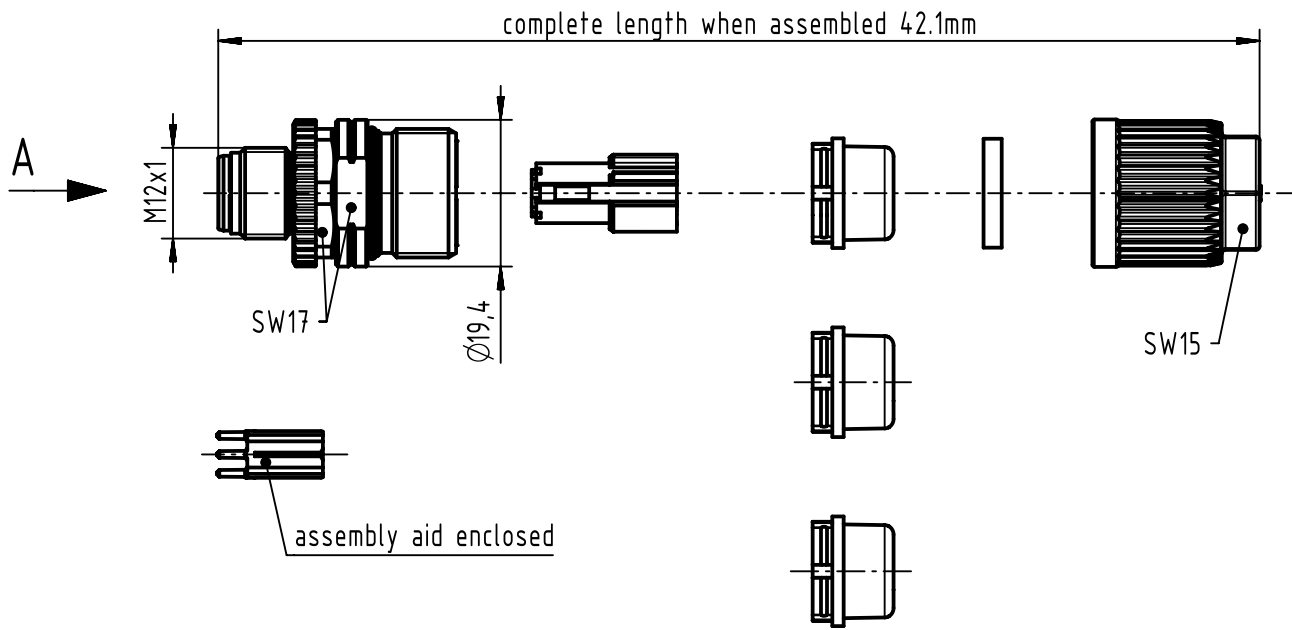

A (2:1)

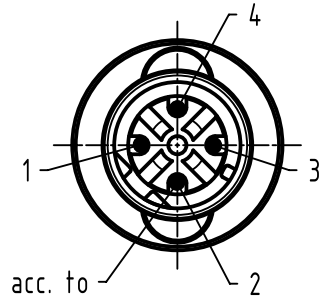

contact face acc. to IEC 61076-2-101

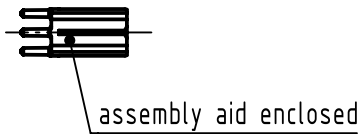

voltage	250V a.c/d.c
current	4A/40°C
working temperature	-40°C - +85°C

order contacts separately

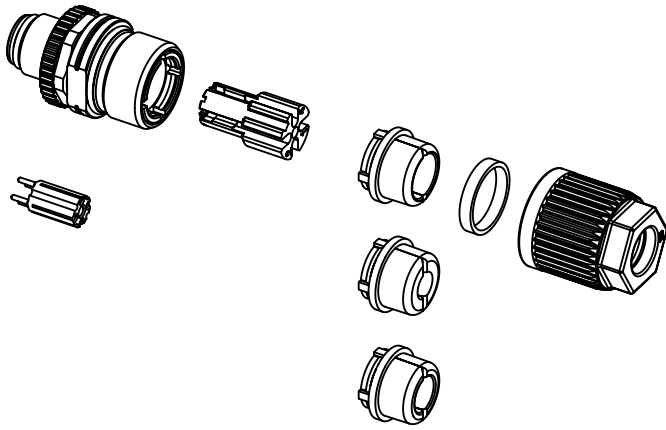

cableø			wire gauge	part-no.
5.5-7.2mm	4.5-5.4mm	7.0-8.8mm		
sealing			AWG 26-22	09670005576
black	transparent	beige	AWG 24-20	09670008576
			AWG 22-18	09670003576

	All Dimensions in mm Original Size DIN A4		Scale 1:1	Free size tol.		Ref. Sub. TB21038822405 / 500000055781 / 09.10.2012	
	All rights reserved Department EC PD - DE		Created by EISFELD	Inspected by WELLMANN	Standardisation HOFFMANN	Date 2015-07-14	State Final Release
HARTING Electronics GmbH D-32339 Espelkamp			Title HARTING M12 crimp male D-coded 4-pole			Doc-Key / ECM-Nr. 100225462/UGD/002/H 500000090521	
			Type TB	Number 21038821405		Rev. H	Page 1/1