



Chipsmall Limited consists of a professional team with an average of over 10 year of expertise in the distribution of electronic components. Based in Hongkong, we have already established firm and mutual-benefit business relationships with customers from,Europe,America and south Asia,supplying obsolete and hard-to-find components to meet their specific needs.

With the principle of “Quality Parts,Customers Priority,Honest Operation,and Considerate Service”,our business mainly focus on the distribution of electronic components. Line cards we deal with include Microchip,ALPS,ROHM,Xilinx,Pulse,ON,Everlight and Freescale. Main products comprise IC,Modules,Potentiometer,IC Socket,Relay,Connector.Our parts cover such applications as commercial,industrial, and automotives areas.

We are looking forward to setting up business relationship with you and hope to provide you with the best service and solution. Let us make a better world for our industry!



Contact us

Tel: +86-755-8981 8866 Fax: +86-755-8427 6832

Email & Skype: info@chipsmall.com Web: www.chipsmall.com

Address: A1208, Overseas Decoration Building, #122 Zhenhua RD., Futian, Shenzhen, China



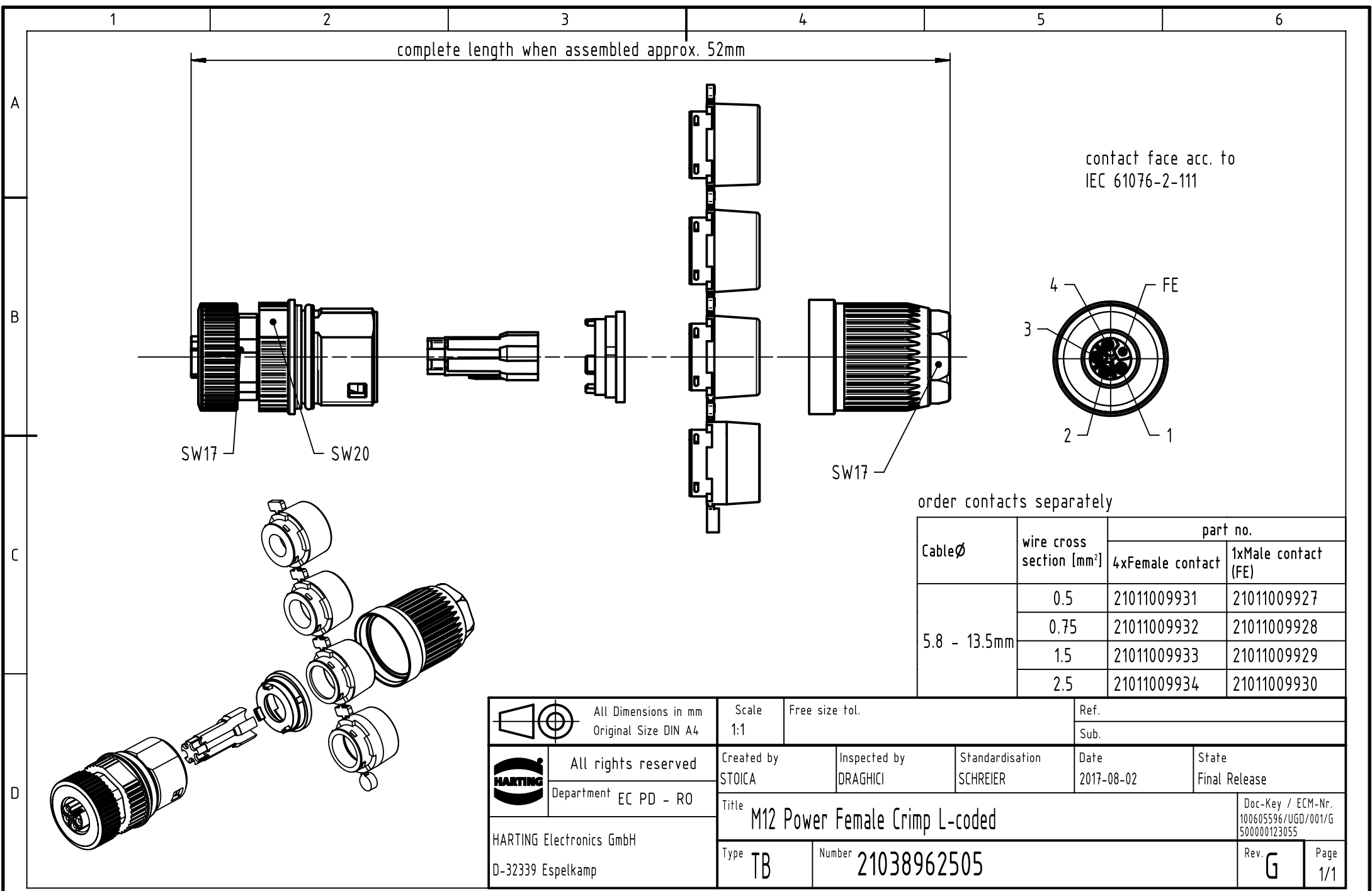

complete length when assembled approx. 52mm

contact face acc. to IEC 61076-2-111

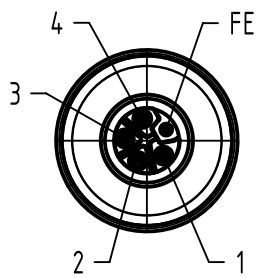

order contacts separately

CableØ	wire cross section [mm²]	part no.	
		4xFemale contact	1xMale contact (FE)
5.8 - 13.5mm	0.5	21011009931	21011009927
	0.75	21011009932	21011009928
	1.5	21011009933	21011009929
	2.5	21011009934	21011009930

All Dimensions in mm Original Size DIN A4		Scale 1:1	Free size tol.		Ref.
All rights reserved Department EC PD - RO		Created by STOICA	Inspected by DRAGHICI	Standardisation SCHREIER	Date 2017-08-02
HARTING Electronics GmbH D-32339 Espelkamp		Title M12 Power Female Crimp L-coded			State Final Release
		Type TB	Number 21038962505		Doc-Key / ECM-Nr. 100605596/UGD/001/G 500000123055
				Rev. G	Page 1/1