



Chipsmall Limited consists of a professional team with an average of over 10 year of expertise in the distribution of electronic components. Based in Hongkong, we have already established firm and mutual-benefit business relationships with customers from,Europe,America and south Asia,supplying obsolete and hard-to-find components to meet their specific needs.

With the principle of "Quality Parts,Customers Priority,Honest Operation,and Considerate Service",our business mainly focus on the distribution of electronic components. Line cards we deal with include Microchip,ALPS,ROHM,Xilinx,Pulse,ON,Everlight and Freescale. Main products comprise IC,Modules,Potentiometer,IC Socket,Relay,Connector.Our parts cover such applications as commercial,industrial, and automotives areas.

We are looking forward to setting up business relationship with you and hope to provide you with the best service and solution. Let us make a better world for our industry!



## Contact us

Tel: +86-755-8981 8866 Fax: +86-755-8427 6832

Email & Skype: info@chipsmall.com Web: www.chipsmall.com

Address: A1208, Overseas Decoration Building, #122 Zhenhua RD., Futian, Shenzhen, China



LOC		DIST		REVISIONS			
DF	DO	REV	DATE	BY	CHK	APPV	
G		1	24DEC10	SK	RL		

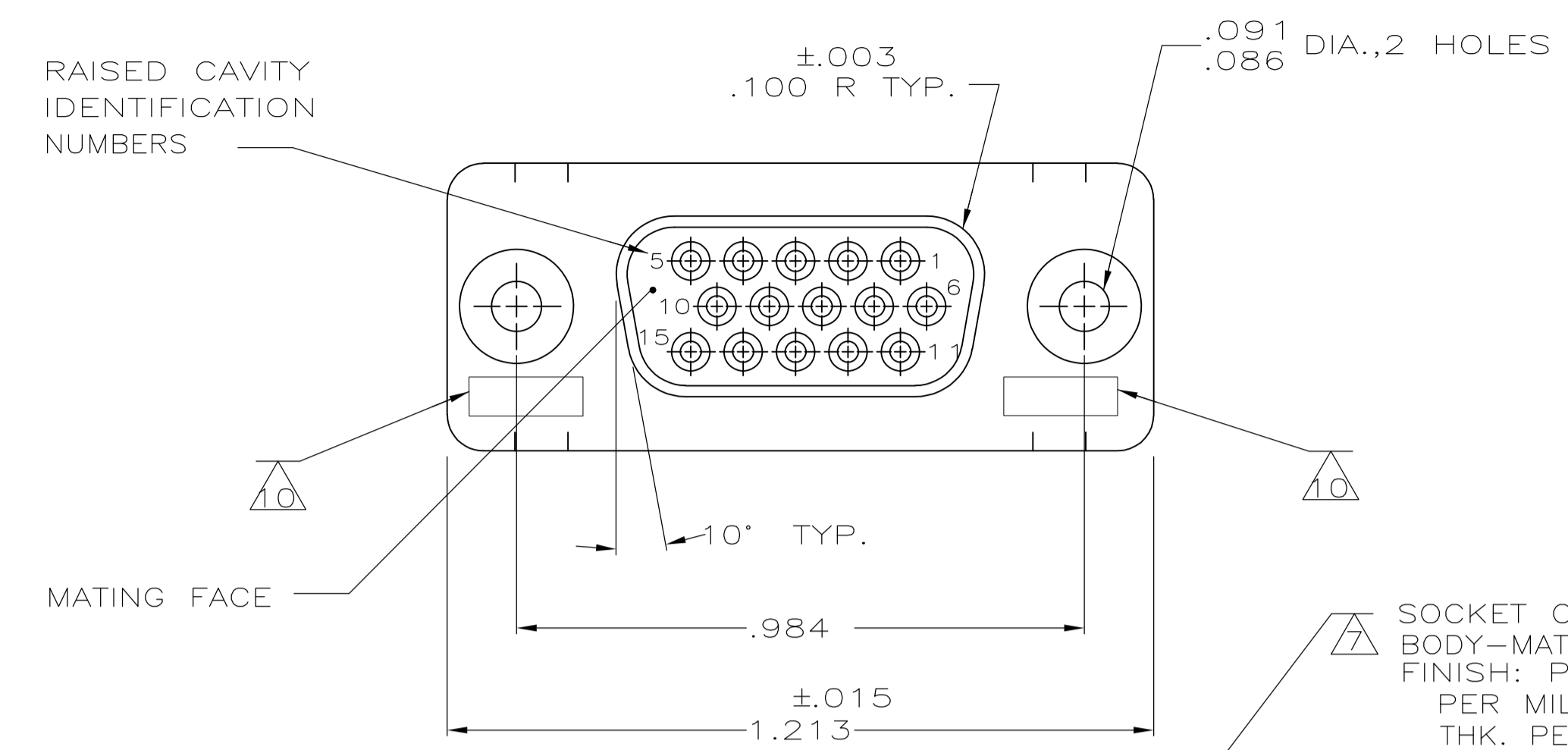

SOCKET CONTACT, SIZE 22, 15 REQD.  
 BODY-MATL: BERYLLIUM COPPER PER QQ-C-530  
 FINISH: PLATED GOLD .000050 MIN. THK.  
 PER MIL-G-45204 OVER NICKEL .000050 MIN.  
 THK. PER QQ-N-290  
 HOOD-MAT'L: STAINLESS STEEL PER QQ-S-766  
 FINISH: PASSIVATED PER QQ-P-35B

AMP & DATE CODE INK STAMPED,  
 NEAR SIDE; M24308 INK STAMPED FAR SIDE

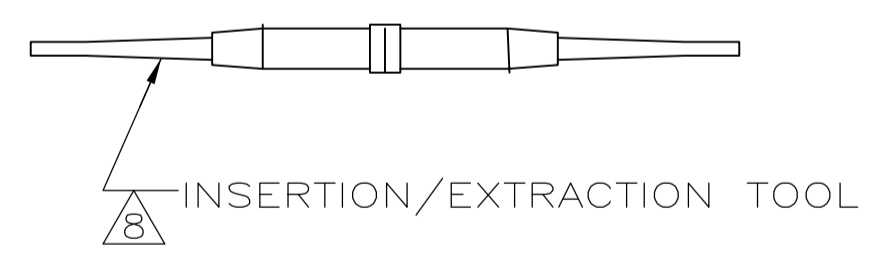
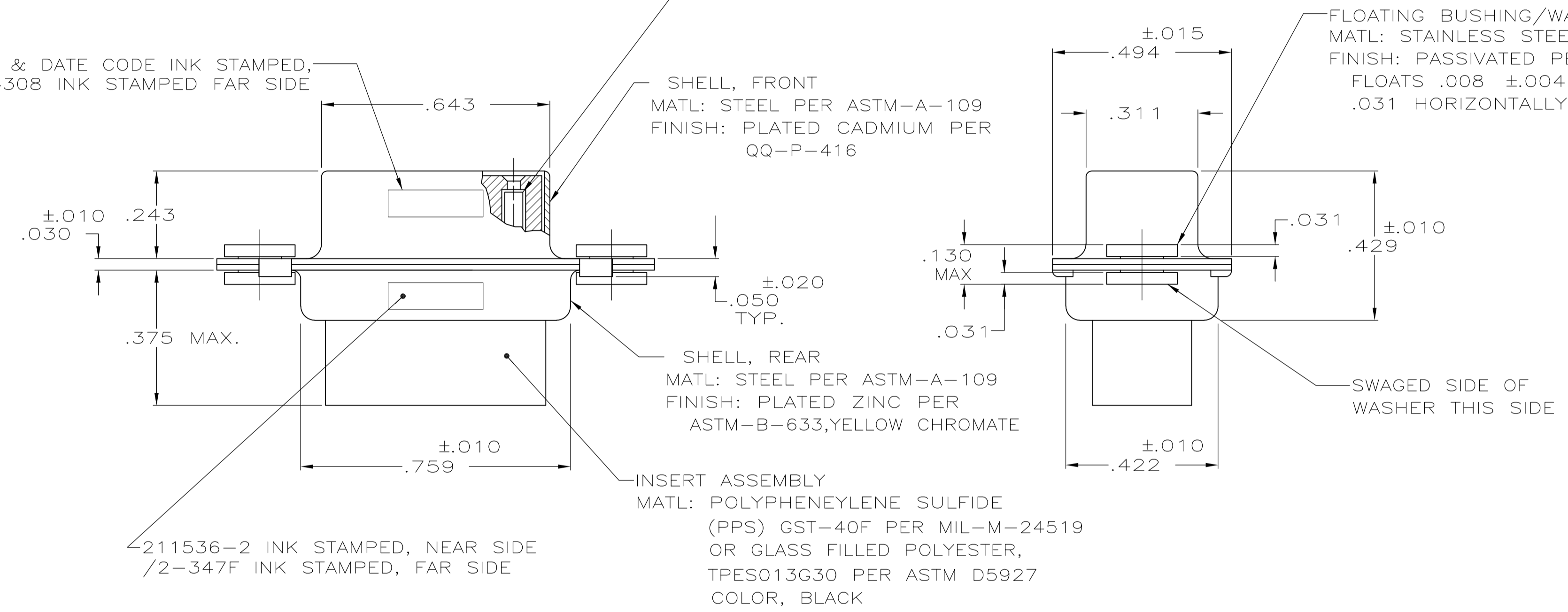

- THIS RECEPTACLE WILL MATE WITH ANY 15 POSN., SIZE 1 PLUG IN AMPLIMITE SERIES.
- MAXIMUM WIRE INSULATION TO BE USED WITH THIS RECEPTACLE IS .054 DIA.
- SST RETENTION CLIPS ARE INCLUDED IN INSERTS.
- PACKAGE STAMPED M24308/2-487F & AMP P/N 211536-1
- PACKAGE STAMPED M24308/2-347F & AMP P/N 211536-2
- PACKAGE STAMPED M24308/2-358F & AMP P/N 211536-3
- AMP P/N 204351-1; MIL P/N 57-354, INCLUDED IN KIT
- AMP P/N 91067-1; MIL P/N M81969/1-04
- CONNECTOR SUPPLIED WITHOUT CONTACTS; SHOWN FOR ILLUSTRATION ONLY.
- UL/CSA DESIGNATION STAMPED IN THIS AREA.

DESCRIPTION	PART NO
SUPSD BY 204536-2 & 91067-1	211536-3
SAME AS -1 EXCEPT: 6, 7, 8	211536-2
AS SHOWN	211536-1

THIS DRAWING IS A CONTROLLED DOCUMENT.		D.D. ERDMAN 06-21-85		Tyco Electronics Corporation	
DIMENSIONS: INCHES		R. GRZYBOWSKI 09-20-85		Harrisburg, PA 17105-3608	
TOLERANCES UNLESS OTHERWISE SPECIFIED:		G. SACUNAS 09-20-85		NAME	
0. PLC ± -		PRODUCT SPEC		RECEPTACLE ASSEMBLY, AMPLIMITE	
1. PLC ± -		APPLICATION SPEC		15 POSITION, SIZE 1, SERIES 90	
2. PLC ± -		SIZE		W/DUAL FLOAT BUSHING	
3. PLC ± .005		WEIGHT		RESTRICTED TO	
4. PLC ± -		SCALE		A1 00779 C=211536	
ANGLES ± ° 30'		SHEET		1 OF 1	
MATERIAL SEE CALLOUT		FINISH SEE CALLOUT		CUSTOMER DRAWING	