



Chipsmall Limited consists of a professional team with an average of over 10 year of expertise in the distribution of electronic components. Based in Hongkong, we have already established firm and mutual-benefit business relationships with customers from,Europe,America and south Asia,supplying obsolete and hard-to-find components to meet their specific needs.

With the principle of “Quality Parts,Customers Priority,Honest Operation,and Considerate Service”,our business mainly focus on the distribution of electronic components. Line cards we deal with include Microchip,ALPS,ROHM,Xilinx,Pulse,ON,Everlight and Freescale. Main products comprise IC,Modules,Potentiometer,IC Socket,Relay,Connector.Our parts cover such applications as commercial,industrial, and automotives areas.

We are looking forward to setting up business relationship with you and hope to provide you with the best service and solution. Let us make a better world for our industry!



Contact us

Tel: +86-755-8981 8866 Fax: +86-755-8427 6832

Email & Skype: info@chipsmall.com Web: www.chipsmall.com

Address: A1208, Overseas Decoration Building, #122 Zhenhua RD., Futian, Shenzhen, China



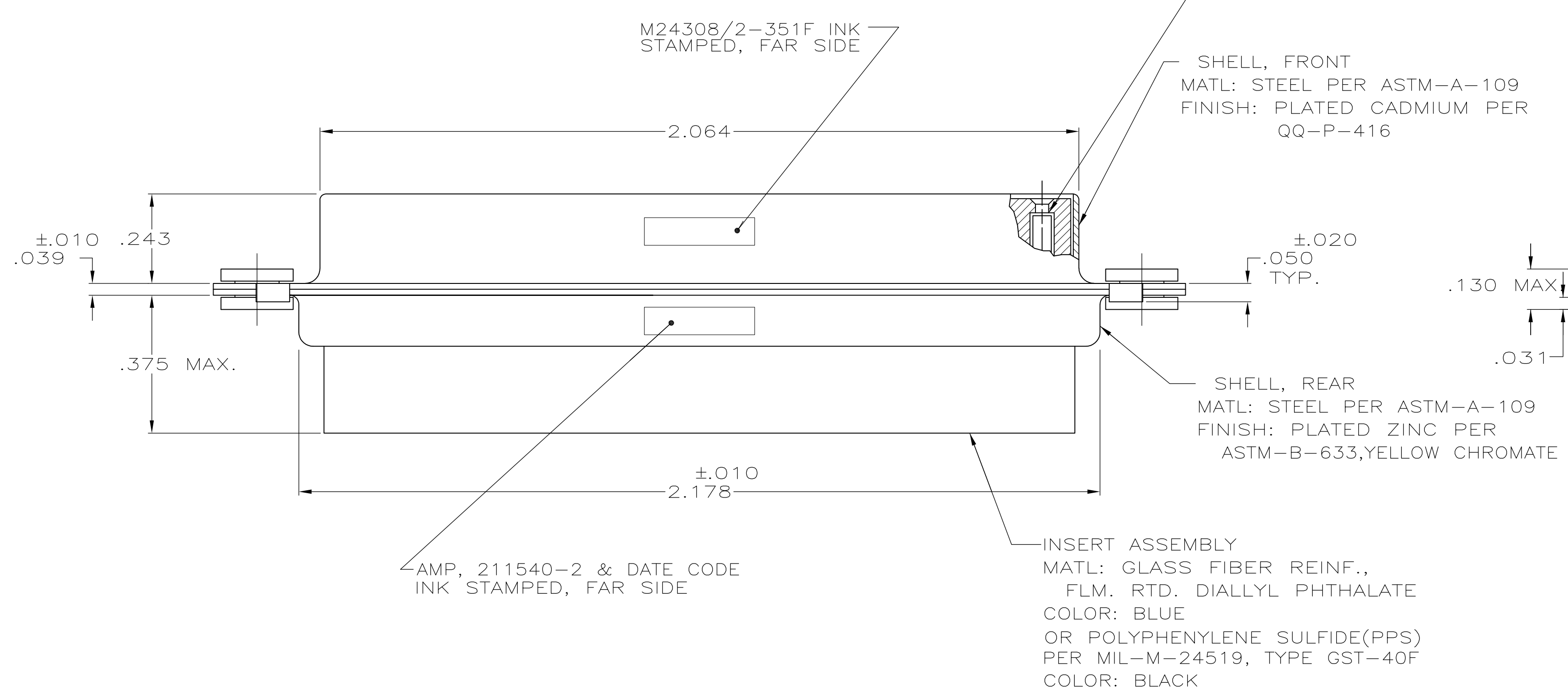
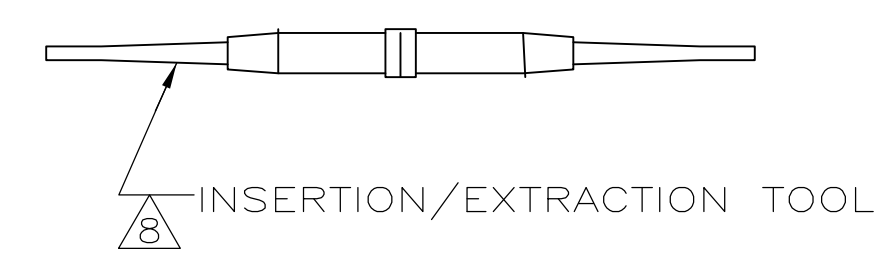
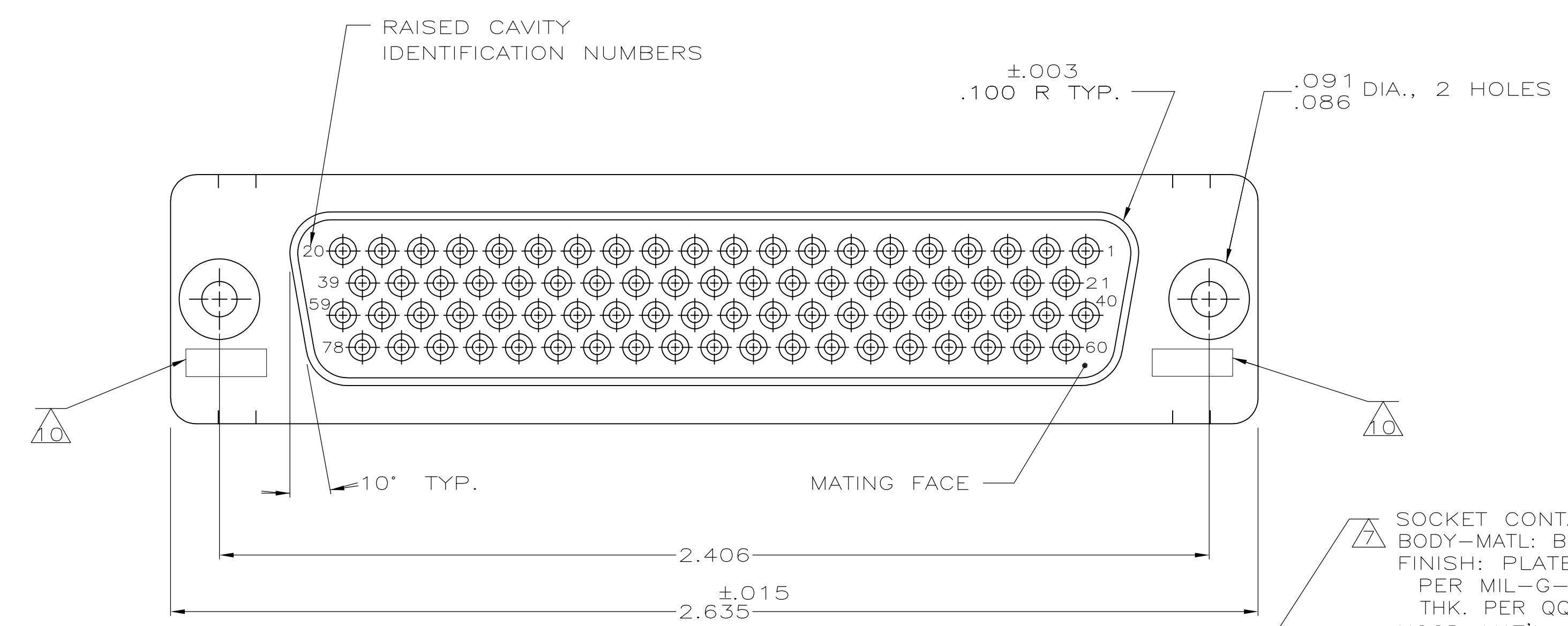

SOCKET CONTACT, SIZE 22, 78 REQD.
 BODY-MATL: BERYLLIUM COPPER PER QQ-C-530
 FINISH: PLATED GOLD .000050 MIN. THK.
 PER MIL-G-45204 OVER NICKEL .000050 MIN.
 THK. PER QQ-N-290
 HOOD-MAT'L: STAINLESS STEEL PER QQ-S-766
 FINISH: PASSIVATED PER QQ-P-35B

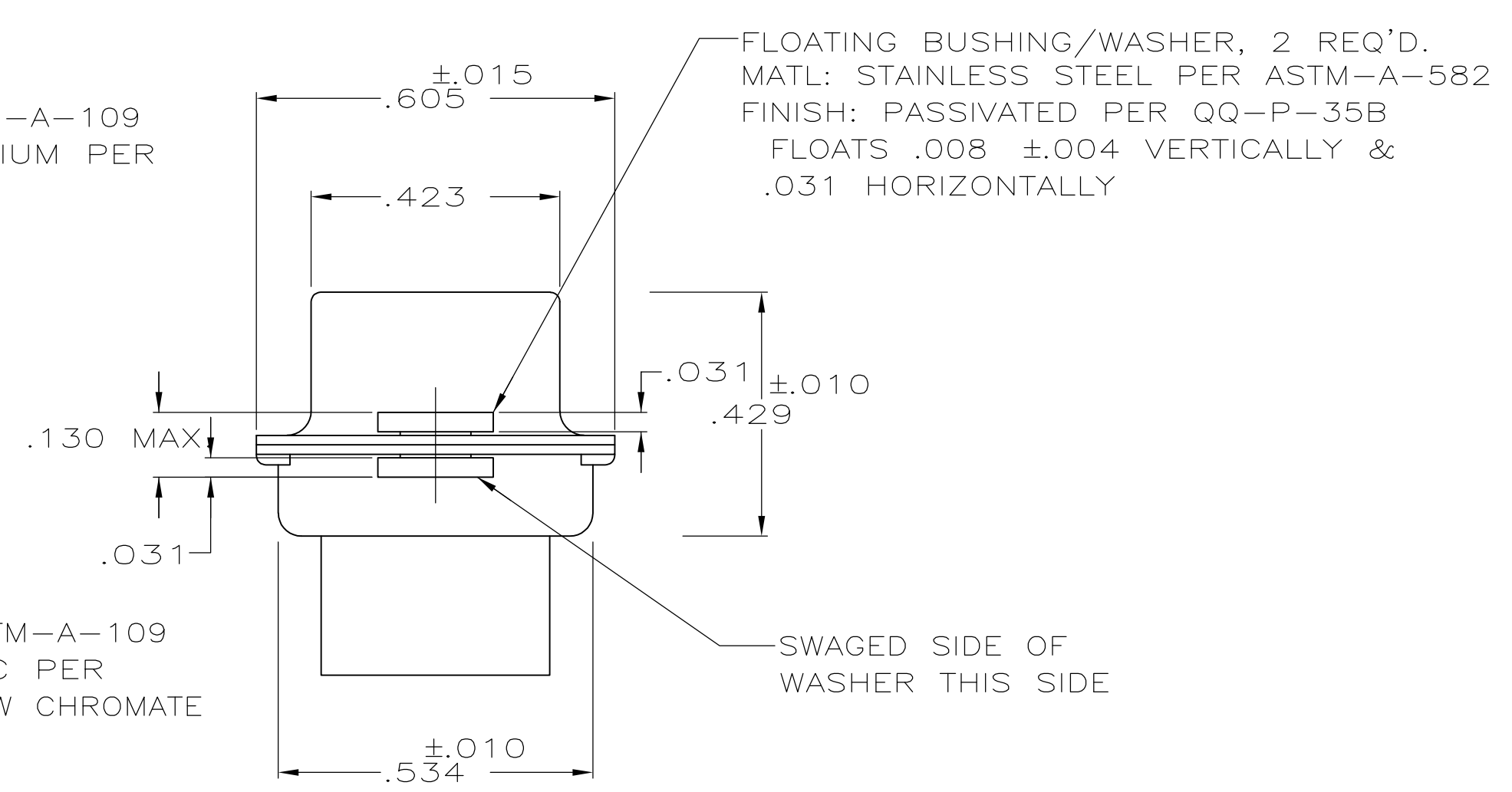

- THIS RECEPTACLE WILL MATE WITH ANY 78 POSN., SIZE 5 PLUG IN AMPLIMITE SERIES.
- MAXIMUM WIRE INSULATION TO BE USED WITH THIS RECEPTACLE IS .054 DIA.
- SST RETENTION CLIPS ARE INCLUDED IN INSERTS.

- ④ PACKAGE STAMPED M24308/2-491F & AMP P/N 211540-1
- ⑤ PACKAGE STAMPED M24308/2-351F & AMP P/N 211540-2
- ⑥ PACKAGE STAMPED M24308/2-362F & AMP P/N 211540-3
- ⑦ AMP P/N 204351-1; MIL P/N 57-354, INCLUDED IN KIT
- ⑧ AMP P/N 91067-1; MIL P/N M81969/1-04
- ⑨ CONNECTOR SUPPLIED WITHOUT CONTACTS; SHOWN FOR ILLUSTRATION ONLY.
- ⑩ UL/CSA DESIGNATION STAMPED IN THIS AREA, OPTIONAL

SUPSD BY 204544-2 & 91067-1	SAME AS -1 EXCEPT: ⑥ ⑦ ⑧	211540-3
	SAME AS -1 EXCEPT: ⑤ ⑦	211540-2
	AS SHOWN ④ ⑨	211540-1

THIS DRAWING IS A CONTROLLED DOCUMENT.		DIN D ERDMAN 7-14-85	Tyco Electronics Corporation Harrisburg, PA 17105-3608	
DIMENSIONS: INCHES		CHK R. GRZYBOWSKI 9-20-85	NAME L. ROPIER	
TOLERANCES UNLESS OTHERWISE SPECIFIED:		APVD	PRODUCT SPEC	
0. PLC ± -		APPLICATION SPEC		
1. PLC ± -		SIZE		
2. PLC ± -		CAGE CODE		
3. PLC ± .005		DRAWING NO.		
4. PLC ± -		RESTRICTED TO		
ANGLES ± -		A1 00779 C=211540		
MATERIAL SEE CALLOUT		CUSTOMER DRAWING		
FINISH SEE CALLOUT		SCALE NTS SHEET 1 OF 1 REV E		